



PAKISTAN STEEL CADET COLLEGE



Sindh Public Procurement Regulatory Authority
Government of Sindh,
Block-8, Sindh Secretariat No. 4-A,
Court road,
Karachi.
Tel +021-99205356

Dear Sir,

Subject: Tender Notice No. PSCC/HWT/GSF-001/Projects/2018

Please find enclosed herewith the original signed copy of our Tender Notice No. PSCC/HWT/GSF-001/Projects/2018 for hosting on your website. The Tender is not being sent to the newspapers, as the estimated cost of the tender is below Rs. 1.0 Million.

With kind regards,

Yours truly,

Principal

Pakistan Steel Cadet College

Dr. Abdul Rehman Jiskani
PRINCIPAL
Pakistan Steel Cadet College
Steel Town, Karachi

Attachment(s) :

- NIT
- Bidding Documents
- Annual Procurement Plan
- Notification for Complaint Redressal Committee

Constitution of Tender Committee

Advance Cheque No. 10932349 dated 05-03-18 Bnak Al-Habib, Gulshan-e-Hadeed Branch, Karachi of Rs. 2000/-.

SPPRA INWARD DIARY

NO : 6653

DATED 05/03/2018

PAKISTAN STEEL CADET COLLEGE

Established in 1982



TENDER NOTICE

PSCC/HWT/GSF-001/Projects/2018



Pakistan Steel Cadet College (PSCC), Steel Town, Karachi invites tenders from civil works contractors registered with Income Tax & Sindh Revenue Board for following construction works as funds approved by the Govt. of Sindh . Tender forms /documents can be obtained from the office of Vice Principal (Admin) through application alongwith pay order @ Rs. 1000/- (non refundable) in favour of "Pakistan Steel Cadet College" for each work up to 26.03.2018 at 9:00 am to 01:00 pm (except Sunday).

S.No.	Description
1.	Work of Proposed 2nd Horse Riding Club & Recreational Facilities.
2.	Proposed Walkway to College Masjid.

Interested parties can be submitted their sealed quotations alongwith payorder of 02% of Total bid value for each work separately as Earnest Money in favour of "Pakistan Steel Cadet College" latest by 10:30 am on 27.03.2018 in the office of Vice Principal (Admin). The tenders will be opened in the same office at 11:00 am on the same day in presence of the bidders or their representatives. The Procuring Agency has reserved the right to reject all or any bid subject to all relevant provision of SPP Rule No. 25.

Responsive bidder is to submit the following documents with bid:

- At least 02 No.s of work order required of similar nature of work alongwith successfully completion certificate of last year.
- Minimum Turnover for a year at least 0.5 (M).

For more details and any information, please contact

Admin Office
Pakistan Steel Cadet College,
Steel Town, Bin Qasim, Karachi.
021-34721935, 34157884, 99264308
Fax: 021-34721945
Email: mypscc7510@yahoo.com

Dr. Abdul Rehman Jiskani
Principal

Dr Abdul Rehman Jiskani
PRINCIPAL
Pakistan Steel Cadet College
Steel Town, Karachi.



PAKISTAN STEEL CADET COLLEGE STEEL TOWN KARACHI

GENERAL TERMS & CONDITIONS

TENDER NO. PSCC/HWT/GSF-01/Projects/2018



PAKISTAN STEEL CADET COLLEGE

GENERAL TERMS CONDITIONS

FOR THE WORK OF PROPOSED 2ND HORSE RIDING CLUB & RECREATIONAL FACILITIES AT
PAKISTAN STEEL CADET COLLEGE (PSCC), STEEL TOWN, KARACHI.

ISSUED TO M/S. _____

1. Sealed offers are invited from reputable / experienced contractors / Firms with the following terms and conditions. Tender documents may be obtained against pay orders of Rs. 1,000/- (Non refundable) drawn in favour of Pakistan Steel Cadet College.
2. The rate(s) must be quoted in words as well as well in figures. Wherever a discrepancy exists between the rate(s) the one written in words shall be taken as correct.
3. Offers received with over writing / cutting, mutilated or doubtful figures will be rejected. Cutting, if at all unavoidable, must be rewritten and must be stamped and signed distinctly. However applying of correcting fluid on the offers is strictly prohibited. In case of violation of these conditions Tender Opening Committee have a right to reject the offer on spot.
4. Conditional tender will not be considered and liable to be rejected by Tender Opening Committee on spot.
5. The rates shall be quoted by the bidders on prescribed BOQs, enclosed herewith. The offers received other than the form of BOQs enclosed shall not be acceptable.
6. Bidders should quote strictly according to tenderer specifications. The alternative / deviated offers shall not be entertained.
7. All columns of tender enquiry / BOQs must be filled in properly and it should be signed and stamped as acceptance of terms and conditions.
8. The validity of tender must be of minimum period of (90)Ninety days from the opening date of tender.
9. Violation of any condition mentioned in tender documents shall be automatically disqualified.
10. The bidders are requested to submit their envelopes containing offers and Earnest Money in separate envelop address to Pakistan Steel Cadet College Steel Town Karachi up to 10:30 am on 27.03.2018. Thereafter tender will be opened on the same day / date at 11:00 am in the presence of Proprietor of the firm or his authorized representative who may like to attend in the college. Bids received after the above deadline shall not be accepted and be returned unopened. Telegraphic / Telex / Fax bids shall be not accepted. The tender documents / BOQs duly signed and stamped must be returned back in original during opening of the tender.
11. The parties / contractors offering their bids against this tender are required to deposit earnest money of 2% (Two percent) of quoted Bid amount in shape of pay order drawn in favour of Pakistan Steel Cadet College. The validity period of earnest money is (30) days following the date set for the opening of tenders by the college. The earnest money of the successful renderers will be retained until the contract is signed.



12. No tender will be considered by TOC unless it is accompanied by the Earnest Money.

13. Retention money shall be deducted by five percent (5%) on each running bill till the aggregate deductions reached 2.5% of the contract value. The contractors would then be allowed to submit irrevocable bank guarantees for the balance of 2.5%. If the bank guarantee is not submitted by the contractor then deduction @ 5% of the contract value will continue. This amount shall be retained till completion period plus (12) months thereafter. (Only for engineering contracts)

14. EVALUATION CRITERIA

- a) During bid evaluation Pakistan Steel Cadet College may, at its discretion ask the bidders for a clarification of the bid. The request for clarification and the response shall be in writing, and no change in the price of substance of the bid shall be sought.
- b) Pakistan Steel Cadet College will examine the bids to determine whether these are complete or any computational error have been furnished, the documents have been properly signed and the bids are generally found in order.
- c) Arithmetical error will be rectified on the following basis. If there is discrepancy between the unit price and the total price, which is obtained by multiplying the unit price and quantity, or between subtotals and the total price, The unit or subtotal price shall prevail and the total price shall be corrected. If there is a discrepancy between words and figures, the amount in words will prevail. If a bidder does not accept the correction of errors, its bid will be rejected.
- d) Pakistan Steel Cadet College may waive any minor informality, non confirmatory or irregularity in a bid that does not constitute a material deviation whether or not identified by the bidder to its bid and shall not prejudice or effect the relative ranking of any bidder as a result of the technical and commercial evaluation.
- e) Pakistan Steel Cadet College will determine whether each bid is of acceptable quality, is complete and is substantially responsive to the bidding documents for this purpose. Substantially responsive bid is one that confirms to all the terms, conditions and specifications of the bidding documents without material deviations, objection. Conditionally or reservation is one:-
 - i) That effect in any substantial way the scope, quality, quantity or performance of the contract.
 - ii) The limits in any substantial way, in consistent with the bidding documents issued by Pakistan Steel Cadet College right or the successful bidders obligations under the contract.
 - iii) Whose rectification would unfairly affect the competitive position of other bidders who are presenting substantially responsive bids.
- f) If a bid is not substantially responsive it will be rejected and may not subsequently be made responsive by the bidder by correction of the non conformity. Determination of a bid's responsive is to be based on the contents of the bid it self without resource to extrinsic evidence.
- g) The bid will be examined and compared with the technical aspects of the bid on the basis of the information supplied by the bidders.
- h) The evaluation shall be based on the cost of fulfilling the contract in compliance with all commercial, contractual and technical obligations under these bidding documents.
- i) The material covered by these bidding documents is required to be delivered with in the period mentioned in the contract. Bidders are required to base their prices on the time schedule for



delivery. No credit will be given for early completion. Bids offering completion date beyond the maximum designated period shall be rejected.

- j) Any effort made by a bidder to influence in bid evaluation, bid comparison or contract award decision may result in rejection of the bid.
- k) Pakistan Steel Cadet College reserve the right to accept or reject any bid and to annul the bidding process and reject all bids at any time period to award the contract without there by incurring any liability to the effected bidder or bidders or any obligation to inform the effected bidder or bidders of the grounds for Pakistan Steel Cadet College's action.
- l) Pakistan Steel Cadet College requires experts that the bidders would observe the highest standard of ethics during the procurement and execution of this contract.
15. While evaluating the tenders, due consideration will also be given by Pakistan Steel Cadet College to individual unit rates of various item of bill of Quantities, in case of lowest bid, if individual items rates are unbalanced (too high or low) Pakistan Steel Cadet College reserve the right to refer such rate to the bidders for re-adjustment according to normal estimating practice and based on the prevailing market rates. Re-adjustment would be asked to be done only for those rates which are considered to be unbalanced.
16. After opening the offer the College will undertake a detailed study and appraisal of the tender submitted. The study and appraisal of the tenders when completed the successful tenderer will receive the College's written Notice / Letter of Award of the contract. Thereafter the successful tenderer will be required to sign the Agreement with Pakistan Steel Cadet College on prescribed format in the form annexed to the tender with such alterations or additions there to as may be required on non judicial stamp papers equivalent to 0.30% of the contract price within 10 days of the date of Notice / Letter of Award of the Contract. Failure of the successful Tenderer to sign the Agreement and Pay Order shall be a just cause for the annulment of the award of the contract and in the event of such annulment, The Earnest Money of the successful Tenderer will be forfeited to the College without assigning any reason what so ever. Then the College may call for new tenders. In any event, the College reserves the right to reject any or all tenders without assigning any reason and also to waive any formalities in the tenders received if it appears to the College to be in its best interest to do so. Before conclusion of the award the Evaluation Report of the bids will be posted on the website of Pakistan Steel Cadet College and SPPRA and the bidders have right to submit their comments, if any, within 10 days.
17. In the event of failure of work or unsatisfactory performance, Pakistan Steel Cadet College shall have the right to terminate the contract and any amount due against the work done. The work may then be awarded to any other source / agency at the risk and cost of the defaulting contractors.
18. The successful Contractor shall enter into execute an agreement (to be prepared at the cost of contractor) in the prescribed form duly typed on non judicial stamp paper with such modifications as may be considered necessary by the College within (10) days of the date of issue of Notice / Letter of Award and the contractor, as per Board of Revenue, Government of Sindh letter No. CIS/SW/BOR/2009/978 dated 08.08.2009 is under obligation in terms of Sindh Finance Act. , 2009 to stamp duty on the Contract in the shape of non-judicial stamp paper at the rate of Rs. 0.30 for every hundred rupees or part thereof, the amount of the contract along-with the execution of the agreement. The stamp duty shall however be payable at the rates applicable at the time of execution of the agreement / submission of stamp duty.
19. The successful contractor will be required to furnish a pay order of a schedule bank in an amount equal to ten percent (10%) of the contract price. In the event of failure to fulfill the contractual obligations by the contractor or un-satisfactory performance, Pakistan Steel Cadet College shall have the right to terminate the contract and forfeit the 10% amount in the shape of Pay order in favour of Pakistan Steel Cadet College without assigning any reason. On satisfactory completion of the work the



said amount will be released on request of the contractor made to the Engineer and Engineer will recommend for releasing of the same stating that Pakistan Steel Cadet College has no liability against the subject work.

20. The contractor shall be fully responsible for any kind of accident, fatal or otherwise caused while executing the work to himself, his staff or any other person. In all such cases compensation as per rules payable to the claimant shall be on Contractor's account and the responsibility for any injury or damage caused while executing loss of any property, third party whether belonging to Pakistan Steel Cadet College or any third person, shall lie with them and contractor is also responsible for insurance coverage of the employees for any injury accident death according to Law of land. However, Pakistan Steel Cadet College will not indemnify the contractor's or his sub-contractor's loss or manpower, property etc in any case, whatsoever.
21. No bill shall be processed and paid to the contractor unless all the above said legal formalities including signing of the agreement along with stamp duty are completed to the full satisfaction of Pakistan Steel Cadet College.
22. No payment of the bills shall be released to the contractor unless proof of payment professional tax to Provincial Government is provided by him to the "Engineer of Work / Incharge (Bills).
23. Pakistan Steel Cadet College will not carry out responsibility regarding insurance, transport and medical facilities of the labours / manpower etc. of the contractor. The same has to be arranged by the contractor at his own cost.
24. Contractor shall not sublet the work in part or full.
25. Any dispute arising between the parties out of or in connection with this contract agreement shall be referred to arbitration and proceeded within accordance with the rules of arbitration clause under law of Pakistan. The venue of arbitration shall be Karachi, Pakistan.
26. The antecedents of the contract labour employed at the key point (Pakistan Steel Cadet College being an installation enlisted as key Point Category 1-A) will be got verified through local Police / Special Branch. Contractor will be told in writing that he will be personally responsible for the good conduct of each and every member of the contract labour force. All such persons should possess National Registration Card (CNIC) and the contractor will furnish number and other particulars given on the Card to the management for record.
27. If the contractor fails to complete the work within the time set herein, liquidated damages at the rate of 0.05% of the value of contract per day shall be recovered from the contractors subject to the maximum of 10% (ten percent) of the value of contract.
28. PAYMENT
 - a) The contractor shall submit to the Engineer four copies each signed by him or his Agent for interim payment request (if the amount thereof shall justify the issue of an interim certificate) containing a statement in such form as the Engineer may from time to time prescribe showing the amounts to which the contractor may consider himself to be entitled.
 - b) The Engineer shall after examining each such interim payment request certify the amount of payment to the contractor which he shall consider reasonable and proper in respect thereof subject to deduction of retention money or the percentage of retention for security deposit unless the amount retained has reached the limit of retention money stated therein deduction of any other sums which may have become due and payable by the contractor to the College.



- c) The payment against monthly interim payment shall be regarded as payments by way of advance against the final payments and not as payments for works actually done and completed and no such payment of certificate for payment shall be considered as an admission of the due performance of the contract or any part thereof in any respect or accruing of any claim.
- d) Upon the issue of the certificate of completion with respect to the works one half of the Retention Money shall become due and payable to the contractor. The 2nd half shall become due and payable to the contractor after (12) months from the date of successfully completion.
- e) On completion of works a certificate will be issued by the Engineer to the effect that the work has been completed satisfactory and work site has been cleared by Contractor.
29. Any stipulation or offer from participant after opening of bid will not be entertained.
30. The contractor shall confirm that the terms and conditions given above and in the general institutions for the tender enquiry are acceptable to the contractor and that the prices quoted by him are valid for (90) days from the date of tender opening.
31. The bidder shall submit their offers considering all aspects of the work which involve any type of financial impact. The offer must be economical without comprising the quality and quantities of material supplied.
32. Safety will be included in all job planning. This will include providing safe execution equipment and vehicles protective equipment necessary for protection of workmen and establishing methods for safe operation.
33. All necessary safety items / wear must be supplied by the contractor at their own cost and ensure its use by their workers at work place.
34. None of employees, workers or labourer employed by the contractor or his sub-contractor, shall be deemed as he employee, worker or labourer of the Cadet College. The contractor shall follow honour and abide by all the concerned labour laws and their amendment issued time to time by the Government including Workmen Compensation Act 1923 in determining the terms and conditions of services of their workers, labourer and employees of the contractor of which you shall arrange insurance policy from National Insurance Corporation or any approved insurance company. The contractors shall always keep the college indemnified from all claims, demands, compensations and damages which may be claimed from college from any employee, worker or labour employed by the contractor and or his sub-contractor.
35. In case of loss / damage to the property, machinery or manpower of Pakistan Steel Cadet College, the contractor shall be responsible to pay the amount as per loss sustained; otherwise, it will be deducted from the running bills or any other amount in the hand of Pakistan Steel Cadet College.
36. Contractor shall submit an undertaking to the college to abide the safety Programmed and General Safety Requirement prior to commencement of work. The entire liability with regard to injuries disabilities and death shall rest on the contractor.
37. The contractor shall strictly ensure that during performance of the work no child / forced labour will be involved.
38. The contractor is responsible to make payments to his employees strictly in accordance to the Government rules and maintain proper record of such payments for checking by the Engineer of work and other concerned authorities, failing which action may be taken as per rules.



39. The magnitude of the work given in Bill of Quantities may be increased decreased. No variation in rates shall be allowed in case the magnitude of work increase or decreased no compensation for labour & others, remaining idle shall be paid up in case the magnitude of work decrease.

40. **Blacklisting of suppliers and Contractors.** The procuring agencies shall specify mechanism and manner to permanently or temporarily bar, from contractors who either consistently fails to provide satisfactory performance or are found to be indulging in corrupt or fraudulent practices. Such barring action shall be duly publicized and communicated to the Authority.

Provided that any supplier or contractor who is to be blacklisted shall be accorded adequate opportunity of being heard.

41. Time of completion of this work will be 03 months reckoned from the date of commencement of work of Proposed 2nd Horse Riding Club & Recreational Facilities at Pakistan Steel Cadet College (PSCC), Steel Town, Karachi.

42. The bidder are advised in their own interest to visit the site and should assess all the aspects before submitting the bid. For this purpose they may contact Incharge Maintenance, Engineer Nafees Azhar (AM Civil) Township department, Karachi.

43. **Fraud and Corruption.** It is the policy of the PAKISTAN STEEL CADET COLLEGE to require its staff and its vender / contractor / supplier to observe the highest standard of ethics during the selection and execution of such contracts. In pursuance of this policy PAKISTAN STEEL CADET COLLEGE.

(a) Defines, for the purpose of this provision, the terms set forth below:

(i) "Corrupt practice" means the offering, giving, receiving or selecting, public official in the selection process or the execution of a contract.

(ii) "Fraudulent practice" means a misrepresentation or omission of facts in order to influence a selection process or the execution of a contract.

(iii) "Collusive practices" means a scheme or arrangement between two or more vendor / contractor / supplier with or without the knowledge of PAKISTAN STEEL CADET COLLEGE, designed to establish prices at artificial, noncompetitive levels and to deprive PAKISTAN STEEL CADET COLLEGE of the benefits of free and open competition.

(iv) "Coercive practices" means harming or threatening to harm, directly or indirectly, persons or their property to influence their participation in a procurement process, or effect the execution of a contract.

(b) will reject a proposal for award if it determines that the vender / contractor / supplier recommended for award has, directly or through an agent, engaged in corrupt, fraudulent, collusive or coercive practices in competing for the contract in question:-

(c) will sanction a contractor, including declaring the contractor ineligible, either indefinitely or for a stated period of time, to be awarded a Pakistan Steel Cadet College contract if it at any time determines that the contractor has, directly or through an agent, engaged in corrupt, fraudulent, collusive or coercive practices.



44. **Force Majeure.**

- (a) For the purpose of this Contract. "Force Majeure" means an event which is beyond the reasonable control of a party and which makes a party's performance of its obligations under the Contract impossible or so impractical as to be considered impossible under the circumstances, and includes, but is as not limited to, war, riots, civil disorder, earthquake, fire, lookouts or other industrial actions (except where such strikes, lockouts or other industrial actions) are within the power of the party invoking Force Majeure to prevent, confiscation or any other action by government agencies.
- (b) Force Majeure shall not include (I) any event which is caused by the negligence or intentional action of a Party or such parties or agents or been expected to both (A) take into account at the time of the conclusion of this Contract and (B) avoid or overcome in the carrying out of its obligations hereunder.
- (c) Force Majeure shall not include insufficiency of funds or failure to make any payment required hereunder.

45. **Variation of price (Labour and specified Materials (Only for Civil Engineering works))**

- 45.1 No escalation will be paid to the contractor, if any increase or decrease in the cost of materials i.e. Cement, Sand, Pavers, Bamboo & any other things.
- 45.2 No adjustment in the contract prices shall be allowed to the contractor on work done after the expiry of the period of completion, originally which adjustment was allowed in the last interim payment.

46. Kindly return all tender documents along-with drawing issued to you in original signed and stamped at every page.

Responsive bidder is to submit the following documents with bid:

- i) At least 02 No.s of work order required of similar nature of work alongwith successfully completion certificate of last year.
- ii) Minimum Turnover for a year at least 0.5 (M).

College Stamp



Sign & Stamp
by the Contractor

Name of Work: -

ESTIMATE FOR THE WORK OF PROPOSED 2ND HORSE RIDING CLUB & RECREATIONAL FACILITIES @ CADET COLLEGE STEEL TOWN.

Schedule B

SR#	ITEM OF WORK	QTY:	RATE	UNIT	AMOUNT
-----	--------------	------	------	------	--------

Schedule Item

1 Excavation in foundation of Building, Bridges and other structures including degebellling dressing refilling around structure with refilling around structure with excavaed earth Watering and ramming lead upto 5' feet.(B) (In ordinary soil). (S.I # 18-b p).

TOTAL = 551.13 Cft 0 %0, Cft -

2 Cement Concrete brick or stone ballast 1-1/2" to 2" guage ratio 1:4:8 (S.I.No.4b,/P-15)

TOTAL = 91.88 Cft 0 %, Cft -

3 Cement concrete plain including placing, compacting, finishing and curing complete (including screening and washing of stone aggregate without shuttering) (h) Ratio 1:3:6 (S.I.No. 5(h)/C-4)

TOTAL = 469.42 Sft 0 %, Cft -

4 Filling watering and ramming earth in floor with new earth excavated from outside lead upto one chain and left upto 5 feet (S.I.No.22 P-5).

TOTAL = 273.00 Cft - %0, Cft -

5 P/L C C topping cement concrete 1:2:4 in/c surface finishing and dividing into pannels pannels (S.I.No.16d P-42).
2" Thick

TOTAL = 112 Sft - %, Sft -

6 P/L 1:3:6 cement concrete solid block masonry wall 6" above in thickness set in 1:6 cement mortar in G.Floor Super structure in/c racking out joint and curing etc complete (S.I.NO.23/P-19)

TOTAL = 31 Cft 0 %, Cft -

7 R.C.C work including all labour and material except the cost of steel reinforcement and its labour for bending and binding which will be paid separately. This rate also includes all kinds of forms, moulds, lifting, shuttering, curing, rendering and finishing the exposed surface (including screening and washing of shingle (a) R.C.C work in roof slab, beams, columns, rafts, lintels and other structural members laid in situ or precast laid in position. Complete in all respects (i) Ratio 1:2:4 90 lbs. (S.I.No. 6(a)/i/C-4)

TOTAL = 108 Cft - P. Cft -

9 Fabrication of Tor steel reinforcement for cement concrete including cutting, bending, laying in position, making joints and fastening including cost of binding wire (also includes removal of rust from bars. (S.I.No. 7(b)/C-4)

TOTAL = 1,212.83 Lbs

Net Qty: 1,212.83 / 112.00 TOTAL = 10.83 Cwt - P.Cwt -



SR#	ITEM OF WORK	QTY:	RATE	UNIT	AMOUNT
-----	--------------	------	------	------	--------

9 Supplying & Fixing Bamboos 1 to 12 feet long 2"1/2 to 5" dia.

TOTAL = 174 Nos - % Nos: -

10 Erection and removal of centering for R.C.C or plain cement concrete works of partial wood (2ns class) (ii) vertical)

TOTAL = 1,064.50 Cft 0 %, Cft -

11 Making & Fixing fiber glass shade of approved make i/c fixing 4" dia MS vertical pipe 8 to 10ft high making fram of MS squire pipe 4"x2" also fixing the purline of squire pipe 3"x1 1/2" fixing @ site i/c making boxes with 2"x1" squire pipe & fixing fiber glass shade of 3mm with necessary are laps i/c painting 3 coats etc. R.A.

TOTAL = 192 Sft - P. Sft -

12 Providing M.S 16 gauge Pipes specials & clamps etc i/c fixing cutting & fitting complete with & i/c the cost of breaking through wall & roof making good etc painting 2-coats after cleaning the pipe with white zink paint with pigment to match the colour of the building. (S.I.No.1, P-12).

2" dia

TOTAL = 80 Rft - P. Rft -

1 1/2" dia

TOTAL = 22 Rft - P. Rft -

Total Rs:	-
-----------	---



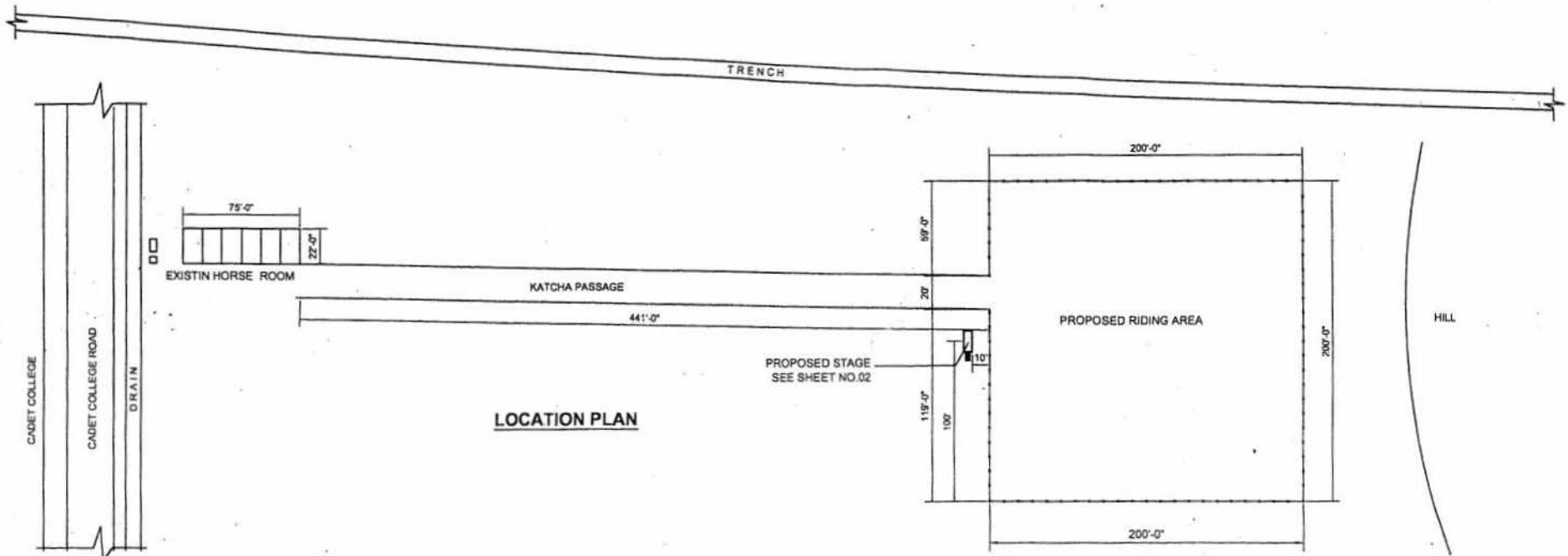

LOCATION PLAN

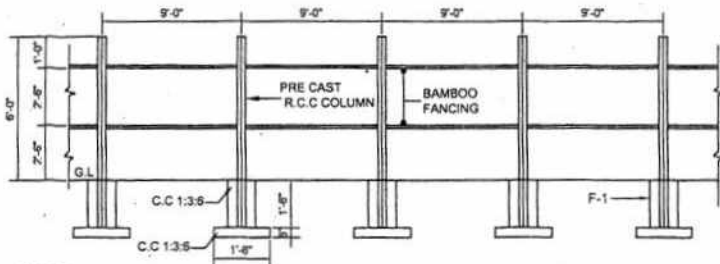

PART PLAN

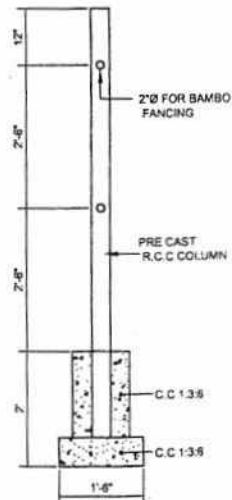

SEC. OF COL.

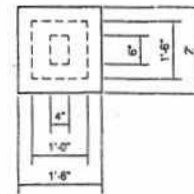

DETAIL F-1

NOTES:-

- 1- REINFORCED CEMENT CONCRETE TO BE 1:2:4 MIX HAVING A MIN. CUBE CRUSHING STRENGTH OF 210 Kg/cm sq @ 28 DAYS.
- 2- ALL REINFORCEMENT TO BE TOR BARS HAVING A MIN. YIELD STRESS OF 4218 kG/cm Sq.
- 3- THE CLEAR COVER TO REINFORCEMENT BARS SHOULD BE AS FOLLOWS,
I- FOOTING = 1.5"
II- COLUMN = 1"

REVISIONS		B		
S/NO	DESCRIPTION	DATE	SIGN	
CENTRAL DESIGN BUREAU				
JOB. PROPOSED 2ND HORSE RIDING CLUB & RECREATIONAL FACILITIES AT CADET COLLEGE, STEEL TOWN				
TITLE. LOCATION PLAN , PART PLAN, SEC & DETAIL				
CUSTOMER CADET COLLEGE	DATE 04-12-2017.	SCALE -	REF.No.	SHEET 1/3
DESIGNED BY Engr. KHAIR-JUN-NISA	DRAWN BY MARVI ABLAM	CHECKED BY Engr. KHAIR-JUN-NISA	APPROVED BY Engr. MUNAIR AHMED JORR	
1	1	6	-	1
1	7	-	0	1
1	-	0	1	-
M	S	-	0	1
0	1	-	0	0



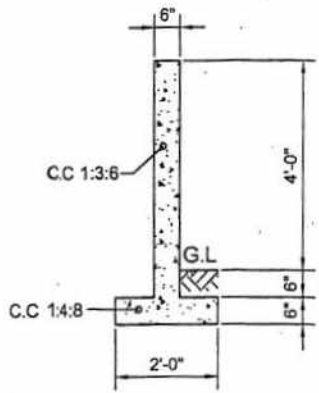

SECTION A-A

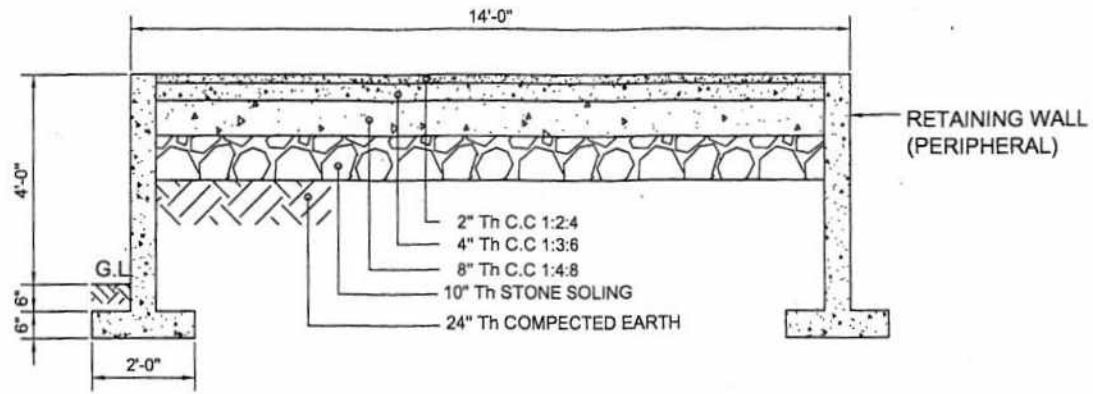

SECTION B-B

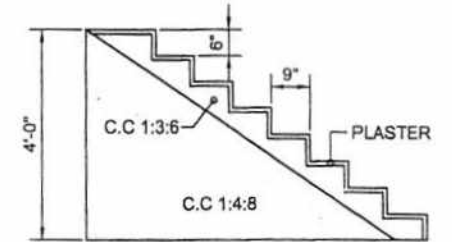

SECTION C-C

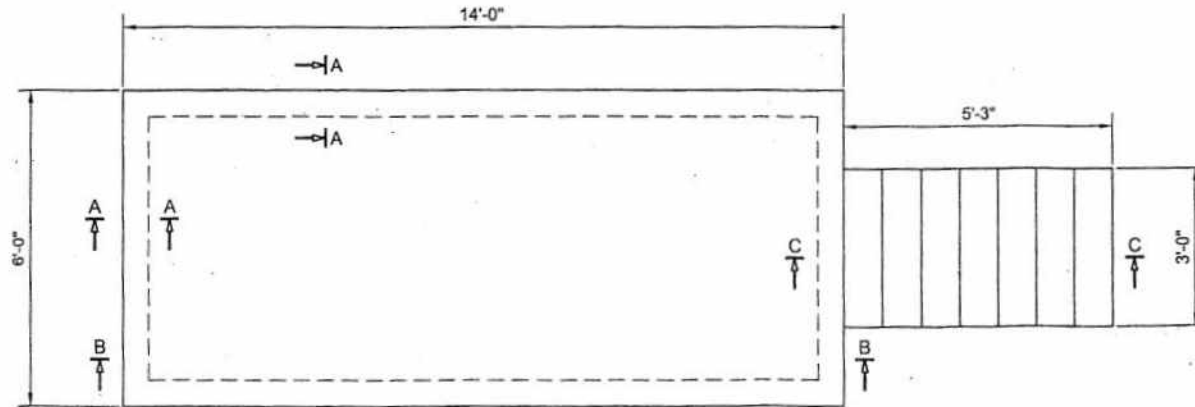

PLAN
STAGE

REVISIONS		B		
		A		
S.NO	DESCRIPTION	DATE	SIGN	
PAKISTAN STEEL				
CENTRAL DESIGN BUREAU				
JOB. PROPOSED 2ND HORSE RIDING CLUB & RECREATIONAL FACILITIES AT CADET COLLEGE, STEEL TOWN				
TITLE. PLAN (STAGE) & SECTIONS				
CUSTOMER	DATE	SCALE	REF.No.	SHEET
CADET COLLEGE	06-12-2017			25
DESIGNED BY	DRAWN BY	CHECKED BY	APPROVED BY	
Egr: KHARUN NISA	MARVI ISLAM	Egr: KHARUN NISA	Egr: M. YAKHUB KHAN	
1	1	6	-	1
7	-	0	1	-
M	S	-	0	2
-	0	2	-	0

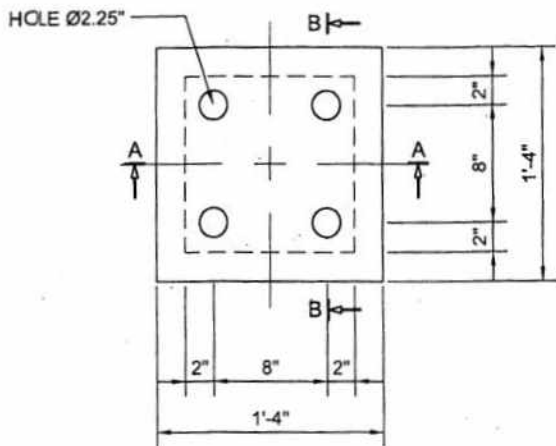

EM-1
(04 NOS)

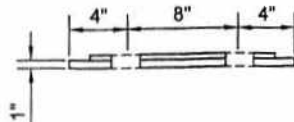

SECTION A-A
(04 NOS)

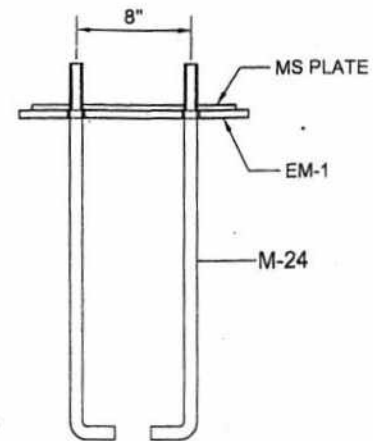

SECTION B-B

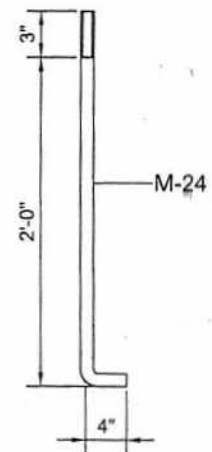

DETAIL OF BOLT
(08 NOS)

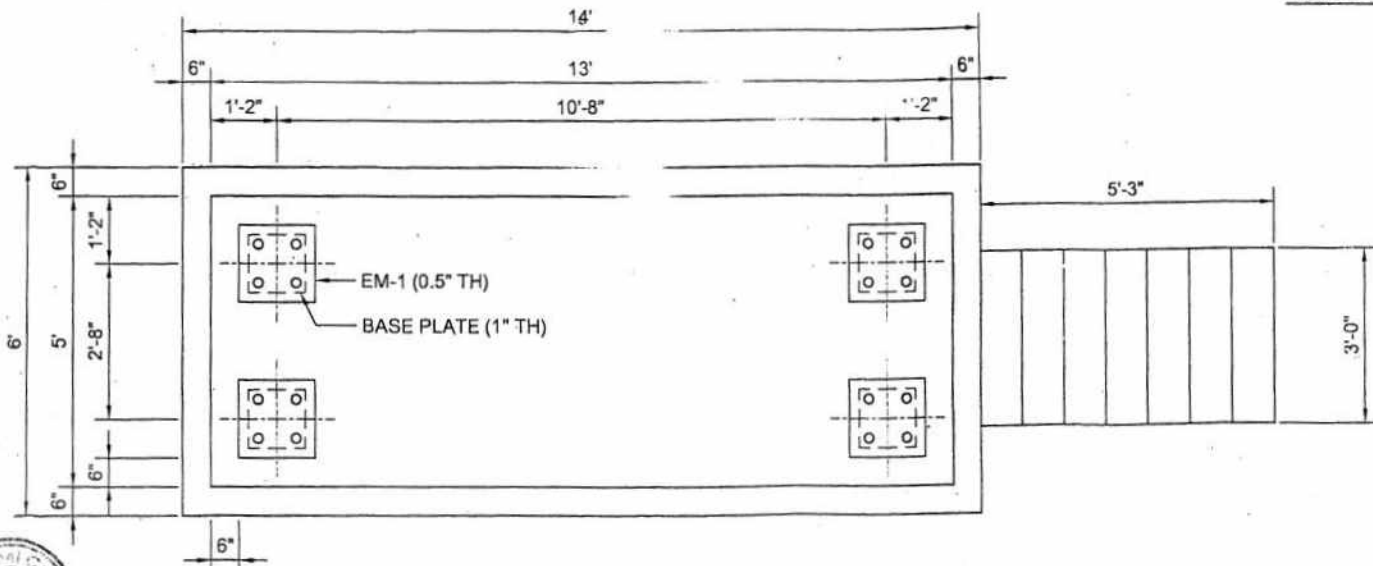

FOOTING PLAN
(STAGE)



REVISIONS	B				
	A				
S.NO	DESCRIPTION		DATE	SIGN	
CENTRAL DESIGN BUREAU					
JOB: PROPOSED 2ND HORSE RIDING CLUB & RECREATIONAL FACILITIES AT CADET COLLEGE, STEEL TOWN					
TITLE: FOOTING PLAN, SECTIONS, EM-1 & DETAIL					
CUSTOMER	DATE	SCALE	REF.No	SHEET	
CADET COLLEGE	06-12-2017			03	
DESIGNED BY	DRAWN BY	CHECKED BY	APPROVED BY		
Engr. KHAIR-UZ-NEESA	MARVI ASLAM	Engr. KHAIR-UZ-NEESA	Engr. KHAIR-UZ-NEESA		
1	1	6	-	1	7
			-	0	1
			-	M	S
			-	0	3
			-	0	0



PAKISTAN STEEL CADET COLLEGE STEEL TOWN KARACHI

GENERAL TERMS & CONDITIONS

TENDER NO. PSCC/HWT/GSF-01/Projects/2018



PAKISTAN STEEL CADET COLLEGE

GENERAL TERMS CONDITIONS

FOR THE WORK OF PROPOSED WALKWAY TO CADET COLLEGE MASJID AT PAKISTAN STEEL CADET COLLEGE (PSCC), STEEL TOWN, KARACHI.

ISSUED TO M/S. _____

1. Sealed offers are invited from reputable / experienced contractors / Firms with the following terms and conditions. Tender documents may be obtained against pay orders of Rs. 1,000/- (Non refundable) drawn in favour of Pakistan Steel Cadet College.
2. The rate(s) must be quoted in words as well as well in figures. Wherever a discrepancy exists between the rate(s) the one written in words shall be taken as correct.
3. Offers received with over writing / cutting, mutilated or doubtful figures will be rejected. Cutting, if at all unavoidable, must be rewritten and must be stamped and signed distinctly. However applying of correcting fluid on the offers is strictly prohibited. In case of violation of these conditions Tender Opening Committee have a right to reject the offer on spot.
4. Conditional tender will not be considered and liable to be rejected by Tender Opening Committee on spot.
5. The rates shall be quoted by the bidders on prescribed BOQs, enclosed herewith. The offers received other than the form of BOQs enclosed shall not be acceptable.
6. Bidders should quote strictly according to tenderer specifications. The alternative / deviated offers shall not be entertained.
7. All columns of tender enquiry / BOQs must be filled in properly and it should be signed and stamped as acceptance of terms and conditions.
8. The validity of tender must be of minimum period of (90)Ninety days from the opening date of tender.
9. Violation of any condition mentioned in tender documents shall be automatically disqualified.
10. The bidders are requested to submit their envelopes containing offers and Earnest Money in separate envelop address to Pakistan Steel Cadet College Steel Town Karachi up to 10:30 am on 27.03.2018. Thereafter tender will be opened on the same day / date at 11:00 am Hours in the presence of Proprietor of the firm or his authorized representative who may like to attend in the college. Bids received after the above deadline shall not be accepted and be returned unopened. Telegraphic / Telex / Fax bids shall be not accepted. The tender documents / BOQs duly signed and stamped must be retuned back in original during opening of the tender.
11. The parties / contractors offering their bids against this tender are required to deposit earnest money of 2% (Two percent) of quoted Bid amount in shape of pay order drawn in favour of Pakistan Steel Cadet College. The validity period of earnest money is (30) days following the date set for the opening of tenders by the college. The earnest money of the successful renderers will be retained until the contract is signed.



12. No tender will be considered by TOC unless it is accompanied by the Earnest Money.

13. Retention money shall be deducted by five percent (5%) on each running bill till the aggregate deductions reached 2.5% of the contract value. The contractors would then be allowed to submit irrevocable bank guarantees for the balance of 2.5%. If the bank guarantee is not submitted by the contractor then deduction @ 5% of the contract value will continue. This amount shall be retained till completion period plus (12) months thereafter. (Only for engineering contracts)

14. EVALUATION CRITERIA

- a) During bid evaluation Pakistan Steel Cadet College may, at its discretion ask the bidders for a clarification of the bid. The request for clarification and the response shall be in writing, and no change in the price or substance of the bid shall be sought.
- b) Pakistan Steel Cadet College will examine the bids to determine whether these are complete or any computational error has been furnished, the documents have been properly signed and the bids are generally found in order.
- c) Arithmetical error will be rectified on the following basis. If there is discrepancy between the unit price and the total price, which is obtained by multiplying the unit price and quantity, or between subtotals and the total price, the unit or subtotal price shall prevail and the total price shall be corrected. If there is a discrepancy between words and figures, the amount in words will prevail. If a bidder does not accept the correction of errors, its bid will be rejected.
- d) Pakistan Steel Cadet College may waive any minor informality, non confirmatory or irregularity in a bid that does not constitute a material deviation whether or not identified by the bidder to its bid and shall not prejudice or effect the relative ranking of any bidder as a result of the technical and commercial evaluation.
- e) Pakistan Steel Cadet College will determine whether each bid is of acceptable quality, is complete and is substantially responsive to the bidding documents for this purpose. Substantially responsive bid is one that conforms to all the terms, conditions and specifications of the bidding documents without material deviations, objection. Conditionally or reservation is one:-
 - i) That effect in any substantial way the scope, quality, quantity or performance of the contract.
 - ii) The limits in any substantial way, inconsistent with the bidding documents issued by Pakistan Steel Cadet College right or the successful bidder's obligations under the contract.
 - iii) Whose rectification would unfairly affect the competitive position of other bidders who are presenting substantially responsive bids.
- f) If a bid is not substantially responsive it will be rejected and may not subsequently be made responsive by the bidder by correction of the non conformity. Determination of a bid's responsiveness is to be based on the contents of the bid itself without recourse to extrinsic evidence.
- g) The bid will be examined and compared with the technical aspects of the bid on the basis of the information supplied by the bidders.
- h) The evaluation shall be based on the cost of fulfilling the contract in compliance with all commercial, contractual and technical obligations under these bidding documents.
- i) The material covered by these bidding documents is required to be delivered within the period mentioned in the contract. Bidders are required to base their prices on the time schedule for



delivery. No credit will be given for early completion. Bids offering completion date beyond the maximum designated period shall be rejected.

- j) Any effort made by a bidder to influence in bid evaluation, bid comparison or contract award decision may result in rejection of the bid.
 - k) Pakistan Steel Cadet College reserve the right to accept or reject any bid and to annul the bidding process and reject all bids at any time period to award the contract without there by incurring any liability to the effected bidder or bidders or any obligation to inform the effected bidder or bidders of the grounds for Pakistan Steel Cadet College's action.
 - l) Pakistan Steel Cadet College requires experts that the bidders would observe the highest standard of ethics during the procurement and execution of this contract.
15. While evaluating the tenders, due consideration will also be given by Pakistan Steel Cadet College to individual unit rates of various item of bill of Quantities, in case of lowest bid, if individual items rates are unbalanced (too high or low) Pakistan Steel Cadet College reserve the right to refer such rate to the bidders for re-adjustment according to normal estimating practice and based on the prevailing market rates. Re-adjustment would be asked to be done only for those rates which are considered to be unbalanced.
16. After opening the offer the College will undertake a detailed study and appraisal of the tender submitted. The study and appraisal of the tenders when completed the successful tenderer will receive the College's written Notice / Letter of Award of the contract. Thereafter the successful tenderer will be required to sign the Agreement with Pakistan Steel Cadet College on prescribed format in the form annexed to the tender with such alterations or additions there to as may be required on non judicial stamp papers equivalent to 0.30% of the contract price within 10 days of the date of Notice / Letter of Award of the Contract. Failure of the successful Tenderer to sign the Agreement and Pay Order shall be a just cause for the annulment of the award of the contract and in the event of such annulment, The Earnest Money of the successful Tenderer will be forfeited to the College without assigning any reason what so ever. Then the College may call for new tenders. In any event, the College reserves the right to reject any or all tenders without assigning any reason and also to waive any formalities in the tenders received if it appears to the College to be in its best interest to do so. Before conclusion of the award the Evaluation Report of the bids will be posted on the website of Pakistan Steel Cadet College and SPPRA and the bidders have right to submit their comments, if any, within 10 days.
17. In the event of failure of work or unsatisfactory performance, Pakistan Steel Cadet College shall have the right to terminate the contract and any amount due against the work done. The work may then be awarded to any other source / agency at the risk and cost of the defaulting contractors.
18. The successful Contractor shall enter into execute an agreement (to be prepared at the cost of contractor) in the prescribed form duly typed on non judicial stamp paper with such modifications as may be considered necessary by the College within (10) days of the date of issue of Notice / Letter of Award and the contractor, as per Board of Revenue, Government of Sindh letter No. CIS/SW/BOR/2009/978 dated 08.08.2009 is under obligation in terms of Sindh Finance Act. , 2009 to stamp duty on the Contract in the shape of non-judicial stamp paper at the rate of Rs. 0.30 for every hundred rupees or part thereof, the amount of the contract along-with the execution of the agreement. The stamp duty shall however be payable at the rates applicable at the time of execution of the agreement / submission of stamp duty.
19. The successful contractor will be required to furnish a pay order of a schedule bank in an amount equal to ten percent (10%) of the contract price. In the event of failure to fulfill the contractual obligations by the contractor or un-satisfactory performance, Pakistan Steel Cadet College shall have the right to terminate the contract and forfeit the 10% amount in the shape of Pay order in favour of Pakistan Steel Cadet College without assigning any reason. On satisfactory completion of the work the



said amount will be released on request of the contractor made to the Engineer and Engineer will recommend for releasing of the same stating that Pakistan Steel Cadet College has no liability against the subject work.

20. The contractor shall be fully responsible for any kind of accident, fatal or otherwise caused while executing the work to himself, his staff or any other person. In all such cases compensation as per rules payable to the claimant shall be on Contractor's account and the responsibility for any injury or damage caused while executing loss of any property, third party whether belonging to Pakistan Steel Cadet College or any third person, shall lie with them and contractor is also responsible for insurance coverage of the employees for any injury accident death according to Law of land. However, Pakistan Steel Cadet College will not indemnify the contractor's or his sub-contractor's loss or manpower, property etc in any case, whatsoever.
21. No bill shall be processed and paid to the contractor unless all the above said legal formalities including signing of the agreement along with stamp duty are completed to the full satisfaction of Pakistan Steel Cadet College.
22. No payment of the bills shall be released to the contractor unless proof of payment professional tax to Provincial Government is provided by him to the "Engineer of Work / Incharge (Bills).
23. Pakistan Steel Cadet College will not carry out responsibility regarding insurance, transport and medical facilities of the labours / manpower etc. of the contractor. The same has to be arranged by the contractor at his own cost.
24. Contractor shall not sublet the work in part or full.
25. Any dispute arising between the parties out of or in connection with this contract agreement shall be referred to arbitration and proceeded within accordance with the rules of arbitration clause under law of Pakistan. The venue of arbitration shall be Karachi, Pakistan.
26. The antecedents of the contract labour employed at the key point (Pakistan Steel Cadet College being an installation enlisted as key Point Category 1-A) will be got verified through local Police / Special Branch. Contractor will be told in writing that he will be personally responsible for the good conduct of each and every member of the contract labour force. All such persons should possess National Registration Card (CNIC) and the contractor will furnish number and other particulars given on the Card to the management for record.
27. If the contractor fails to complete the work with in the time set herein, liquidated damaged at the rate of 0.05% of the value of contract per day shall be recovered from the contractors subject to the maximum of 10% (ten percent) of the value of contract.
28. PAYMENT
 - a) The contractor shall submit to the Engineer four copies each signed by him or his Agent for interim payment request (if the amount thereof shall justify the issue of an interim certificate) containing a statement in such form as the Engineer may from time to time prescribe showing the amounts to which the contractor may consider himself to be entitled.
 - b) The Engineer shall after examining each such interim payment request certify the amount of payment to the contractor which he shall consider reasonable and proper in respect thereof subject to deduction of retention money or the percentage of retention for security deposit unless the amount retained has reached the limit of retention money stated therein deduction of any other sums which may have become due and payable by the contractor to the College.



- c) The payment against monthly interim payment shall be regarded as payments by way of advance against the final payments and not as payments for works actually done and completed and no such payment of certificate for payment shall be considered as an admission of the due performance of the contract or any part thereof in any respect or accruing of any claim.
- d) Upon the issue of the certificate of completion with respect to the works one half of the Retention Money shall become due and payable to the contractor. The 2nd half shall become due and payable to the contractor after (12) months from the date of successfully completion.
- e) On completion of works a certificate will be issued by the Engineer to the effect that the work has been completed satisfactory and work site has been cleared by Contractor.
29. Any stipulation or offer from participant after opening of bid will not be entertained.
30. The contractor shall confirm that the terms and conditions given above and in the general institutions for the tender enquiry are acceptable to the contractor and that the prices quoted by him are valid for (90) days from the date of tender opening.
31. The bidder shall submit their offers considering all aspects of the work which involve any type of financial impact. The offer must be economical without comprising the quality and quantities of material supplied.
32. Safety will be included in all job planning. This will include providing safe execution equipment and vehicles protective equipment necessary for protection of workmen and establishing methods for safe operation.
33. All necessary safety items / wear must be supplied by the contractor at their own cost and ensure its use by their workers at work place.
34. None of employees, workers or labourer employed by the contractor or his sub-contractor, shall be deemed as he employee, worker or labourer of the Cadet College. The contractor shall follow honour and abide by all the concerned labour laws and their amendment issued time to time by the Government including Workmen Compensation Act 1923 in determining the terms and conditions of services of their workers, labourer and employees of the contractor of which you shall arrange insurance policy from National Insurance Corporation or any approved insurance company. The contractors shall always keep the college indemnified from all claims, demands, compensations and damages which may be claimed from college from any employee, worker or labour employed by the contractor and or his sub-contractor.
35. In case of loss / damage to the property, machinery or manpower of Pakistan Steel Cadet College, the contractor shall be responsible to pay the amount as per loss sustained; otherwise, it will be deducted from the running bills or any other amount in the hand of Pakistan Steel Cadet College.
36. Contractor shall submit an undertaking to the college to abide the safety Programmed and General Safety Requirement prior to commencement of work. The entire liability with regard to injuries, disabilities and death shall rest on the contractor.
37. The contractor shall strictly ensure that during performance of the work no child / forced labour will be involved.
38. The contractor is responsible to make payments to his employees strictly in accordance to the Govt. rules and maintain proper record of such payments for checking by the Engineer of work and other concerned authorities, failing which action may be taken as per rules.



39. The magnitude of the work given in Bill of Quantities may be increased decreased. No variation in rates shall be allowed in case the magnitude of work increase or decreased no compensation for labour & others, remaining idle shall be paid up in case the magnitude of work decrease.
40. **Blacklisting of suppliers and Contractors.** The procuring agencies shall specify mechanism and manner to permanently or temporarily bar, from contractors who either consistently fails to provide satisfactory performance or are found to be indulging in corrupt or fraudulent practices. Such barring action shall be duly publicized and communicated to the Authority.
- Provided that any supplier or contractor who is to be blacklisted shall be accorded adequate opportunity of being heard.
41. Time of completion of this work will be 03 months reckoned from the date of commencement of work Proposed Walkway to Cadet College Masjid at Pakistan Steel Cadet College (PSCC), Steel Town, Karachi.
42. The bidder are advised in their own interest to visit the site and should assess all the aspects before submitting the bid. For this purpose they may contact Incharge Maintenance, Engineer Nafees Azhar (AM Civil) Township department, Karachi.
43. **Fraud and Corruption.** It is the policy of the PAKISTAN STEEL CADET COLLEGE to require its staff and its vender / contractor / supplier to observe the highest standard of ethics during the selection and execution of such contracts. In pursuance of this policy PAKISTAN STEEL CADET COLLEGE.
- (a) Defines, for the purpose of this provision, the terms set forth below:
- (i) "Corrupt practice" means the offering, giving, receiving or selecting, public official in the selection process or the execution of a contract.
- (ii) "Fraudulent practice" means a misrepresentation or omission of facts in order to influence a selection process or the execution of a contract.
- (iii) "Collusive practices" means a scheme or arrangement between two or more vendor / contractor / supplier with or without the knowledge of PAKISTAN STEEL CADET COLLEGE, designed to establish prices at artificial, noncompetitive levels and to deprive PAKISTAN STEEL CADET COLLEGE of the benefits of free and open competition.
- (iv) "Coercive practices" means harming or threatening to harm, directly or indirectly, persons or their property to influence their participation in a procurement process, or effect the execution of a contract.
- (b) will reject a proposal for award if it determines that the vender / contractor / supplier recommended for award has, directly or through an agent, engaged in corrupt, fraudulent, collusive or coercive practices in competing tor the contract in question:-
- (c) will sanction a contractor, including declaring the contractor ineligible, either indefinitely or for a stated period of time, to be awarded a Pakistan Steel Cadet College contract if it at any time determines that the contractor has, directly or through an agent, engaged in corrupt, fraudulent, collusive or coercive practices.



44. **Force Majeure.**

Definition

- (a) For the purpose of this Contract. "Force Majeure" means an event which is beyond the reasonable control of a party and which makes a party's performance of its obligations under the Contract impossible or so impractical as to be considered impossible under the circumstances, and includes, but is as not limited to, war, riots, civil disorder, earthquake, fire, lookouts or other industrial actions (except where such strikes, lockouts or other industrial actions) are within the power of the party invoking Force Majeure to prevent, confiscation or any other action by government agencies.
- (b) Force Majeure shall not include (I) any event which is caused by the negligence or intentional action of a Party or such parties or agents or been expected to both (A) take into account at the time of the conclusion of this Contract and (B) avoid or overcome in the carrying out of its obligations hereunder.
- (c) Force Majeure shall not include insufficiency of funds or failure to make any payment required hereunder.

45. **Variation of price (Labour and specified Materials (Only for Civil Engineering works))**

45.1 No escalation will be paid to the contractor, if any increase or decrease in the cost of materials i.e. Cement, Sand, Pavers, & any other things.

45.2 No adjustment in the contract prices shall be allowed to the contractor on work done after the expiry of the period of completion, originally which adjustment was allowed in the last interim payment.

46. Kindly return all tender documents along-with drawing issued to you in original signed and stamped at every page.

Responsive bidder is to submit the following documents with bid:

- i) At least 02 No.s of work order required of similar nature of work alongwith successfully completion certificate of last year.
- ii) Minimum Turnover for a year at least 0.5 (M).

College Stamp



Sign & Stamp
by the Contractor

Name of Work: -

PROPOSED WALK WAY TO CADET COLLEGE MASJID @STEEL TOWN.

Part "A" Schedule B:

SR#	ITEM OF WORK	QTY:	RATE	UNIT	AMOUNT
-----	--------------	------	------	------	--------

Schedule Item

1 Providing & Fixing Cement paving Blocks flooring having size of 197 x 97 x80 mm of city / quddra / cobble shape with pigmented , having strength B/W 5000 psi to 8000 psi i/c filling the joints with hill sand & laying in specified manner / pattern & design etc complete. (S.I.NO.74/P-50)

TOTAL = 2,270 Sft P.Sft -

Total Rs:	-
-----------	---

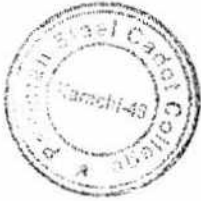

Name of Work: -

PROPOSED WALK WAY TO CADET COLLEGE MASJID @STEEL TOWN.

Part "B" Schedule B

SR#	ITEM OF WORK	QTY:	RATE	UNIT	AMOUNT
-----	--------------	------	------	------	--------

Schedule Item

1 Providing & Fixing Cement paving Blocks flooring having size of 197 x 97 x80 mm of city / quddra / cobble shape with pigmented , having strength B/W 5000 psi to 8000 psi i/c filling the joints with hill sand & laying in specified manner / pattern & design etc complete. (S.I.NO.74/P-50)

TOTAL = 2,608 Sft P.Sft -

Total Rs:	-
-----------	---



4530
427
688
464

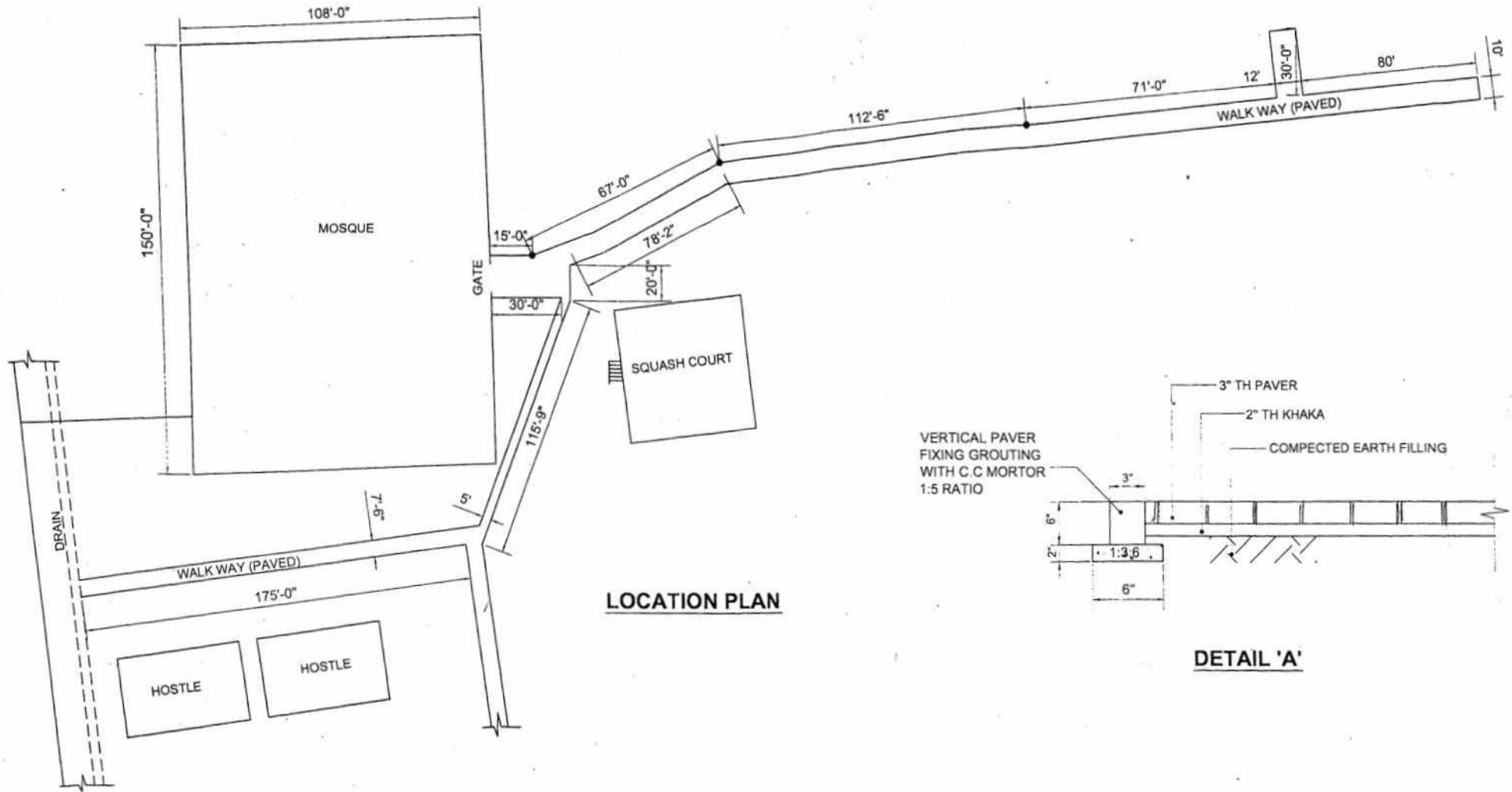

VERTICAL PAVER
FIXING GROUTING
WITH C.C MORTOR
1:5 RATIO

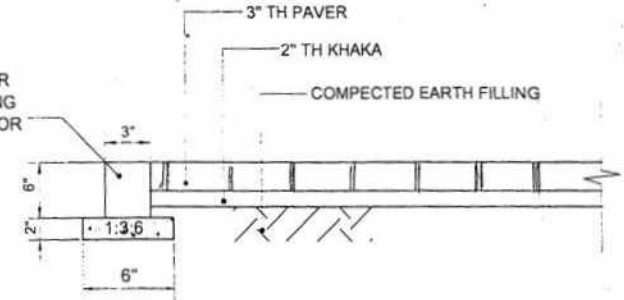

DETAIL 'A'

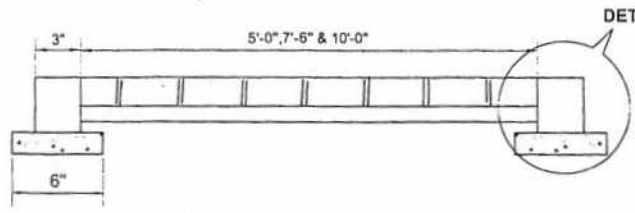

TYP. SEC. OF WALK WAY

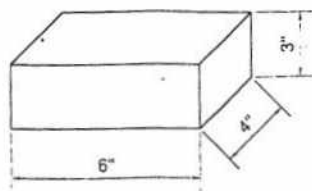

DETAIL OF PAVER

REVISIONS		B		
A	AMENDMENT AS DESIRED BY CADET COLLEGE		20-11-2017	
S.NO	DESCRIPTION	DATE	SIGN	
CENTRAL DESIGN BUREAU JOB. PROPOSED WALK WAY TO CADET COLLEGE MASJID AT STEEL TOWN TITLE. LOCATION PLAN , DETAIL & SECTION				
PAKISTAN STEEL	CUSTOMER	DATE	SCALE	REF.No.
	CADET COLLEGE	14-07-2017.	-	
DESIGNED BY	DRAWN BY	CHECKED BY	APPROVED BY	SHEET
WAYER JAVAD	Per M. Javed	Eng. KHAIR JUNAID	Eng. VJUNARA JAVAR	1/1
1	1	1	-	1
1	7	-	0	1
-	1	-	L	P
-	0	1	-	0
-	1	-	A	

PAKISTAN STEEL CADET COLLEGE

ANNUAL PROCUREMENT PLAN

The detail of annual procurement is given as under:

Sr No.	Description	Estimated Amount	Department	Tendering Procedure
1.	Construction of 2 nd Horse Riding Club & Recreational Facilities	0.5 Million	PSCC	Single-stage Single envelope
2.	Walkway to College Masjid	One Million	PSCC	Single-stage Single envelope

(Prof. Dr. Abdul Rehman Jiskani)
Principal
Dr. Abdul Rehman Jiskani
PRINCIPAL
Pakistan Steel Cadet College
Steel Town, Karachi.



PAKISTAN STEEL CADET COLLEGE



NOTIFICATION FOR COMPLAINT REDRESSAL COMMITTEE

In compliance of the Rule#31 of prevailing Sindh Public Procurement rules 2010 (Amended 2013). Pakistan Steel Cadet College (PSCC) constitutes the Institutional "Complaint Redressal Committee" to address the complaints of the bidders that may occur during the projects proceedings. The composition of the said committee is given as under:

- | | |
|----------------------------------|------------------------------|
| ➤ Prof. Dr. Abdul Rehman Jiskani | Principal PSCC |
| ➤ Asst. Prof. S.M Sohaib | VP (Academics) PSCC |
| ➤ Asst Prof. Abdul Majeed | Vice Principal (Admin), PSCC |

(Prof. Dr. Abdul Rehman Jiskani)
Principal

Dr. Abdul Rehman Jiskani
PRINCIPAL
Pakistan Steel Cadet College
Steel Town, Karachi.



PAKISTAN STEEL CADET COLLEGE



NOTICE

A committee is constituted on the following members for the construction and extension / up-gradation of 2nd Horse Riding School at PSCC. This committee will responsible to evaluate and assess the bids and finalize the best offer regarding above mentioned work.

Internal (Pakistan Steel Cadet College)

a) Mr. Zafar Ali	Major / Adjutant (PSCC)	Convener
b) Mr. Nafees Azhar	AM (Township)	Member
c) Mr. Uzair A. Zubari	DM (Civil)	Member
d) Mr. Nasir Azam	Lecturer / Chairman (Pur. Comm.)	Member
e) Mr. Nazim Altaf Kiyani	Bursar	Member
f) Mr. Khurshid Iqbal	JO / Incharge Maintenance	Member

External

g) Mr. Ihsan Ullah	Deputy Secretary (Academic & Training-II, College Education Department, Sindh
h) Mr. Mehar Muhammad Mangi	Principal (Abdul Razzaq Gabol Govt. Degree College Razzaqabad, Karachi)
i) Mr. Abdul Rasheed Shaikh	Lecturer ((Abdul Razzaq Gabol Govt. Degree College Razzaqabad, Karachi)

c.c to:-

- VP (Academic)
- VP (Admin)
- All Concerned
- Office file

Principal
(Dr. Abdul Rehman Jiskani)

Dr. Abdul Rehman Jiskani
PRINCIPAL
Pakistan Steel Cadet College
Steel Town, Karachi.



PAKISTAN STEEL CADET COLLEGE



NOTICE

A committee is constituted on the following members for the construction of Walkway to College Masjid. This committee will responsible to evaluate and assess the bids and finalize the best offer regarding construction of above mentioned work.

Internal (Pakistan Steel Cadet College)

a) Mr. Imdadullah	Lecturer / AM	Convener
b) Mr. Nafees Azhar	AM (Township)	Member
c) Mr. Uzair A. Zubari	DM (Civil)	Member
d) Mr. Nasir Azam	Lecturer / Chairman (Pur. Comm.)	Member
e) Mr. Nazim Altaf Kiyani	Bursar	Member
f) Mr. Khurshid Iqbal	JO / Incharge Maintenance	Member

External

g) Mr. Ihsan Ullah	Deputy Secretary (Academic & Training-II, College Education Department, Sindh)
h) Mr. Mehar Muhammad Mangi	Principal (Abdul Razzaq Gabol Govt. Degree College Razzaqabad, Karachi)
i) Mr. Abdul Rasheed Shaikh	Lecturer ((Abdul Razzaq Gabol Govt. Degree College Razzaqabad, Karachi)

c.c to:-

- VP (Academic)
- VP (Admin)
- All Concerned
- Office file

Principal
(Dr. Abdul Rehman Jiskani)

Dr Abdul Rehman Jiskani
PRINCIPAL
Pakistan Steel Cadet College
Steel Town, Karachi.