

The Managing Director,
Sindh Public Procurement Regulatory Authority,
Government of Sindh,
Karachi.

SUBJECT: UPLOADING OF 'NOTICE INVITING TENDER (SSWMB/ NIT-9 & 10 of 2017-2018.

Please find enclosed herewith the following documents along with cross Cheque of amounting to Rs. 2000/- (Rupees Two thousand only) (Uploading Charges) with a request to upload the NIT-9 & 10 of 2017-2018, and their bidding documents.

S.No.	Description	Remarks
1.	Notice Inviting Tender (NIT)	Attached
2.	Newspaper Cutting (Daily Dawn, Jang, & Kawish)	Attached
3.	Notification of Procurement Committee	Attached
4.	Notification of Complaint Redressal Committee	Attached
5.	Bidding Documents	Attached (Hard & Soft copy)
6.	Annual Procurement Plan	Attached

The NIT and bidding documents of NIT-9 & 10 of 2017-18 have also been uploaded on our website of SSWMB.

(DR. A. D. SAJJANI)
Managing Director

Copy for information:

1. Executive Director (Operations-I), SSWMB.
2. Executive Director (Finance), SSWMB .
3. Deputy Director (A&F), SPPRA, Karachi.
4. Deputy Director (Procurement / IT / Finance), SSWMB.
5. Master File.

SPPRA INWARD DIARY
 NO : 3492
 DATED : 11-12-17

SINDH SOLID WASTE MANAGEMENT BOARD

Bungalow No. 13, Al-Hamra Housing Society, Shaheed-e-Millat Road, Karachi

Tel: 021 9933 3705 -06; Fax: 021 9933 3707 URL: www.sswmb.gos.pk, email: info@sswmb.gos.pk

NOTICE INVITING TENDER
(SSWMB/NIT-9 & 10/ 2017-18)

Sindh Solid Waste Management Board (SSWMB) invites sealed bids from interested Contractors / Firms for carrying out the Works / Services mentioned below under **SINGLE STAGE – ONE ENVELOPE PROCEDURE**

TENDER REFERENCE NO.	NAME OF WORK	ESTIMATED COST	TENDER COST
NIT-9/2017-18			
NIT-9	Construction of Boundary Wall on different sites of GTS at Karachi. (Civil Works)	55.141 (Million)	Rs.3000/-
NIT-10/2017-18			
NIT-10.1	Transportation of Garbage from GTSs and other areas of District East, Karachi to Landfill Sites.	Open Rate	Rs.3000/- Each
NIT-10.2	Transportation of Garbage from GTSs and other areas of District South, Karachi to Landfill Sites.		
NIT-10.3	Transportation of Garbage from GTSs and other areas of District West, Karachi to Landfill Sites.		
NIT-10.4	Transportation of Garbage from GTSs and other areas of District Malir, Karachi to Landfill Sites.		
TENDER SCHEDULE			
Sr. No.	Schedule	Date & Time	Venue
1.	Issuance of Bidding Documents	From 11-12-2017 to 26-12-2017 (Both days inclusive) during office hours.	Office of Assistant Director (Finance), SSWMB, Bungalow No.13, Al-Hamra Housing Society - Karachi.
2.	Submission of Bids	26-12-2017 at 1500 hours	Committee Room, Sindh Solid Waste Management Board, Bungalow No.13, Al-Hamra Housing Society - Karachi.
3.	Opening of Bids	26-12-2017 at 1530 hours	

- Interested companies can obtain Tender Documents including eligibility criteria upon payment of Tender Document Fee (non-refundable) through **PAY ORDER OR BANK DRAFT of Pak Rs.3,000/- (for each work)** in favor of **Sindh Solid Waste Management Board** as per schedule given above from the office of **Assistant Director (Finance)**, SSWMB during office hours. Alternatively the documents may also be downloaded from the website www.pprasindh.gov.pk or www.sswmb.gos.pk. The companies downloading the documents from the websites must submit Tender Document Fee in the shape of Pay Order or Demand Draft as mentioned above at the time of submission of the bid.
- Bid Security of amount equivalent to 2% of the total quoted bid amount must be attached with the bids.
- Proof of Registration with FBR (NTN / Sales Tax) and Sindh Revenue Board (SRB) is to be submitted with the bids.
- The Bids must be in sealed envelope and submitted **SEPARATE FOR EACH WORK / SERVICES**.
- The envelope must clearly state:
 - Name of the Work (e.g. Transportation of Garbage from GTSs and other areas of District East, Karachi to Landfill Sites and;**
 - Tender Reference Number as mentioned on the bid document (e.g. SSWMB/NIT.10.1/2017-18).**
- In case, the date of opening of bids is declared as a public holiday or non-working day due to force Majeure, the next official working day shall be deemed to be date for issuance, submission and opening of tenders. The time and venue shall remain unchanged.
- Sindh Solid Waste Management Board** shall not be responsible for any cost or expenses incurred by bidding firms and reserves the right to terminate the procurement process at any time subject to relevant provision of SPP Rules, 2010 (Amended 2017).

Deputy Director (Procurement)
Sindh Solid Waste Management Board
Bungalow # 13, Al-Hamra Housing Society, Shaheed e Millat Road, Karachi
Ph # 021-9933 3704-06, Fax # 021-9933 3707 Email Address: info@sswmb.gos.pk website: www.sswmb.gos.pk.



Notice Inviting Tender (SSWMB/NIT-9 & 10/ 2017-18)

Sindh Solid Waste Management Board (SSWMB) invites sealed bids from interested Contractors / Firms for carrying out the Works / Services mentioned below under SINGLE STAGE - ONE ENVELOPE PROCEDURE

Tender Reference No.	Name of Works	Estimated Cost	Tender Cost
NIT-9/2017-18			
NIT-9	Construction of Boundary Wall on different sites of GTS at Karachi. (Civil Works)	55.141 (Million)	Rs.3000/-
NIT-10/2017-18			
NIT-10.1	Transportation of Garbage from GTSS and other areas of District East, Karachi to Landfill Sites.	Open Rate	Rs.3000/- Each
NIT-10.2	Transportation of Garbage from GTSS and other areas of District South, Karachi to Landfill Sites.		
NIT-10.3	Transportation of Garbage from GTSS and other areas of District West, Karachi to Landfill Sites.		
NIT-10.4	Transportation of Garbage from GTSS and other areas of District Malir, Karachi to Landfill Sites.		

Tender Schedule

Sr. No.	Schedule	Date & Time	Venue
1.	Issuance of Bidding Documents	From 11-12-2017 to 26-12-2017 (Both days inclusive) during office hours.	Office of Assistant Director (Finance), SSWMB, Bungalow No.13, Al-Hamra Housing Society - Karachi.
2.	Submission of Bids	26-12-2017 at 1500 hours	Committee Room, Sindh Solid Waste Management Board, Bungalow No.13, Al-Hamra Housing Society - Karachi.
3.	Opening of Bids	26-12-2017 at 1530 hours	

- ⊗ Interested companies can obtain Tender Documents including eligibility criteria upon payment of Tender Document Fee (non_refundable) through **PAY ORDER OR BANK DRAFT** of Pak Rs.3,000/- (for each work) in favor of **Sindh Solid Waste Management Board** as per schedule given above from the office of Assistant Director (Finance), SSWMB during office hours. Alternatively the documents may also be downloaded from the website www.pprasindh.gov.pk or www.sswmb.gos.pk. The companies downloading the documents from the websites must submit Tender Document Fee in the shape of Pay Order or Demand Draft as mentioned above at the time of submission of the bid.
- ⊗ Bid Security of amount equivalent to 2% of the total quoted bid amount must be attached with the bids.
- ⊗ Proof of Registration with FBR (NTN / Sales Tax) and Sindh Revenue Board (SRB) is to be submitted with the bids.
- ⊗ The Bids must be in sealed envelope and submitted **SEPARATE FOR EACH WORK / SERVICES**.
- ⊗ The envelope must clearly state:
 - i. Name of the Work (e.g. Transportation of Garbage from GTSS and other areas of District East, Karachi to Landfill Sites and;
 - ii. Tender Reference Number as mentioned on the bid document (e.g. SSWMB/NIT.10.1/2017-18).
- ⊗ In case, the date of opening of bids is declared as a public holiday or non-working day due to force Majeure, the next official working day shall be deemed to be date for issuance, submission and opening of tenders. The time and venue shall remain unchanged.
- ⊗ Sindh Solid Waste Management Board shall not be responsible for any cost or expenses incurred by bidding firms and reserves the right to terminate the procurement process at any time subject to relevant provision of SPP Rules, 2010 (Amended 2017).

Deputy Director (Procurement)
Sindh Solid Waste Management Board
Bungalow # 13, Al-Hamra Housing Society, Shaheed e Millat Road, Karachi
Ph # 021-9933 3704-06, Fax # 021-9933 3707 Email Address: info@sswmb.gos.pk website: www.sswmb.gos.pk

Notice Inviting Tender (SSWMB/NIT-9 & 10/ 2017-18)

Sindh Solid Waste Management Board (SSWMB) invites sealed bids from interested Contractors / Firms for carrying out the Works / Services mentioned below under SINGLE STAGE - ONE ENVELOPE PROCEDURE

Tender Reference No.	Name of Works	Estimated Cost	Tender Cost
NIT-9/2017-18			
NIT-9	Construction of Boundary Wall on different sites of GTS at Karachi. (Civil Works)	55.141 (Million)	Rs.3000/-
NIT-10/2017-18			
NIT-10.1	Transportation of Garbage from GTSs and other areas of District East, Karachi to Landfill Sites.	Open Rate	Rs.3000/- Each
NIT-10.2	Transportation of Garbage from GTSs and other areas of District South, Karachi to Landfill Sites.		
NIT-10.3	Transportation of Garbage from GTSs and other areas of District West, Karachi to Landfill Sites.		
NIT-10.4	Transportation of Garbage from GTSs and other areas of District Malir, Karachi to Landfill Sites.		

Tender Schedule

Sr. No.	Schedule	Date & Time	Venue
1.	Issuance of Bidding Documents	From 11-12-2017 to 26-12-2017 (Both days inclusive) during office hours.	Office of Assistant Director (Finance), SSWMB, Bungalow No.13, Al-Hamra Housing Society - Karachi.
2.	Submission of Bids	26-12-2017 at 1500 hours	Committee Room, Sindh Solid Waste Management Board, Bungalow No.13, Al-Hamra Housing Society - Karachi.
3.	Opening of Bids	26-12-2017 at 1530 hours	

- Interested companies can obtain Tender Documents including eligibility criteria upon payment of Tender Document Fee (non_refundable) through **PAY ORDER OR BANK DRAFT** of Pak Rs.3,000/- (for each work) in favor of **Sindh Solid Waste Management Board** as per schedule given above from the office of **Assistant Director (Finance)**, SSWMB during office hours. Alternatively the documents may also be downloaded from the website www.pprasindh.gov.pk or www.sswmb.gos.pk. The companies downloading the documents from the websites must submit Tender Document Fee in the shape of Pay Order or Demand Draft as mentioned above at the time of submission of the bid.
- Bid Security of amount equivalent to 2% of the total quoted bid amount must be attached with the bids.
- Proof of Registration with FBR (NTN / Sales Tax) and Sindh Revenue Board (SRB) is to be submitted with the bids.
- The Bids must be in sealed envelope and submitted SEPARATE FOR EACH WORK / SERVICES.
- The envelope must clearly state:
 - i. Name of the Work (e.g. Transportation of Garbage from GTSs and other areas of District East, Karachi to Landfill Sites and;
 - ii. Tender Reference Number as mentioned on the bid document (e.g. SSWMB/NIT.10.1/2017-18).
- In case, the date of opening of bids is declared as a public holiday or non-working day due to force Majeure, the next official working day shall be deemed to be date for issuance, submission and opening of tenders. The time and venue shall remain unchanged.
- Sindh Solid Waste Management Board shall not be responsible for any cost or expenses incurred by bidding firms and reserves the right to terminate the procurement process at any time subject to relevant provision of SPP Rules, 2010 (Amended 2017).

Deputy Director (Procurement)
Sindh Solid Waste Management Board
Bungalow # 13, Al-Hamra Housing Society, Shaheed e Millat Road, Karachi
Ph # 021-9933 3704-06, Fax # 021-9933 3707 Email Address: info@sswmb.gos.pk website: www.sswmb.gos.pk

INF/KRY/5086/17

ٽينڊر گھراڻن جو نوٽيس (SSWMB/NIT-9 & 10/ 2017-18)

سندھ سالب ویسٹ مئنجمینٹ بورڊ (ايس ايس ڊبليو ايمر بي) کي هيٺ ڄاڻايل ڪمن/خدمتن کي انجام ڏيڻ لاءِ هڪ مرحلو - پ لفافا طريقيڪار تحت دلچسپي رکندڙ ٺيڪيدارن/فرمن کان مهربند آڇون گھربل آهن.

ٽينڊر ريفريٽس نمبر ڪر جو نالو ڪٿيل لاڳت ٽينڊر جي قيمت

NIT-9/2017-18

NIT-9	ڪراچي ۾ جي ٽي ايس جي مختلف سائٽس تي چار ديوراي جي تعمير (سول ورڪس)	55.141 ملين	3000/- روپيا
-------	--	-------------	--------------

NIT-10/2017-18

NIT-10.1	جي ٽي ايس ۽ ضلع شرقي، ڪراچي جي ٻين علائقن مان لينڊ فل سائٽس تائين گند ڪڍڻ جي ٽرانسپورٽيشن	ڪٿيل آڱهه	3000/- روپيا في
NIT-10.2	جي ٽي ايس ۽ ضلع جنوبي، ڪراچي جي ٻين علائقن مان لينڊ فل سائٽس تائين گند ڪڍڻ جي ٽرانسپورٽيشن		
NIT-10.3	جي ٽي ايس ۽ ضلع غربي، ڪراچي جي ٻين علائقن مان لينڊ فل سائٽس تائين گند ڪڍڻ جي ٽرانسپورٽيشن		
NIT-10.4	جي ٽي ايس ۽ ضلع ملير، ڪراچي جي ٻين علائقن مان لينڊ فل سائٽس تائين گند ڪڍڻ جي ٽرانسپورٽيشن		

ٽينڊر ٽيبل

نمبر شمار	شيديوول	تاريخ ۽ وقت	هنڌ
1	واڪ دستاويزن جو اجرا	2017-12-11 کان 2017-12-26 (ٻنهي ڏينهن سميت) ڪر ڪار وارن وقتن دوران	آفيس اسسٽنٽ ڊائريڪٽر (فنانس) ايس ايس ڊبليو ايمر بي، بنگلو نمبر 13، الحمرا هائوسنگ سوسائٽي، ڪراچي
2	آڇن جو جمع ڪرائڻ	2017-12-26 ٽيپري 3 وڳي	ڪميٽي روم، سندھ سالب ویسٹ مئنجمینٹ بورڊ، بنگلو نمبر 13، الحمرا هائوسنگ سوسائٽي، ڪراچي
3	آڇن جو کولڻ	2017-12-26 ٽيپري 3:30 وڳي	

- دلچسپي رکندڙ ڪمپنيون ٽينڊر دستاويزات بشمول اهليت جو معيار ٽينڊر دستاويز جي في 3000 پاڪستاني روپيا (هر ڪرا لاءِ) جي ادائگي (ناقابل واپسي) ٻڌڻي بي آرڊر يا بينڪ ڊرافٽ نالي سندھ سالب ویسٹ مئنجمینٹ بورڊ ڪرڻ تي مٿي ڄاڻايل شيديوول مطابق آفيس اسسٽنٽ ڊائريڪٽر (فنانس) ايس ايس ڊبليو ايمر بي وٽان آفيس وقتن دوران حاصل ڪري سگهجن ٿا. متبادل طور تي دستاويز ويب سائٽ www.pprasinidh.gov.pk يا www.sswmb.gos.pk تان به ڏاڻو لوڊ ڪري سگهجن ٿا. ويب سائٽ تان دستاويز ڏاڻو لوڊ ڪندڙ ڪمپني کي لازمي طور تي ٽينڊر دستاويز جي في بي آرڊر يا ڊمانڊ ڊرافٽ جي صورت ۾ جيئن مٿي ڄاڻايل آهي آڇ جمع ڪرائڻ وقت ادا ڪرڻا پوندا.

- جملي درج ڪيل آڇ جي ماليت جي 2% جي مساوي رقم جي سوٽي رقم لازمي طور آڇن سان گڏ شامل ڪئي وڃي.
- ايڇ بي آر (اين ٽي اين/اين سيز ٽيڪس) ۽ سنڌ روئينيو بورڊ (ايس آر بي) وٽ رجسٽريشن جو ثبوت آڇن سان گڏ جمع ڪرائڻو پوندو.
- آڇون لازمي طور تي مهربند لفظي پر هجن ۽ هر هڪ ڪم/خدمت لاءِ ڌار ڌار آڇون جمع ڪرايون وڃن.
- لفظي تي واضح طور تي درج ڪيو وڃي.

آ ڪر جو نالو (مثال جي طور تي جي ٽي ايس ۽ ضلع شرقي، ڪراچي جي ٻين علائقن مان لينڊ فل سائٽس تائين گند ڪڍڻ جي ٽرانسپورٽيشن ۽
آ ٽينڊر ريفريٽس نمبر جيئن ته واڪ دستاويزن ۾ ڄاڻايل آهي (مثال جي طور تي NIT-10-1/2017-18) (SSWMB/NIT-10-1/2017-18)

- آڇن کائڻ جي تاريخ تي عام موڪل جو اعلان ڪرڻ يا ڪنهن قدر تي آفت سبب آفيس جو ڪم ڪار ٽيڙ ڪري روٽنڊ ڪم واري ڏينهن کي ٽينڊر جي اجرا، جمع ڪرائڻ ۽ کولڻ جي تاريخ تصور ڪيو وڃي. وقت ۽ هنڌ ۾ ڪا به تبديلي نه ڪئي ويندي.

- سندھ سالب ویسٹ مئنجمینٹ بورڊ آڇون جمع ڪرائيندڙ فرمن پاران خرچ ڪيل ڪنهن قسم جي خرچن يا رقم لاءِ ذميوار نه هوندي ۽ ايس بي بي رولز 2010 (ترميمريل 2017) جي واسطيدار شتن مطابق ڪنهن به وقت پروڪيورمينٽ جو عمل رد ڪرڻ جو حق محفوظ رکي ٿي.

ڊپٽي ڊائريڪٽر (پروڪيورمينٽ)

سندھ سالب ویسٹ مئنجمینٹ بورڊ

بنگلور نمبر 13، الحمرا هائوسنگ سوسائٽي، ٽيپڊ ملٽ روڊ، ڪراچي - فون نمبر - 021-9933 3704-06 021-9933 3707 - ڊيڪٽر نمبر - 021-9933 3707 - ايميل ائڊريس - info@sswmb.gos.pk - ويب سائٽ - www.sswmb.gos.pk



07-12-2017

Sindh
Solid Waste Management
Board

حکومت سندھ
سندھ سائلڈ ویسٹ مینجمنٹ بورڈ



نوٹس پبلی ٹینڈرز (SSWMB/NIT-9 & 10/ 2017-18)

سندھ سائلڈ ویسٹ مینجمنٹ بورڈ (ایس ایس ڈبلیو ایم بی) کو درج ذیل کاموں / خدمات کی انجام دہی کے لیے ایک مرحلہ-دو لگانہ طریقہ کار کے تحت دلچسپی رکھنے والے ٹھیکیداروں / فرموں سے سہ ماہیہ پیشکشیں مطلوب ہیں۔

ٹینڈر نمبر	تعمینی لاگت	کام کا نام	ٹینڈر ریٹرنس نمبر
NIT-9/2017-18			
NIT-9	55.141 ملین	کراچی میں جی ٹی ایس کی مختلف سائٹس پر چارہ پھاری کی تعمیر (سول ورکس)	3000/- روپے
NIT-10/2017-18			
NIT-10.1	اوپن ریفٹ	جی ٹی ایس اور ضلع شرقی، کراچی کے دیگر علاقوں سے لینڈفل سائٹس تک کوڈا کرکٹ کی ٹرانسپورٹیشن	3000/- روپے
NIT-10.2		جی ٹی ایس اور ضلع جنوبی، کراچی کے دیگر علاقوں سے لینڈفل سائٹس تک کوڈا کرکٹ کی ٹرانسپورٹیشن	
NIT-10.3		جی ٹی ایس اور ضلع غربی، کراچی کے دیگر علاقوں سے لینڈفل سائٹس تک کوڈا کرکٹ کی ٹرانسپورٹیشن	
NIT-10.4		جی ٹی ایس اور ضلع میر کراچی کے دیگر علاقوں سے لینڈفل سائٹس تک کوڈا کرکٹ کی ٹرانسپورٹیشن	

ٹینڈر شیڈول

نمبر شمار	ٹینڈر	تاریخ اور وقت	مقام
1	بڈنگ دستاویزات کا اجرا	26-12-2017 تا 11-12-2017 (بشمول دونوں دن) اوقات کار کے دوران	دفتر اسسٹنٹ ڈائریکٹر (فنانس) ایس ایس ڈبلیو ایم بی، بنگلہ نمبر 13، انٹرا ہاؤسنگ سوسائٹی، کراچی
2	پیشکشوں کا جمع کرنا	26-12-2017 بوقت دن کے تین بجے	کمپنی روم، سندھ سائلڈ ویسٹ مینجمنٹ بورڈ، بنگلہ نمبر 13، انٹرا ہاؤسنگ سوسائٹی، کراچی
3	پیشکشوں کا کھولا جانا	26-12-2017 بوقت دن کے ساڑھے تین بجے	

دلچسپی رکھنے والی کمپنیاں ٹینڈر دستاویزات بشمول اہلیت کا معیار ٹینڈر دستاویزات کی نمبر 3,000/- روپے (برائے فی کام) کی ادائیگی (قابل واپسی) بذریعہ چیک آرڈر یا بینک ڈرافٹ نام سندھ سائلڈ ویسٹ مینجمنٹ بورڈ کرنے پر درج بالا شیڈول کے مطابق دفتر اسسٹنٹ ڈائریکٹر (فنانس) ایس ایس ڈبلیو ایم بی، سے اوقات کار کے دوران حاصل کر سکتی ہیں۔ متبادل طور پر دستاویزات ویب سائٹ www.pprasindh.gov.pk یا www.sswmb.gos.pk سے بھی ڈاؤن لوڈ کی جا سکتی ہیں۔ ویب سائٹس سے دستاویزات ڈاؤن لوڈ کرنے والی کمپنیوں کو لازمی طور پر ٹینڈر دستاویزات کی نمبر 13، انٹرا ہاؤسنگ سوسائٹی، کراچی میں، جیسا کہ اوپر درج کیا گیا ہے، پیشکش جمع کرتے وقت ادا کرنا ہوگی۔

- کل درج کردہ پیشکش کی مالیت کے 2 فیصد کے مساوی رقم کی ضمانت لازمی طور پر پیشکشوں کے ساتھ منسلک کی جائے۔
- ایف بی آر (این بی این / سیکرنس) اور سندھ ریٹینڈ بورڈ (ایس آر بی) کے پاس رجسٹریشن کا چھوٹا پیشکشوں کے ساتھ جمع کرنا ہوگا۔
- پیشکشیں لازمی طور پر سہ ماہیہ لگانے میں ہوں اور ہر ایک کام / خدمات کے لیے الگ الگ پیشکش جمع کرانی جائے۔
- لگانے پر واضح طور پر درج کیا جائے:
- 1۔ کام کا نام (مثال کے طور پر جی ٹی ایس اور ضلع شرقی، کراچی کے دیگر علاقوں سے لینڈفل سائٹس تک کوڈا کرکٹ کی ٹرانسپورٹیشن اور
- 2۔ ٹینڈر ریٹرنس نمبر جیسا کہ بڈنگ دستاویزات میں درج ہے (مثال کے طور پر 10.1/2017-18/SSWMB)۔
- پیشکشیں کھلنے کی تاریخ پر عام تعطیل کا اعلان کیے جانے یا کسی قدرتی آفت کے باعث دفتر کی امور انجام نہ دینے جانے کے سبب کھلنے والے دن کو ٹینڈر کے اجراء جمع کرانے اور کھولنے کے لیے تاریخ تصدیق کیا جائے۔ وقت اور مقام میں کوئی تبدیلی نہیں کی جائے گی۔
- سندھ سائلڈ ویسٹ مینجمنٹ بورڈ پیشکشیں جمع کرانے والی فرموں کی جانب سے صرف کیے جانے والے کسی قسم کے اخراجات یا رقم کے لیے ذمہ دار نہ ہوگا اور ایس بی پی ریٹرن 2010 (ترمیم شدہ 2017) کی متعلقہ سیکشن کے مطابق کسی بھی وقت پروویڈنٹ فنڈ کا استعمال ممنوع کرنے کا حق محفوظ رکھتا ہے۔

ڈپٹی ڈائریکٹر (پروویڈنٹ فنڈ)

سندھ سائلڈ ویسٹ مینجمنٹ بورڈ

بنگلہ نمبر 13، انٹرا ہاؤسنگ سوسائٹی شہید ملت روڈ، کراچی۔ فون نمبر - 021-9933 3704-06، فیکس نمبر - 021-9933 3707۔ ای میل ایڈریس - info@sswmb.gos.pk۔ ویب سائٹ - www.sswmb.gos.pk

INF/KRY/5086/17



ORDER

With the approval of the Competent Authority i.e worthy Secretary Local Government Department, Government of Sindh and in pursuance of Rule-7 read with Rule-67 of Sindh Public Procurement Regulatory Authority, Rules-2010 (Amended 2017), Procurement Committees No.I, II and III of Sindh Solid Waste Management Board, are hereby re-constituted, as under: -

PROCUREMENT COMMITTEE-I (Operation/Project Purpose)

1.	Concerned Executive Director (Ops), SSWMB	Chairman
2.	Deputy Director (Finance), SSWMB	Member
3.	Representative of Public Health Engineering Department	Member
4.	Representative of Rural Development Deptt./DMC (s)	Member
5.	Director/Deputy Director (Procurement), SSWMB	Member/Secretary

PROCUREMENT COMMITTEE-II

(Procurement of + 1 Million for Head Office, SSWMB)

1.	Secretary, SSWMB	Chairman
2.	Deputy Director (Finance), SSWMB	Member
3.	Representative of Industries Department/PHE Deptt.	Member
4.	Representative of Rural Development Deptt./DMC (s)	Member
5.	Director/Deputy Director (Procurement), SSWMB	Member/Secretary

PROCUREMENT COMMITTEE-III

(Procurement of less than 1 Million for Head Office, SSWMB)

1.	Secretary, SSWMB	Chairman
2.	Deputy Director (Finance), SSWMB	Member
3.	Representative of Rural Development Deptt./DMC (s)	Member

Contd...P/2

Ref No: SEC/SSWMB/2015/87
GOVERNMENT OF SINDH
Dated: 19.March.2015

Notification

In line with requirements under Rule 31 of SPPRA Rules 2010, the following Complaint Redressal Committee (CRC) is constituted for all the procurements in Sindh Solid Waste Management Board.

Complaint Redressal Committee:

- | | |
|--|----------|
| 1. Managing Director
Sindh Solid Waste Management Board | Chairman |
| 2. Representative of Accountant General Sindh | Member |
| 3. Independent Professional from the relevant field | Member |

Functions and Responsibilities of the Committee

The complaint redressal committee upon receiving a complaint from an aggrieved bidder may, if satisfied;

- Prohibit the Procurement Committee of SSWMB from action or deciding in a manner inconsistent with the SPPRA rules.
- Annul in whole or in a part, any unauthorized act or decision of the Procurement Committee.
- Decide a case to be declared as mis-procurement if material violation of Act, Rules, Regulations, orders, instruction or any other law relating to public Procurement, has been established.
- Reverse any decision of the Procurement Committee or substitute its own decision for such a decision.
- The Complaint Redressal Committee shall announce its decision within seven days and intimate the same to the bidder and the SPPRA within three working days. If the committee fails to arrive at the decision within seven days, the complaint shall stand transferred to the Review Committee as per SPPRA Rules 2010.

(Dr. Mir Nusrat Ali Panhwar)
Secretary

19/3/2015

Sindh Solid Waste Management Board

Copy for information to:

- Accountant General Sindh
- Managing Director, Sindh Solid Waste Management Board
- Managing Director, SPPRA Government of Sindh
- Members of CRC Committee
- Office Copy

GOVERNMENT OF SINDH

Say No to Corruption

Tender Documents / RFP
SSWMB/NIT-9/2017-18

[Single Stage – One Envelope Procedure
As per Rule 46(1) of Sindh Public Procurement Rules, 2010 (Amended 2013)]

Work -9
CONSTRUCTION OF BOUNDARY WALL ON DIFFERENT SITES OF GTS AT
KARACHI (CIVIL WORKS).

Estimated Cost:	Rs.50.128 Million	Tender Cost:	3,000/-
Time Limit:	12 Months		
To be Opened on:	26-12-2017 at 1530 hours	Validity of Tender:	90 days

Executive Director (Operations-I)

Note:

- i. *This document is also available on SPPRA website and can be downloaded and submitted on the day and time as mentioned in the NIT along with Tender Cost fee.*
- ii. *All bidders are required to sign and stamp each and every page of the bidding document before submission, else their bids shall be considered non-responsive.*
- iii. *SSWMB reserved the rights change of site /location of Garbage Transfer Station (GTS)*

Client:

Bungalow No. 13 Al-Hamrah Housing Society, Shaheed e Millat Road, Karachi
Tel No. 021-9933 3706 - 07 Fax 021-9933 3700
URL: www.sswmb.gos.pk Email: info@sswmb.gos.pk



BIDDING DOCUMENT FOR
(Reference No. SSWMB-NIT-9/2017-18)

Work-9
Construction of Boundary Wall on different Sites of GTS at Karachi
(Civil Works)

Note:- SSWMB reserved the rights change of site /location of Garbage Transfer Station (GTS)

BID PRICE:

TENDER DOCUMENT
(CIVIL WORK)

Date & time of opening:	26-12-2017 at 1530 hours
Place of opening:	Committee Room, Sindh Solid Waste Management Board, bungalow# 13, Al-Hamra, Housing society, Shaheed e Millat Road – Karachi
Date of issue:	
Name of Contractor:	
Contractor's Representative	
Name & Signature of Tender Issuing Officer:	
Bid Price:	
Amount in Numbers [Pak Rs. _____.]	
Amount in Figures [Pak Rs. _____.]	

SEAL AND SIGNATURE OF THE CONTRACTOR

Executive Director (Operation-I)

Contractor

INVITATION FOR BIDS

NOTICE INVITING TENDER
(SSWMB/NIT-9 & 10/ 2017-18)

Sindh Solid Waste Management Board (SSWMB) invites sealed bids from interested Contractors / Firms for carrying out the Works / Services mentioned below under **SINGLE STAGE – ONE ENVELOPE PROCEDURE**

TENDER REFERENCE NO.	NAME OF WORK	ESTIMATED COST	TENDER COST
NIT-9/2017-18			
NIT-9	Construction of Boundary Wall on different sites of GTS at Karachi. (Civil Works)	55.141 (Million)	Rs.3000/-
NIT-10/2017-18			
NIT-10.1	Transportation of Garbage from GTSs and other areas of District East, Karachi to Landfill Sites.	Open Rate	Rs.3000/- Each
NIT-10.2	Transportation of Garbage from GTSs and other areas of District South, Karachi to Landfill Sites.		
NIT-10.3	Transportation of Garbage from GTSs and other areas of District West, Karachi to Landfill Sites.		
NIT-10.4	Transportation of Garbage from GTSs and other areas of District Malir, Karachi to Landfill Sites.		
TENDER SCHEDULE			
Sr. No.	Schedule	Date & Time	Venue
1.	Issuance of Bidding Documents	From 11-12-2017 to 26-12-2017 (Both days inclusive) during office hours.	Office of Assistant Director (Finance), SSWMB, Bungalow No.13, Al-Hamra Housing Society - Karachi.
2.	Submission of Bids	26-12-2017 at 1500 hours	Committee Room, Sindh Solid Waste Management Board, Bungalow No.13, Al-Hamra Housing Society - Karachi.
3.	Opening of Bids	26-12-2017 at 1530 hours	

- Interested companies can obtain Tender Documents including eligibility criteria upon payment of Tender Document Fee (non-refundable) through **PAY ORDER OR BANK DRAFT of Pak Rs.3,000/- (for each work)** in favor of **Sindh Solid Waste Management Board** as per schedule given above from the office of **Assistant Director (Finance)**, SSWMB during office hours. Alternatively the documents may also be downloaded from the website www.pprasindh.gov.pk or www.sswmb.gos.pk. The companies downloading the documents from the websites must submit Tender Document Fee in the shape of Pay Order or Demand Draft as mentioned above at the time of submission of the bid.
- Bid Security of amount equivalent to 2% of the total quoted bid amount must be attached with the bids.
- Proof of Registration with FBR (NTN / Sales Tax) and Sindh Revenue Board (SRB) is to be submitted with the bids.
- The Bids must be in sealed envelope and submitted **SEPARATE FOR EACH WORK / SERVICES**.
- The envelope must clearly state:
 - Name of the Work (e.g. Transportation of Garbage from GTSs and other areas of District East, Karachi to Landfill Sites and;
 - Tender Reference Number as mentioned on the bid document (e.g. SSWMB/NIT.10.1/2017-18).
- In case, the date of opening of bids is declared as a public holiday or non-working day due to force Majeure, the next official working day shall be deemed to be date for issuance, submission and opening of tenders. The time and venue shall remain unchanged.
- Sindh Solid Waste Management Board shall not be responsible for any cost or expenses incurred by bidding firms and reserves the right to terminate the procurement process at any time subject to relevant provision of SPP Rules, 2010 (Amended 2017).

Deputy Director (Procurement)
Sindh Solid Waste Management Board
Bungalow # 13, Al-Hamra Housing Society, Shaheed e Millat Road, Karachi
Ph # 021-9933 3704-06, Fax # 021-9933 3707 Email Address: info@sswmb.gos.pk website: www.sswmb.gos.pk.

TABLE OF CONTENTS

<i>Clause No.</i>	<i>Description</i>	<i>Page No.</i>
	A. GENERAL	
IB.1	Scope of Bid & Source of Funds	6
IB.2	Eligible Bidders	6
IB.3	Cost of Bidding	7
	B. BIDDING DOCUMENTS	
IB.4	Contents of Bidding Documents	7
IB.5	Clarification of Bidding Documents	7
IB.6	Amendment of Bidding Documents	8
	C. PREPARATION OF BID	
IB.7	Language of Bid	8
IB.8	Documents Comprising the Bid	8
IB.9	Sufficiency of Bid	8
IB.10	Bid Prices, Currency of Bid & Payment	9
IB.11	Documents Establishing Bidder's Eligibility and Qualifications	9
IB.12	Documents Establishing Works Conformity to Bidding Documents	9
IB.13	Bidding Security	10
IB.14	Validity of Bids, Format, Signing and Submission of Bid	10
	D-SUBMISSION OF BID	
IB.15	Deadline for Submission, Modification & Withdrawal of Bids	11
	E. BID OPENING AND EVALUATION	
IB.16	Bid Opening, Clarification and Evaluation	12
IB.17	Process to be Confidential	14
	F. AWARD OF CONTRACT	
IB.18	Post Qualification	16
IB.19	Award Criteria & Executive Director (Operation-I), SSWMB Right	16
IB.20	Notification of Award & Signing of Contract Agreement	16
IB.21	Performance Security	16
	Bidding Data	18
	Schedule of Bids	24
	Condition of Contract	32
	Contract Data	47
	Form of Bid Security	50
	Form of Performance Security	53
	Form of Contract Agreement	55
	Bill of Quantity (BoQ)	58
	Drawing	64

INSTRUCTIONS TO BIDDERS

Note: *(These Instructions to Bidders (IB) along with Bidding Data will not be part of Contract and will cease to have effect once the Contract is signed).*

A. GENERAL

IB.1 Scope of Bid & Source of Funds

1.1 Scope of Bid

The Executive Director (Operations-I), Sindh Solid Waste Management Board (SSWMB) as defined in the Bidding Data (hereinafter called - the Procuring Agency wishes to receive Bids for the Works summarized in the Bidding Data (hereinafter referred to as -the Works).

Bidders must quote for the complete scope of work. Any Bid covering partial scope of work will be rejected as non-responsive.

1.2 Source of Funds

Sindh Solid Waste Management Board, Government of Sindh.

IB.2 Eligible Bidders

2.1 Bidding is open to all firms and persons meeting the following requirements:

- a) Duly licensed by the Pakistan Engineering Council (PEC) in the appropriate category for value of works i.e. C-5 or above having codes (CE10).
- b) Information provided in Technical Proposal:-

- (i) Company profile;
- (ii) Works of similar nature and size for each performed in last 3 years;
- (iii) List of Construction equipments;
- (iv) Financial statement of last 3 years;
- (v) Information regarding litigations and abandoned works if any.

IB.3 Cost of Bidding

- 3.1 The bidder shall bear all costs associated with the preparation and submission of its bid and Executive Director (Operations-I), Sindh Solid Waste Management Board will in no case be responsible or liable for those costs, regardless of the conduct or outcome of the bidding process (SPP Rules 24 & 25).

B. BIDDING DOCUMENTS

IB.4 Contents of Bidding Documents

- 4.1 In addition to Invitation for Bids, the Bidding Documents are those stated below, and should be read in conjunction with any Addendum (if issued) in accordance with Sub-Clause IB.6.1.

1. Instructions to Bidders & Bidding Data
2. Form of Bid, Qualification Information & Schedules to Bid Schedules to Bid comprise the following:
 - (i) Schedule A: Schedule of Prices/ Bill of Quantities(BOQ)
 - (ii) Schedule B: Specific Works Data
 - (iii) Schedule C: Works to be performed by subcontractors
 - (iv) Schedule D: Proposed Programme of Works
 - (v) Schedule E: Method of Performing Works
3. Conditions of Contract & Contract Data
4. Standard Forms:
 - (i) Form of Bid Security,
 - (ii) Form of Performance Security;
 - (iii) Form of Contract Agreement;
5. Specifications
6. Drawings, (attached)

IB.5 Clarification of Bidding Documents

- 5.1 A prospective bidder requiring any clarification(s) in respect of the Bidding Documents may notify the Executive Director (Operations-I), Sindh Solid Waste Management Board at the Sindh Solid Waste Management Board address indicated in the Bidding Data.
- 5.2 An interested bidder, who has obtained bidding documents, may request for clarification of contents of bidding documents in writing and Executive Director (Operations-I), Sindh Solid Waste Management Board shall respond to such queries in writing within three calendar days, provided they are received at least five calendar days prior to the date of opening of bid (SPP Rule 23-1).

IB.6 Amendment of Bidding Documents (SPP Rules 22(2) & 22)

- 6.1 At any time prior to the deadline for submission of Bids, the Executive Director (Operations-I), Sindh Solid Waste Management Board may, for any reason, whether at his own initiative or in response to a clarification requested by a interested bidder, modify the Bidding Documents by issuing addendum.
- 6.2 Any addendum thus issued shall be part of the Bidding Documents pursuant to Sub-Clause 6.1 hereof, and shall be communicated in writing to all purchasers of the Bidding Documents. Prospective bidders shall acknowledge receipt of each addendum in writing to the Executive Director (Operations-I), Sindh Solid Waste Management Board.
- 6.3 To afford interested bidders reasonable time in which to take an addendum into account in preparing their Bids, the Executive Director (Operations-I), Sindh Solid Waste Management Board may at its discretion extend the deadline for submission of Bids.

C. PREPARATION OF BIDS

IB.7 Language of Bid

- 7.1 All documents relating to the Bid shall be in the English language in the Contract Data.

IB.8 Documents Comprising the Bid

- 8.1 The Bid submitted by the bidder shall comprise the following:
 - (a) Offer / Covering Letter.
 - (b) Form of Bid duly filled, signed and sealed, in accordance with IB.14.3.
 - (c) Schedules (A to F) to Bid duly filled and initialed, in accordance with the instructions contained therein & in accordance with IB.14.3.
 - (d) Bid Security furnished in accordance with IB.13.
 - (e) Power of Attorney in accordance with IB 14.5.
 - (f) Documentary evidence in accordance with IB.2(c) & IB.11
 - (g) Documentary evidence in accordance with IB.12.

IB.9 Sufficiency of Bid

- 9.1 Each bidder shall satisfy himself before Bidding as to the correctness and sufficiency of his Bid and of the premium on the rates of CSR / rates and prices quoted/entered in the Schedule of Prices, which rates and prices shall except in so far as it is otherwise expressly provided in the Contract, cover all his obligations under the Contract and all matters and things necessary for the proper completion of the works.

- 9.2 The bidder is advised to obtain for himself at his own cost and responsibility all information that may be necessary for preparing the bid and entering into a Contract for execution of the Works.

IB.10 Bid Prices, Currency of Bid and Payment

- 10.1 The bidder shall fill up the Schedule of Prices (Schedule A to Bid) indicating the percentage above or below the Composite Schedule of Rates/unit rates and prices of the Works to be performed under the Contract. Prices in the Schedule of Prices/Bill of Quantities shall be quoted entirely in Pak Rupees keeping in view the instructions contained in the Preamble to Schedule of Prices. For items not covered under Schedule Rates, the prices shall be quoted on Item Rate Basis.
- 10.2 Unless otherwise stipulated in the Conditions of Contract, prices quoted by the bidder shall remain fixed during the bidder's performance of the Contract and not subject to variation on any account.
- 10.3 The unit rates and prices in the Schedule of Prices or percentage above or below on the composite schedule of rates shall be quoted by the bidder in the currency as stipulated in Bidding Data.
- 10.4 Items for which no rate or price is entered by the Bidder will not be paid for by the Procuring Agency when executed and shall be deemed covered by the other rates and prices in the Bill of Quantities.

IB.11 Documents Establishing Bidder's Eligibility and Qualifications

- 11.1 Pursuant to Clause IB.8, the bidder shall furnish, as part of its bid, documents establishing the bidder's eligibility to bid and its qualifications to perform the Contract if its bid is accepted.
- 11.2 Bidder must possess and provide evidence of its capability and the experience as stipulated in Bidding Data and the Qualification Criteria mentioned in the Bidding Documents.

IB.12 Documents Establishing Works' Conformity to Bidding Documents

- 12.1 The documentary evidence of the Works conformity to the Bidding Documents may be in the form of literature, drawings and data and the bidder shall furnish documentation as set out in Bidding Data.
- 12.2 The bidder shall note that standards for workmanship, material and equipment, and references to brand names or catalogue numbers, if any, designated by the Executive Director (Operations-I), Sindh Solid Waste Management Board in the Technical Provisions are intended to be descriptive only and not restrictive.

IB.13 Bid Security

- 13.1 Each bidder shall furnish, as part of his bid, at the option of the bidder, a Bid Security as 2% percentage of the offered bid price in Pak. Rupees in the form of *Deposit at Call/ Payee's Order or a Bank Guarantee* issued by a Scheduled Bank in Pakistan in favour of the Sindh Solid Waste Management Board valid for a period up to twenty eight (28) days beyond the bid validity date.
- 13.2 Any bid not accompanied by an acceptable Bid Security shall be rejected by the Executive Director (Operations-I), Sindh Solid Waste Management Board as non-responsive.
- 13.3 The bid securities of unsuccessful bidders will be returned upon award of contract to the successful bidder or on the expiry of validity of Bid Security whichever is earlier.
- 13.4 The Bid Security of the successful bidder will be returned when the bidder has furnished the required Performance Security, and signed the Contract Agreement (SPP Rule 37).
- 13.5 The Bid Security may be forfeited:
 - (a) If a bidder withdraws his bid during the period of bid validity; or
 - (b) If a bidder does not accept the correction of his Bid Price, pursuant to Sub-Clause 16.4(b) hereof; or
 - (c) In the case of a successful bidder, if he fails within the specified time limit to:
 - (i) Furnish the required Performance Security or
 - (ii) Sign the Contract Agreement.

IB.14 Validity of Bids, Format, Signing and Submission of Bid

- 14.1 Bids shall remain valid for the period of 90 days after the date of bid opening.
- 14.2 In exceptional circumstances, Executive Director (Operations-I), Sindh Solid Waste Management Board may request the bidders to extend the period of validity for a additional period but not exceeding 1/3 of the original period. The request and the bidders responses shall be made in writing or by cable. A Bidder may refuse the request without forfeiting the Bid Security. A Bidder agreeing to the request will not be required or permitted to otherwise modify the Bid, but will be required to extend the validity of Bid Security for the period of the extension, and in compliance with IB.13 in all respects (SPP Rule 38).
- 14.3 All Schedules to Bid are to be properly completed and signed.

- 14.4 No alteration is to be made in the Form of Bid except in filling up the blanks as directed. If any alteration be made or if these instructions be not fully complied with, the bid may be rejected.
- 14.5 Each bidder shall prepare Original and number of copies specified in the Bidding Data of the documents comprising the bid as described in IB.8 and clearly mark them -ORIGINAL and -COPY as appropriate. In the event of discrepancy between them, the original shall prevail.
- 14.6 The original and all copies of the bid shall be typed or written in indelible ink and shall be signed by a person or persons duly authorized to sign (in the case of copies, Photostats are also acceptable). This shall be indicated by submitting a written Power of Attorney authorizing the signatory of the bidder to act for and on behalf of the bidder. All pages of the bid shall be initialed and official seal be affixed by the person or persons signing the bid.
- 14.7 The Bid shall be delivered in person or sent by registered mail at the address to Executive Director (Operations-I), Sindh Solid Waste Management Board as given in Bidding Data.

D. SUBMISSION OF BID

IB.15 Deadline for Submission, Modification & Withdrawal of Bids

- 15.1 Bids must be received by Executive Director (Operations-I), Sindh Solid Waste Management Board at the address/provided in Bidding Data not later than the time and date stipulated therein.
- 15.2 The inner and outer envelopes shall
- (a) be addressed to the Executive Director (Operations-I), Sindh Solid Waste Management Board at the address provided in the Bidding Data;
 - (b) bear the name and identification number of the Contract as defined in the Bidding and Contract Data; and
 - (c) provide a warning not to open before the specified time and date for Bid opening as defined in the Bidding Data.
 - (d) in addition to the identification required in 15.2, the inner envelopes shall indicate the name and address of the Bidder to enable the Bid to be returned unopened in case it is declared late.
 - (e) If the outer envelope is not sealed and marked as above, Executive Director (Operations-I), Sindh Solid Waste Management Board will assume no responsibility for the misplacement or premature opening of the Bid.
- 15.3 Bids submitted through telegraph, telex, fax or e-mail shall not be considered.

- 15.4 Any bid received by Executive Director (Operations-I), Sindh Solid Waste Management Board after the deadline for submission prescribed in Bidding Data will be returned unopened to such bidder.
- 15.5 Any bidder may modify or withdraw his bid after bid submission provided that the modification or written notice of withdrawal is received by the Executive Director (Operations-I), Sindh Solid Waste Management Board prior to the deadline for submission of bids.
- 15.6 Withdrawal of a bid during the interval between the deadline for submission of bids and the expiration of the period of bid validity specified in the Form of Bid may result in forfeiture of the Bid Security pursuant to IB.13.5 (a).

E. BID OPENING AND EVALUATION

IB.16 Bid Opening, Clarification and Evaluation (SPP Rules 41, 42 & 43)

- 16.1 Procurement Committee constituted by Sindh Solid Waste Management Board will open the bids, in the presence of bidders representatives who choose to attend, on 19th September, 2016 at 03:30 PM in the Committee Room of SSWMB.
- 16.2 The bidder's name, Bid Prices, any discount, the presence or absence of Bid Security, and such other details as the Procurement Committee, Sindh Solid Waste Management Board at its discretion may consider appropriate, will be announced by the Procurement Committee at the bid opening. Secretary, Procurement Committee, Sindh Solid Waste Management Board will record the minutes of the bid opening. Representatives of the bidders who choose to attend shall sign the attendance sheet.

Any Bid Price or discount which is not read out and recorded at bid opening will not be taken into account in the evaluation of bid.
- 16.3 To assist in the examination, evaluation and comparison of Bids the Procurement Committee may, at its discretion, ask the bidder for a clarification of its Bid. The request for clarification and the response shall be in writing and no change in the price or substance of the Bid shall be sought, offered or permitted (SPP Rule 43).
- 16.4 (a) Prior to the detailed evaluation, pursuant to IB.16.7 to 16.9, the Procurement Committee will determine the substantial responsiveness of each bid to the Bidding Documents. For purpose of these instructions, a substantially responsive bid is one, which conforms to all the terms and conditions of the Bidding Documents without material deviations. It will include determining the requirements listed in Bidding Data.

(b) Arithmetical errors will be rectified on the following basis:

If there is a discrepancy between the unit price and total price that is obtained by multiplying the unit price and quantity, the unit price shall prevail and the total price shall be corrected. If there is a discrepancy between the words and figures the amount in words shall prevail. If there is a discrepancy between the Total Bid price entered in Form of Bid and the total shown in Schedule of Prices-Summary, the amount stated in the Form of Bid will be corrected by the Executive Director (Operations-I), Sindh Solid Waste Management Board in accordance with the Corrected Schedule of Prices.

If the bidder does not accept the corrected amount of Bid, his Bid will be rejected and his Bid Security forfeited.

16.5 A Bid determined as substantially non-responsive will be rejected and will not subsequently be made responsive by the bidder by correction of the non-conformity.

16.6 Any minor informality or non-conformity or irregularity in a Bid which does not constitute a material deviation (**major deviation**) may be waived by Executive Director (Operations-I), Sindh Solid Waste Management Board provided such waiver does not prejudice or affect the relative ranking of any other bidders.

(A). Major (material) Deviations include:-

- (i) has been not properly signed;
- (ii) is not accompanied by the bid security of required amount and manner;
- (iii) stipulating price adjustment when fixed price bids were called for;
- (iv) failing to respond to specifications;
- (v) failing to comply with Mile-stones/Critical dates provided in Bidding Documents;
- (vi) sub-contracting contrary to the Conditions of Contract specified in Bidding Documents;
- (vii) refusing to bear important responsibilities and liabilities allocated in the Bidding Documents, such as performance guarantees and insurance coverage;
- (viii) taking exception to critical provisions such as applicable law, taxes and duties and dispute resolution procedures;
- (ix) a material deviation or reservation is one :
 - (a) which affect in any substantial way the scope, quality or performance of the works;
 - (b) adoption/rectification whereof would affect unfairly the competitive position of other bidders presenting substantially responsive bids.

(B) Minor Deviations

Bids that offer deviations acceptable to the Sindh Solid Waste Management Board and which can be assigned a monetary value may be considered substantially responsive at least as to the issue of fairness. This value would however be added as an adjustment for evaluation purposes only during the detailed evaluation process.

16.7 The Procurement Committee constituted by Sindh Solid Waste Management Board will evaluate and compare only the bids previously determined to be substantially responsive pursuant to IB.16.4 to 16.6 as per requirements given hereunder. Bids will be evaluated for complete scope of works. The prices will be compared on the basis of the Evaluated Bid Price pursuant to IB.16.8 herein below.

16.8 Technical Evaluation: It will be examined in detail whether the works offered by the bidder complies with the Technical Provisions of the Bidding Documents. For this purpose, the bidder's data submitted with the bid in Schedule B to Bid will be compared with technical features/criteria of the works detailed in the Technical Provisions. Other technical information submitted with the bid regarding the Scope of Work will also be reviewed. In evaluating the bids, the Director (GTS) / Engineer / Executive Director (Operations-I), Sindh Solid Waste Management Board shall determine for each bid in addition to the Bid Price, the following factors (adjustments) in the manner and to the extent indicated below to determine the Evaluated Bid Price:

- (i) making any correction for arithmetic errors pursuant to IB.16.4 hereof
- (ii) discount, if any, offered by the bidders as also read out and recorded at the time of bid opening.
- (iii) excluding **provisional sums** and the provisions for **contingencies** in the Bill of Quantities **if any**, but including **Day work**, where priced competitively.

IB.17 Process to be Confidential

17.1 Subject to IB.16.3 heretofore, no bidder shall contact any officer / official of Sindh Solid Waste Management Board on any matter relating to its Bid from the time of the Bid opening to the time the bid evaluation result is announced by the Procurement Committee, Sindh Solid Waste Management Board. The evaluation result shall be announced at least seven (07) days prior to award of Contract (SPP Rule 45). The announcement to all bidders will include table(s) comprising read out prices, discounted prices, price adjustments made, final evaluated prices and recommendations against all the bids evaluated.

- 17.2 Any effort by a bidder to influence Director (GTS) / Engineer/ Executive Director (Operations-I), Sindh Solid Waste Management Board in the Bid evaluation, Bid comparison or Contract Award decisions may result in the rejection of his Bid. Whereas any bidder feeling aggrieved, may lodge a written complaint to Complaint Redressal Committee as per terms and conditions mentioned in SPP Rules 31 & 32. However, mere fact of lodging a complaint shall not warrant suspension of procurement process.
- 17.3 Bidders may be excluded if involved in **“Corrupt and Fraudulent Practices”** means either one or any combination of the practices given below SPP Rule2(q);
- (i) **“Coercive Practice”** means any impairing or harming, or threatening to impair or harm, directly or indirectly, any party or the property of the party to influence the actions of a party to achieve a wrongful gain or to cause a wrongful loss to another party;
 - (ii) **“Collusive Practice”** means any arrangement between two or more parties to the procurement process or contract execution, designed to achieve with or without the knowledge of Sindh Solid Waste Management Board authorities to establish prices at artificial, noncompetitive levels for any wrongful gain;
 - (iii) **“Corrupt Practice”** means the offering, giving, receiving or soliciting, directly or indirectly, of anything of value to influence the acts of another party for wrongful gain;
 - (iv) **“Fraudulent Practice”** means any act or omission, including a misrepresentation, that knowingly or recklessly misleads, or attempts to mislead, a party to obtain a financial or other benefit or to avoid an obligation;
 - (v) **“Obstructive Practice”** means harming or threatening to harm, directly or indirectly, persons or their property to influence their participation in a procurement process, or affect the execution of a contract or deliberately destroying, falsifying, altering or concealing of evidence material to the investigation or making false statements before investigators in order to materially impede an investigation into allegations of a corrupt, fraudulent, coercive or collusive practice; or threatening, harassing or intimidating any party to prevent it from disclosing its knowledge of matters relevant to the investigation or from pursuing the investigation, or acts intended to materially impede the exercise of inspection and audit rights provided for under the Rules.

F. AWARD OF CONTRACT

IB.18. Post Qualification

18.1 The Executive Director (Operations-I), Sindh Solid Waste Management Board at any stage of the bid evaluation, having credible reasons for or *prima facie* evidence of any defect in contractor's capacities, may require the contractors to provide information concerning their professional, technical, financial, legal or managerial competence whether already pre-qualified or not:

Provided, that such qualification shall only be laid down after recording reasons therefore in writing. They shall form part of the records of that bid evaluation report.

18.2 The determination will take into account the bidder's financial and technical capabilities. It will be based upon an examination of the documentary evidence of the bidders qualifications submitted under B.11, as well as such other information required in the Bidding Documents.

IB.19. Award Criteria & Executive Director (Operations-I), Sindh Solid Waste Management Board Right

19.1 Subject to IB.19.2, the Procuring Agency i.e. Sindh Solid Waste Management Board shall award the Contract to the bidder whose bid has been determined to be substantially responsive to the Bidding Documents and who has offered the lowest evaluated Bid Price, provided that such bidder has been determined to be qualified to satisfactory perform the Contract in accordance with the provisions of the IB.18.

19.2 Notwithstanding IB.19.1, the Procuring Agency i.e. Sindh Solid Waste Management Board reserves the right to accept or reject any bid, and to annul the bidding process and reject all bids, at any time prior to award of Contract, without thereby incurring any liability to the affected bidders or any obligation to inform the affected bidders of the grounds for the Executive Director (Operations-I), Sindh Solid Waste Management Board action except that the grounds for its rejection of all bids shall upon request be communicated, to any bidder who submitted a bid, without justification of the grounds. Notice of the rejection of all the bids shall be given promptly to all the bidders (SPP Rule 25).

IB.20 Notification of Award & Signing of Contract Agreement

- 20.1 Prior to expiration of the period of bid validity prescribed by the Executive Director (Operations-I), Sindh Solid Waste Management Board, the Executive Director (Operations-I), Sindh Solid Waste Management Board will notify the successful bidder in writing (-Letter of Acceptance) that his bid has been accepted (SPP Rule 49).
- 20.2 Within seven (07) days from the date of furnishing of acceptable Performance Security under the Conditions of Contract, Executive Director (Operations-I), Sindh Solid Waste Management Board will send the successful bidder the Form of Contract Agreement provided in the Bidding Documents, incorporating all agreements between the parties.
- 20.3 The formal Agreement between the Executive Director (Operations-I), Sindh Solid Waste Management Board and the successful bidder duly stamped at rate of 0.3% of bid price (updated from time to time) stated in Letter of Acceptance shall be executed within seven (07) days of the receipt of Form of Contract Agreement by the successful bidder from the Executive Director (Operations-I), Sindh Solid Waste Management Board.

IB.21 Performance Security

- 21.1 The successful bidder shall furnish to the Executive Director (Operations-I), Sindh Solid Waste Management Board a Performance Security **2%** of total bid in the form of Pay Order / Bank Draft in favour of Sindh Solid Waste Management Board should reach in office of the **Assistant Director (Finance)**, Sindh Solid Waste Management Board, Government of Sindh, Bungalow# 13, Al Hamra Housing Society, Shaheed e Millat Road, Karachi in form and the amount stipulated in the Conditions of Contract within a period of fourteen (14) days after the receipt of Letter of Acceptance (SPP Rule 39).
- 21.2 Failure of the successful bidder to comply with the requirements of Sub-Clauses IB.20.2 & 20.3 or 21.1 or Clause IB.22 shall constitute sufficient grounds for the annulment of the award and forfeiture of the Bid Security.
- 21.3 Publication of Award of Contract: within seven days of the award of contract, the procuring shall publish on the website of the authority and on its own website, if such a website exists, the results of the bidding process, identifying the bid through procurement identifying Number if any and the following information:
 - (1) Evaluation Report;
 - (2) Form of Contract and letter of Award;
 - (3) Bill of Quantities or Schedule of Requirements. (SPP Rule 50)

BIDDING DATA

(The following specific data for the works to be tendered shall complement, amend, or supplement the provisions in the Instructions to Bidders. Wherever there is a conflict, the provisions herein shall prevail over those in the Instructions to Bidders).

Instruction to Bidders

Clause Reference

1.1 Name of Procuring Agency

Sindh Solid Waste Management Board

Brief Description of Works:

“Construction of Boundary Wall on different Sites of GTS at Karachi (Civil Works)”

(a) Procuring Agency address:

Executive Director (Operations-I), Sindh Solid Waste Management Board
Bungalow# 13, Al Hamra, Housing Society, Shaheed E Millat Road, Karachi
Ph: +92 21 9933 3706-7
Fax: +92 21 9933 3700
Email: info@sswmb.gos.pk
Website: www.sswmb.gos.pk

(b) Director (GTS) / Engineer’s address:

Director (GTS), Sindh Solid Waste Management Board
Bungalow# 13, Al Hamra, Housing Society, Shaheed E Millat Road, Karachi
Ph: +92 21 9933 3706-7
Fax: +92 21 9933 3700
Email: info@sswmb.gos.pk

10.3 Bid shall be quoted entirely in Pak. Rupees. The payment shall be made in Pak. Rupees.

11.2 The bidder has the financial, technical and constructional capability necessary to perform the Contract as follows:

i. Financial capacity:

(must have turnover of Rs. 50 Million or above);

ii. Technical capacity:

PEC Category C-5 or above having codes (CE10).

One B.E Civil with 15 years’ experience.

One DAE Civil with 10 years’ experience.

One DAE Civil with 05 years’ experience.

iii. Construction Capacity:

1 Mixer, 1 Tractor, 1 Dumper, 1 Compactor & three pair of each basic equipment.

12.1 (a) A detailed description of the Works, essential technical and performance characteristics.

(b) Complete set of technical information, description data, literature and drawings as required in accordance with Schedule B to Bid, Specific Works Data. This will include but not be limited to a sufficient number of drawings, photographs, catalogues, illustrations and such other information as is necessary to illustrate clearly the significant characteristics such as general construction dimensions and other relevant information about the works to be performed.

13.1 Amount of Bid Security

2% of the bid amount

14.1 Period of Bid Validity

90 days

14.4 Number of Copies of the Bid to be submitted:

One original plus One Copy

14.6 (a) Procuring Agency Address for the Purpose of Bid Submission

Executive Director (Operations-I), Sindh Solid Waste Management Board
Bungalow# 13, Al Hamra, Housing Society, Shaheed E Millat Road, Karachi

15.1 Deadline for Submission of Bids

26th December, 2017 Latest by 03:00 PM

16.1 Venue, Time, and Date of Bid Opening

Venue: Committee Room, Sindh Solid Waste Management Board,
Bungalow# 13, Al Hamra, Housing Society, Shaheed E Millat Road, Karachi

26th December, 2016 at 03:30 PM

Responsiveness of Bids

- (i) Bid is valid till required period,
- *(ii) This is a Fixed Price Contract, Bid prices are firm during currency of contract/Price adjustment and no escalation of price shall be allowed;
- (iii) Completion period offered is within specified limits,
- (iv) Bidder is eligible to Bid and possesses the requisite experience, capability and qualification.
- (v) Bid does not deviate from basic technical requirements and
- (vi) Bids are generally in order, etc.

FORM OF BID AND SCHEDULES TO BID

FORM OF BID
(LETTER OF OFFER)

Bid Reference SSWMB/NIT-9/2017-18

Construction of Boundary Wall on different Sites of GTS at
Karachi (Civil Works)

The Executive Director (Operation-I),
Sindh Solid Waste Management Board,
Karachi

Dear Sir,

1. Having examined the Bidding Documents including Instructions to Bidders, Bidding Data, Conditions of Contract, Contract Data, Specifications, Drawings, if any, Schedule of Prices and Addenda Nos. ____ for the execution of the above-named works, we, the undersigned, being a company doing business under the name of and address

_____ and being duly incorporated under the laws of Pakistan hereby offer to execute and complete such works and remedy any defects therein in conformity with the said Documents including Addenda thereto for the Total Bid Price of Rs _____ (Rupees _____) or such other sum as may be ascertained in accordance with the said Documents.

2. We understand that all the Schedules attached hereto form part of this Bid.
3. As security for due performance of the undertakings and obligations of this Bid, we submit herewith a Bid Security in the amount of Rs. _____ (Rupees _____) drawn in your favour or made payable to you and valid for a period of twenty eight (28) days beyond the period of validity of Bid.
4. We undertake, if our Bid is accepted, to commence the Works and to deliver and complete the Works comprised in the Contract within the time(s) stated in Contract Data.
5. We agree to abide by this Bid for the period of 120 days from the date fixed for receiving the same and it shall remain binding upon us and may be accepted at any time before the expiration of that period.
6. Unless and until a formal Agreement is prepared and executed, this Bid, together with your written acceptance thereof, shall constitute a binding contract between us.
7. We undertake, if our Bid is accepted, to execute the Performance Security referred to in Conditions of Contract for the due performance of the

Executive Director (Operation-I)

Contractor

Contract.

8. We understand that you are not bound to accept the lowest or any bid you may receive.
9. We do hereby declare that the Bid is made without any collusion, comparison of figures or arrangement with any other person or persons making a bid for the Works.

Dated this _____ day of _____, 20

Signature _____

in the capacity of _____ duly authorized to sign bid for and on behalf of

(Name of Bidder in Block Capitals)

(Seal)

Address _____

Witness:

(Signature) _____

Name: _____

Address: _____

SCHEDULES TO BID INCLUDE THE FOLLOWING:

Items			Page No.
•	Schedule A	to Bid: Schedule of Prices	25-26
•	Schedule B	to Bid: Specific Works Data	27
•	Schedule C	to Bid: Works to be Pe rformed by Subcontractors	28
•	Schedule D	to Bid: Proposed Program of Works	29
•	Schedule E	to Bid: Method of Performing Works	30
•	Schedule F	to Bid: Integrity Pact	31

Preamble to Schedule of Prices

1. General

- 1.1 The Schedule of Prices shall be read in conjunction with the Conditions of Contract, Contract Data together with the Specifications and Drawings, if any.
- 1.2 The Contract shall be for the whole of the works as described in these Bidding Documents. Bids must be for the complete scope of works.

2. Description

- 2.1 The general directions and descriptions of works and materials are not necessarily repeated nor summarized in the Schedule of Prices. References to the relevant sections of the Bidding Documents shall be made before entering prices against each item in the Schedule of Prices.

3. Units & Abbreviations

- 3.1 Units of measurement, symbols and abbreviations expressed in the Bidding Documents shall comply with the System International Unites (SI Units).
As per Government of Sindh

4. Rates and Prices

- 4.1 Except as otherwise expressly provided under the Conditions of Contract, the rates and amounts entered in the Schedule of Prices shall be the rates at which the Contractor shall be paid and shall be the full inclusive value of the works set forth or implied in the Contract; except for the amounts reimbursable, if any to the Contractor under the Contract.
- 4.2 Unless otherwise stipulated in the Contract Data, the premium, rates and prices entered by the bidder shall not be subject to adjustment during the performance of the Contract.
- 4.3 All duties, taxes and other levies payable by the Contractor shall be included in the rates and prices.
- 4.4 The whole cost of complying with the provisions of the Contract shall be included in the items provided in the Schedule of Prices, and where no items are provided, the cost shall be deemed to be distributed among the rates and prices entered for the related

items of the Works and no separate payment will be made for those items. The rates, prices and amounts shall be entered against each item in the Schedule of Prices. Any item against which no rate or price is entered by the bidder will not be paid for by the Sindh Solid Waste Management Board when executed and shall be deemed covered by the rates and prices for other items in the Schedule of Prices.

- 4.5 (a) The bidder shall be deemed to have obtained all information as to and all requirements related thereto which may affect the bid price.
- * (b) The Contractor shall be responsible to make complete arrangements for the transportation of the Plant to the Site.
- 4.6 The Contractor shall provide for all parts of the Works to be completed in every respect. Notwithstanding that any details, accessories, etc. required for the complete installation and satisfactory operation of the Works, are not specifically mentioned in the Specifications, such details shall be considered as included in the Contract Price.

5. Bid Prices

5.1 Break-up of Bid Prices

The various elements of Bid Prices shall be quoted as detailed by the Procuring Agency in the format of Schedule of Prices.

The bidder shall recognize such elements of the costs, which he expects to incur the performance of the Works, and shall include all such costs in the rates and amounts entered in the Schedule of Prices.

5.2 Total Bid Price

The total of bid prices in the Schedule of Prices shall be entered in the Summary of Bid Prices.

6. Provisional Sums and Day work

- 6.1 Provisional Sums included and so designated in the Schedule of Prices if any, shall be expended in whole or in part at the direction and discretion of the Director (GTS) / Engineer / Executive Director (Operations-I), Sindh Solid Waste Management Board. The Contractor will only receive payment in respect of Provisional Sums, if he has been instructed by the Director (GTS) / Engineer / Executive Director (Operations-I), Sindh Solid Waste Management Board to utilize such sums.
- 6.2 Day work rates in the contractor's bid are to be used for small additional amounts of work and only when the Director (GTS) / Engineer have given written instructions in advance for additional work to be paid for in that way.

***SPECIFIC WORKS DATA**

Work will be itemized work based on Sindh Schedule and each item whether linked to other item or not for execution will be considered as one work.

1. Organization Chart indicating head office and field office personnel involved in management and supervision, engineering, equipment maintenance and purchasing.
2. Mobilization in Pakistan, the type of facilities including personnel accommodation, office accommodation, provision for maintenance and for storage, communications, security and other services to be used.
3. The method of executing the Works, the procedures for installation of equipment and machinery and transportation of equipment and materials to the site.

WORKS TO BE PERFORMED BY SUBCONTRACTORS*

The bidder will do the work with his own forces except the work listed below which he intends to sub-contract.

Items of Works to be Sub-Contracted	Name and address of Sub-Contractors	Statement of similar works previously executed. (<i>attach evidence</i>)
-------------------------------------	-------------------------------------	--

The work shall not be sublet to sub-contractor

1. No change of Sub-Contractors shall be made by the bidder without prior approval of the Executive Director (Operations-I), Sindh Solid Waste Management Board.
2. The truthfulness and accuracy of the statement as to the experience of Sub-Contractors is guaranteed by the bidder. The Executive Director (Operations-I), Sindh Solid Waste Management Board's judgment shall be final as to the evaluation of the experience of Sub-Contractors submitted by the bidder.
3. Statement of similar works shall include description, location & value of works, year completed and name & address of the clients.

PROPOSED PROGRAMME OF WORKS

Bidder shall provide a programme in a bar chart or Program Evaluation and Review Technique (PERT) or Critical Path Method (CPM) showing the sequence of work items by which he proposes to complete the works of the entire Contract. The programme should indicate the sequence of work items and the period of time during which he proposes to complete the works including the activities like designing, schedule of submittal of drawings, ordering and procurement of materials, manufacturing, delivering, construction of civil works, erection, testing and commissioning of works to be supplied under the Contract.

METHOD OF PERFORMING WORKS

The bidder is required to submit a narrative outlining the method of performing the Works. The narrative should indicate in detail and include but not be limited to:

- The sequence and methods in which he proposes to carry out the Works, including the number of shifts per day and hours per shift, he expects to work.
- A list of all major items of construction and plant erection, tools and vehicles proposed to be used in delivering/carrying out the works at site.
- The procedure for installation of equipment and transportation of equipment and materials to the site.
- Organization chart indicating head office & field office personnel involved in management, supervision and engineering of the Works to be done under the Contract.

SCHEDULE - F TO BID

(INTEGRITY PACT)

**DECLARATION OF FEES, COMMISSION AND BROKERAGE ETC
PAYABLE BY CONTRACTORS
(FOR CONTRACTS WORTH RS. 10.00 MILLION OR MORE)**

Contract No. _____ Dated _____
Contract Value: _____
Contract Title: _____

..... [name of Contractor] hereby declares that it has not obtained or induced the procurement of any contract, right, interest, privilege or other obligation or benefit from Government of Sindh (GoS) or any administrative subdivision or agency thereof or any other entity owned or controlled by it (GoS) through any corrupt business practice.

Without limiting the generality of the foregoing, [name of Contractor] represents and warrants that it has fully declared the brokerage, commission, fees etc. paid or payable to anyone and not given or agreed to give and shall not give or agree to give to anyone within or outside Pakistan either directly or indirectly through any natural or juridical person, including its affiliate, agent, associate, broker, consultant, director, promoter, shareholder, sponsor or subsidiary, any commission, gratification, bribe, finder's fee or kickback, whether described as consultation fee or otherwise, with the object of obtaining or inducing the procurement of a contract, right, interest, privilege or other obligation or benefit in whatsoever form from, from Procuring Agency (PA) except that which has been expressly declared pursuant hereto.

[name of Contractor] accepts full responsibility and strict liability that it has made and will make full disclosure of all agreements and arrangements with all persons in respect of or related to the transaction with PA and has not taken any action or will not take any action to circumvent the above declaration, representation or warranty.

[name of Contractor] accepts full responsibility and strict liability for making any false declaration, not making full disclosure, misrepresenting facts or taking any action likely to defeat the purpose of this declaration, representation and warranty. It agrees that any contract, right, interest, privilege or other obligation or benefit obtained or procured as aforesaid shall, without prejudice to any other rights and remedies available to PA under any law, contract or other instrument, be voidable at the option of PA.

Notwithstanding any rights and remedies exercised by PA in this regard, [name of Supplier/Contractor/Consultant] agrees to indemnify PA for any loss or damage incurred by it on account of its corrupt business practices and further pay compensation to PA in an amount equivalent to ten times the sum of any commission, gratification, bribe, finder's fee or kickback given by [name of Contractor] as aforesaid for the purpose of obtaining or inducing the procurement of any contract, right, interest, privilege or other obligation or benefit in whatsoever form from PA.

.....
[Procuring Agency]

[Contractor]

CONDITIONS OF CONTRACT

CONDITIONS OF CONTRACT

1. GENERAL PROVISIONS

1.1 Definitions

In the Contract as defined below, the words and expressions defined shall have the following meanings assigned to them, except where the context requires otherwise:

The Contract

- 1.1.1 "Contract" means the Contract Agreement and the other documents listed in the Contract Data.
- 1.1.2 "Specifications" means the document as listed in the Contract Data, including Executive Director (Operations-I), Sindh Solid Waste Management Board requirements in respect of design to be carried out by the Contractor (if any), and any Variation to such document.
- 1.1.3 "Drawings" means the Executive Director (Operations-I), Sindh Solid Waste Management Board drawings of the Works as listed in the Contract Data, and any Variation to such drawings.

Persons

- 1.1.4 "Executive Director (Operations-I)", Sindh Solid Waste Management Board means the person named in the Contract Data and the legal successors in title to this person, but not (except with the consent of the Contractor) any assignee.
- 1.1.5 "Contractor" means the person named in the Contract Data and the legal successors in title to this person, but not (except with the consent of the Executive Director (Operations-I), Sindh Solid Waste Management Board) any assignee.
- 1.1.6 "Party" means the Executive Director (Operations-I), Sindh Solid Waste Management Board or the Contractor.

Dates, Times and Periods

- 1.1.7 "Commencement Date" means the date fourteen (14) days after the date the Contract comes into effect or any other date named in the Contract Data.
- 1.1.8 "Day" means a calendar day
- 1.1.9 "Time" for Completion means the time for completing the Works as stated in the Contract Data (or as extended under Sub-Clause 7.3), calculated from the Commencement Date.

Money and Payments

- 1.1.10 "Cost" means all expenditure properly incurred (or to be incurred) by the Contractor, whether on or off the Site, including

overheads and similar charges but does not include any allowance for profit.

Other Definitions

- 1.1.11 "Contractor's Equipment" means all machinery, apparatus and other things required for the execution of the Works but does not include Materials or Plant intended to form part of the Works.
- 1.1.12 "Country" means the Islamic Republic of Pakistan.
- 1.1.13 "Executive Director (Operations-I), Sindh Solid Waste Management Board Risks" means those matters listed in Sub-Clause 6.1.
- 1.1.14 "Force Majeure" means an event or circumstance which makes performance of a Party's obligations illegal or impracticable and which is beyond that Party's reasonable control.
- 1.1.15 "Materials" means things of all kinds (other than Plant) to be supplied and incorporated in the Works by the Contractor.
- 1.1.16 "Plant" means the machinery and apparatus intended to form or forming part of the Works.
- 1.1.17 "Site" means the places provided by the Executive Director (Operations-I), Sindh Solid Waste Management Board where the Works are to be executed, and any other places specified in the Contract as forming part of the Site.
- 1.1.18 "Variation" means a change which is instructed by the Director (GTS) / Engineer/ Executive Director (Operations-I), Sindh Solid Waste Management Board under Sub-Clause 10.1.
- 1.1.19 "Works" means any or all the works whether Supply, Installation, Construction etc. and design (if any) to be performed by the Contractor including temporary works and any variation thereof.
- 1.1.20 "Director (GTS) / Engineer" means the person notified by the Executive Director (Operations-I), Sindh Solid Waste Management Board to act as Director (GTS) / Engineer for the purpose of the Contract and named as such in Contract Data.

1.2 Interpretation

Words importing persons or parties shall include firms and organizations. Words importing singular or one gender shall include plural or the other gender where the context requires.

1.3 Priority of Documents

The documents forming the Contract are to be taken as mutually explanatory of one another. If an ambiguity or discrepancy is found in the

documents, the priority of the documents shall be in accordance with the order as listed in the Contract Data.

1.4 Law

The law of the Contract is the relevant Law of Islamic Republic of Pakistan.

1.5 Communications

All Communications related to the Contract shall be in English language.

1.6 Statutory Obligations

The Contractor shall comply with the Laws of Islamic Republic of Pakistan and shall give all notices and pay all fees and other charges in respect of the Works.

**2. THE EXECUTIVE DIRECTOR (Operations-I),
SINDH SOLID WASTAGE MANAGEMENT BOARD**

2.1 Provision of Site

The Executive Director (Operations-I), Sindh Solid Waste Management Board shall provide the Site and right of access thereto at the times stated in the Contract Data.

Site Investigation Reports are those that were included in the bidding documents and are factual and interpretative reports about the surface and subsurface conditions at the Site.

2.2 Permits etc.

The Executive Director (Operations-I), Sindh Solid Waste Management Board shall, if requested by the Contractor, assist him in applying for permits, licenses or approvals which are required for the Works.

2.3 Director (GTS) / Engineer's/ Executive Director (Operations-I), Sindh Solid Waste Management Board's Instructions

The Contractor shall comply with all instructions given by the Executive Director (Operations-I), Sindh Solid Waste Management Board or the Director (GTS) / Engineer, if notified by the Executive Director (Operations-I), Sindh Solid Waste Management Board in respect of the Works including the suspension of all or part of the works.

2.4 Approvals

No approval or consent or absence of comment by the Executive Director (Operations-I), Sindh Solid Waste Management Board shall affect the Contractor's obligations.

3. DIRECTOR (GTS) / ENGINEER'S/ EXECUTIVE DIRECTOR (Operations-I), SINDH SOLID WASTAGE MANAGEMENT BOARD 'S REPRESENTATIVES

3.1 Authorized Person

The Executive Director (Operations-I), Sindh Solid Waste Management Board shall appoint a duly authorized person to act for him and on his behalf for the purposes of this Contract. Such authorized person shall be duly identified in the Contract Data or otherwise notified in writing to the Contractor as soon as he is so appointed. In either case the Executive Director (Operations-I), Sindh Solid Waste Management Board shall notify the Contractor, in writing, the precise scope of the authority of such authorized person at the time of his appointment.

3.2 Director (GTS) / Engineer's/ Executive Director (Operations-I), Sindh Solid Waste Management Board Representative

The name and address of Director (GTS) / Engineer's/ Executive Director (Operations-I), Sindh Solid Waste Management Board's Representative is given in Contract Data. However the Contractor shall be notified by the Director (GTS) / Engineer/ Executive Director (Operations-I), Sindh Solid Waste Management Board the delegated duties and authority before the Commencement of works.

4. THE CONTRACTOR

4.1 General Obligations

The Contractor shall carry out the works properly and in accordance with the Contract. The Contractor shall provide all supervision, labour, Materials, Plant and Contractor's Equipment which may be required.

4.2 Contractor's Representative

The Contractor shall appoint a representative at site on full time basis to supervise the execution of work and to receive instructions on behalf of the Contractor but only after obtaining the consent of the Executive Director (Operations-I), Sindh Solid Waste Management Board for such appointment which consent shall not be withheld without plausible reason(s) by the Executive Director (Operations-I), Sindh Solid Waste Management Board. Such authorized representative may be substituted / replaced by the Contractor at any time during the Contract Period but only after obtaining the consent of the Executive Director (Operations-I), Sindh Solid Waste Management Board as aforesaid.

4.3 Subcontracting

The Contractor shall not subcontract the whole of the works. The Contractor shall not subcontract any part of the works without the consent of the Executive Director (Operations-I), Sindh Solid Waste Management Board.

4.4 Performance Security

The Contractor shall furnish to the Executive Director (Operations-I), Sindh Solid Waste Management Board within fourteen (14) days after receipt of Letter of Acceptance a Performance Security at the option of the bidder, in the form of Payee's order /Bank Draft or Bank Guarantee from scheduled bank for the amount and validity specified in Contract Data.

5. DESIGN BY CONTRACTOR

1.1 Not Applicable

5.2 Responsibility for Design

The Contractor shall remain responsible for his bided design and the design under this Clause, both of which shall be fit for the intended purposes defined in the Contract and he shall also remain responsible for any infringement of any patent or copyright in respect of the same. The Director (GTS) / Engineer/ Executive Director (Operations-I), Sindh Solid Waste Management Board shall be responsible for the Specifications and Drawings.

6. EXECUTIVE DIRECTOR (Operations-I), SINDH SOLID WASTAGE MANAGEMENT BOARD'S RISKS.

1.1 The Executive Director (Operations-I), Sindh Solid Waste Management Board
The Executive Director (Operations-I), Sindh Solid Waste Management Board's Risks are:-

- a) War, hostilities (whether war be declared or not), invasion, act of foreign enemies, within the Country;
- b) Rebellion, terrorism, revolution, insurrection, military or usurped power, or civil war, within the Country;
- c) Riot, commotion or disorder by persons other than the Contractor's personnel and other employees including the personnel and employees of Sub-Contractors, affecting the Site and/or the Works;
- d) Ionizing radiations, or contamination by radio-activity from any nuclear fuel, or from any nuclear waste from the combustion of nuclear fuel, radio-active toxic explosive, or other hazardous properties of any explosive nuclear assembly or nuclear component of such an assembly, except to the extent to which the Contractor/Sub-Contractors may be responsible for the use of any radio-active material;
- e) Pressure waves caused by aircraft or other aerial devices travelling at sonic or supersonic speeds;
- f) Use or occupation by the Executive Director (Operations-I), Sindh Solid Waste Management Board of any part of the Works, except as may be specified in the Contract;

- g) Late handing over of sites, anomalies in drawings, late delivery of designs and drawings of any part of the Works by the Executive Director (Operations-I), Sindh Solid Waste Management Board's personnel or by others for whom the Executive Director (Operations-I), Sindh Solid Waste Management Board is responsible;
- h) A suspension under Sub-Clause 2.3 unless it is attributable to the Contractor's failure; and
- i) Physical obstructions or physical conditions other than climatic conditions, encountered on the Site during the performance of the Works, for which the Contractor immediately notified to the Executive Director (Operations-I), Sindh Solid Waste Management Board and accepted by the Executive Director (Operations-I), Sindh Solid Waste Management Board.

7. TIME FOR COMPLETION

7.1 Execution of the Works

The Contractor shall commence the Works on the Commencement Date and shall proceed expeditiously and without delay and shall complete the Works, subject to Sub-Clause 7.3 below, within the Time for Completion.

7.2 Programme

Within the time stated in the Contract Data, the Contractor shall submit to the Director (GTS) / Engineer/ Executive Director (Operations-I), Sindh Solid Waste Management Board a programme for the Works in the form stated in the Contract Data.

7.3 Extension of Time

The Contractor shall, within such time as may be reasonable under the circumstances, notify the Executive Director (Operations-I), Sindh Solid Waste Management Board /Director (GTS) / Engineer of any event(s) falling within the scope of Sub-Clause 6.1 or 10.3 of these Conditions of Contract and request the Director (GTS) / Engineer for a reasonable extension in the time for the completion of works. Subject to the aforesaid, the Director (GTS) / Engineer shall determine such reasonable extension in the time for the completion of works as may be justified in the light of the details/particulars supplied by the Contractor in connection with the such determination by the Director (GTS) / Engineer within such period as may be prescribed by the Director (GTS) / Engineer for the same; and the Director (GTS) / Engineer may extend the time for completion as determined.

7.4 Late Completion

If the Contractor fails to complete the Works within the Time for Completion, the Contractor's only liability to the Executive Director (Operations-I), Sindh Solid Waste Management Board for such failure shall be to pay the amount as **liquidity damages** stated in the Contract Data for each day for which he fails to complete the Works.

8. TAKING-OVER

8.1 Completion

The Contractor may notify the Director (GTS) / Engineer/ Executive Director (Operations-I), Sindh Solid Waste Management Board when he considers that the Works are complete.

8.2 Taking-Over Notice

Within fourteen (14) days of the receipt of the said notice of completion from the Contractor the Director (GTS) / Engineer shall either takeover the completed works and issue a Certificate of Completion to that effect or shall notify the Contractor his reasons for not taking-over the works. While issuing the Certificate of Completion as aforesaid, the Director (GTS) / Engineer may identify any outstanding items of work which the Contractor shall undertake during the Maintenance Period.

9. REMEDYING DEFECTS

9.1 Remedying Defects

The Contractor shall for a period stated in the Contract Data from the date of issue of the Certificate of Completion carry out, at no cost to the Executive Director (Operations-I), Sindh Solid Waste Management Board, repair and rectification work which is necessitated by the earlier execution of poor quality of work or use of below specifications material in the execution of Works and which is so identified by the Executive Director (Operations-I), Sindh Solid Waste Management Board /Director (GTS) / Engineer in writing within the said period. Upon expiry of the said period, and subject to the Contractor's faithfully performing his aforesaid obligations, the Executive Director (Operations-I), Sindh Solid Waste Management Board /Director (GTS) / Engineer shall issue a Maintenance Certificate whereupon all obligations of the Contractor under this Contract shall come to an end. Failure to remedy any such defects or complete outstanding work within a reasonable time shall entitle the Executive Director (Operations-I), Sindh Solid Waste Management Board to carry out all necessary works at the Contractor's cost. However, the cost of remedying defects not attributable to the Contractor shall be valued as a Variation.

9.2 Uncovering and Testing

The Director (GTS) / Engineer/ Executive Director (Operations-I), Sindh Solid Waste Management Board may give instruction as to the uncovering and/or testing of any work. Unless as a result of an uncovering and/or testing it is established that the Contractor's design, materials, plant or workmanship are not in accordance with the Contract, the Contractor shall be paid for such uncovering and/or testing as a Variation in accordance with Sub-Clause 10.2.

10. VARIATIONS AND CLAIMS

10.1 Right to Vary

The Executive Director (Operations-I), Sindh Solid Waste Management Board may issue Variation Order(s) in writing. Where for any reason it has not been possible for the Executive Director (Operations-I), Sindh Solid Waste Management Board /Director (GTS) / Engineer to issue such Variations Order(s), the Contractor may confirm any verbal orders given by the Executive Director (Operations-I), Sindh Solid Waste Management Board /Director (GTS) / Engineer in writing and if the same are not refuted/denied by the Executive Director (Operations-I), Sindh Solid Waste Management Board /Director (GTS) / Engineer within ten (10) days of the receipt of such confirmation the same shall be deemed to be a Variation Orders for the purposes of this Sub-Clause.

10.2 Valuation of Variations

Variations shall be valued as follows:

- a) Preferably contractor should submit a rate and its rate analysis for approval if demanded by the Director (GTS) / Engineer, and the Director (GTS) / Engineer will be final authority of approval.
- b) at a lump sum price agreed between the Parties, or
- c) where appropriate, at rates in the Contract, or
- d) in the absence of appropriate rates, the rates in the Contract shall be used as the basis for valuation, or failing which
- e) at appropriate new rates, as may be agreed or which the Director (GTS) / Engineer considers appropriate, or
- f) if the Director (GTS) / Engineer so instructs, at day work rates set out in the Contract Data for which the Contractor shall keep records of hours of labour and Contractor's Equipment, and of Materials, used.

10.3 Changes in the Quantities.

- a) If the final quantity of the work done differs from the quantity in the Bill of Quantities for the particular item by more than 45% percent (weather increase or decrease), provided the change exceeds 1 percent of the Initial Contract Price, the Director (GTS) / Engineer shall adjust the rate to allow for the change and will be valued as per sub clause 10.2.
- b) The Director (GTS) / Engineer shall not adjust rates from changes in quantities if thereby the Initial Contract Price is exceeded by more than 15 percent, except with the prior approval of the Executive Director (Operations-I), Sindh Solid Waste Management Board.
- c) If requested by the Director (GTS) / Engineer, the contractor shall provide the Director (GTS) / Engineer with a detailed cost breakdown of any rate in the Bill of Quantities. Change in drawings the construction drawings can be different from tender drawings, hence advised to visit site and consultant Director (GTS) / Engineer before quoting rates.

10.4 Early Warning

The Contractor shall notify the Director (GTS) / Engineer/ Executive Director (Operations-I), Sindh Solid Waste Management Board in writing as soon as

he is aware of any circumstance which may delay or disrupt the Works, or which may give rise to a claim for additional payment. To the extent of the Contractor's failure to notify, which results to the Director (GTS) / Engineer/ Executive Director (Operations-I), Sindh Solid Waste Management Board being unable to keep all relevant records or not taking steps to minimize any delay, disruption, or Cost, or the value of any Variation, the Contractor's entitlement to extension of the Time for Completion or additional payment shall be reduced/rejected.

10.5 Valuation of Claims

If the Contractor incurs Cost as a result of any of the Executive Director (Operations-I), Sindh Solid Waste Management Board's Risks, the Contractor shall be entitled to the amount of such Cost. If as a result of and Executive Director (Operations-I), Sindh Solid Waste Management Board Risk, it is necessary to change the Works, this shall be dealt with as a Variation subject to Contractor's notification for intention of claim to the Director (GTS) / Engineer within fourteen (14) days of the occurrence of cause.

10.6 Variation and Claim Procedure

The Contractor shall submit to the Director (GTS) / Engineer an itemized detailed breakdown of the value of variations and claims within twenty eight (28) days of the instruction or of the event giving rise to the claim. The Director (GTS) / Engineer/ Executive Director (Operations-I), Sindh Solid Waste Management Board shall check and if possible agree the value. In the absence of agreement, the Executive Director (Operations-I), Sindh Solid Waste Management Board shall determine the value.

11. CONTRACT PRICE AND PAYMENT

11.1 (a) Terms of Payments

The amount due to the Contractor under any Interim Payment Certificate issued by the Director (GTS) / Engineer pursuant to this Clause, or to any other terms of the Contract, shall, subject to Clause 11.3, be paid by the Executive Director (Operations-I), Sindh Solid Waste Management Board certificate has been jointly verified by Executive Director (Operations-I), Sindh Solid Waste Management Board and Contractor, or, in the case of the Final Certificate referred to in Sub Clause 11.5, within 60 days after such Final Payment Certificate has been jointly verified by Executive Director (Operations-I), Sindh Solid Waste Management Board and Contractor; Provided that the Interim Payment shall be caused in thirty (30) days and Final Payment in 60 days in case of foreign funded project. In the event of the failure of the Executive Director (Operations-I), Sindh Solid Waste Management Board to make payment within 90 days then Executive Director (Operations-I), Sindh Solid Waste Management Board shall pay to the Contractor compensation at the 28 days rate of KIBOR+2% per annum in local currency and LIBOR+1% for foreign currency, upon all sums unpaid from the date by which the same should have been paid.

(b) Valuation of the Works

The Works shall be valued as provided for in the Contract Data, subject to Clause 10.

11.2 Monthly Statements

The Contractor shall be entitled to be paid at monthly intervals:

- a) The value of the Works executed less to the cumulative amount paid previously; and
- b) Value of secured advance on the materials and valuation of variations (if any).

The Contractor shall submit each month to the Director (GTS) / Engineer/ Executive Director (Operations-I), Sindh Solid Waste Management Board a statement showing the amounts to which he considers himself entitled.

11.3 Interim Payments

Within a period not exceeding seven (07) days from the date of submission of a statement for interim payment by the Contractor, the Director (GTS) / Engineer shall verify the same and within a period not exceeding thirty (30/60) days from the said date of submission by the Contractor, the Executive Director (Operations-I), Sindh Solid Waste Management Board shall pay to the Contractor the sum subject to adjustment for deduction of the advance payments and retention money.

11.4 Retention

Retention money shall be paid by the Executive Director (Operations-I), Sindh Solid Waste Management Board to the Contractor within fourteen (14) days after either the expiry of the period stated in the Contract Data, or the remedying of notified defects, or the completion of outstanding work, all as referred to in Sub-Clause 9.1, whichever is the later.

11.5 Final Payment

Within twenty one (21) days from the date of issuance of the Maintenance Certificate the Contractor shall submit a final account to the Director (GTS) / Engineer to verify and the Director (GTS) / Engineer shall verify the same within fourteen (14) days from the date of submission and forward the same to the Executive Director (Operations-I), Sindh Solid Waste Management Board together with any documentation reasonably required to enable the Executive Director (Operations-I), Sindh Solid Waste Management Board to ascertain the final contract value. Within sixty (60) days from the date of receipt of the verified final account from the Director (GTS) / Engineer, the Executive Director (Operations-I), Sindh Solid Waste Management Board shall pay to the Contractor any amount due to the Contractor. While making such payment the Executive Director (Operations-I), Sindh Solid Waste Management Board may, for reasons to be given to the Contractor in writing, withhold any part or parts of the verified amount.

11.6 Currency

Payment shall be in the currency stated in the Contract Data.

12. DEFAULT

12.1 Defaults by Contractor

If the Contractor abandons the Works, refuses or fails to comply with a valid instruction of the Director (GTS) / Engineer/ Executive Director

(Operations-I), Sindh Solid Waste Management Board or fails to proceed expeditiously and without delay, or is, despite a written complaint, in breach of the Contract, the Executive Director (Operations-I), Sindh Solid Waste Management Board may give notice referring to this Sub-Clause and stating the default. If the Contractor has not taken all practicable steps to remedy the default within fourteen (14) days after receipt of the Executive Director (Operations-I), Sindh Solid Waste Management Board notice, the Executive Director (Operations-I), Sindh Solid Waste Management Board may by a second notice given within a further twenty one (21) days, terminate the Contract. The Contractor shall then demobilize from the Site leaving behind any Contractor's Equipment which the Executive Director (Operations-I), Sindh Solid Waste Management Board instructs, in the second notice, to be used for the completion of the Works at the risk and cost of the Contractor.

12.2 Defaults by Executive Director (Operations-I), Sindh Solid Waste Management Board

If the Executive Director (Operations-I), Sindh Solid Waste Management Board fails to pay in accordance with the Contract, or is, despite a written complaint, in breach of the Contract, the Contractor may give notice referring to this Sub-Clause and stating the default. If the default is not remedied within fourteen (14) days after the Executive Director (Operations-I), Sindh Solid Waste Management Board receipt of this notice, the Contractor may suspend the execution of all or parts of the Works. If the default is not remedied within twenty eight (28) days after the Executive Director (Operations-I), Sindh Solid Waste Management Board receipt of the Contractor's notice, the Contractor may by a second notice given within a further twenty one (21) days, terminate the Contract. The Contractor shall then demobilize from the Site.

12.3 Insolvency

If a Party is declared insolvent under any applicable law, the other Party may by notice terminate the Contract immediately. The Contractor shall then demobilize from the site leaving behind, in the case of the Contractor's insolvency, any Contractor's Equipment which the Executive Director (Operations-I), Sindh Solid Waste Management Board instructs in the notice is to be used for the completion of the Works.

12.4 Payment upon Termination

After termination, the Contractor shall be entitled to payment of the unpaid balance of the value of the works executed and of the Materials and Plant reasonably delivered to the site, adjusted by the following:

- a) Any sums to which the Contractor is entitled under Sub-Clause 10.4,
- b) Any sums to which the Executive Director (Operations-I), Sindh Solid Waste Management Board is entitled,
- c) If the Executive Director (Operations-I), Sindh Solid Waste Management Board has terminated under Sub-Clause 12.1 or 12.3, the Executive Director (Operations-I), Sindh Solid Waste Management Board shall be entitled to a sum equivalent to twenty percent (20%) of the value of parts of the Works not

executed at the date of the termination, and

d) If the Contractor has terminated under Sub-Clause 12.2 or 12.3, the Contractor shall be entitled to the cost of his demobilization together with a sum equivalent to ten percent (10%) of the value of parts of the works not executed at the date of termination.

The net balance due shall be paid or repaid within twenty eight (28) days of the notice of termination.

13. RISKS AND RESPONSIBILITIES

13.1 Contractor's Care of the Works

Subject to Sub-Clause 9.1, the Contractor shall take full responsibility for the care of the Works from the Commencement Date until the date of the Executive Director (Operations-I), Sindh Solid Waste Management Board /Director (GTS) / Engineer's issuance of Certificate of Completion under Sub-Clause 8.2. Responsibility shall then pass to the Executive Director (Operations-I), Sindh Solid Waste Management Board. If any loss or damage happens to the Works during the above period, the Contractor shall rectify such loss or damage so that the Works conform with the Contract. Unless the loss or damage happens as a result of any of the Executive Director (Operations-I), Sindh Solid Waste Management Board d Risks, the Contractor shall indemnify the Executive Director (Operations-I), Sindh Solid Waste Management Board or his agents against all claims loss, damage and expense arising out of the Works.

13.2 Force Majeure

If Force Majeure occurs, the Contractor shall notify the Director (GTS) / Engineer/ Executive Director (Operations-I), Sindh Solid Waste Management Board immediately. If necessary, the Contractor may suspend the execution of the Works and, to the extent agreed with the Executive Director (Operations-I), Sindh Solid Waste Management Board. If the event continues for a period of eighty four (84) days, either Party may then give notice of termination which shall take effect twenty eight (28) days after the giving of the notice.

After termination, the Contractor shall be entitled to payment of the unpaid balance of the value of the Works executed and of the Materials and Plant reasonably delivered to the Site, adjusted by the following:

- a) Any sums to which the Contractor is entitled under Sub-Clause 10.4,
- b) The cost of his demobilization, and
- c) Less any sums to which the Executive Director (Operations-I), Sindh Solid Waste Management Board is entitled.

The net balance due shall be paid or repaid within thirty five (35) days of the notice of termination.

14. INSURANCE

14.1 Arrangements

The Contractor shall, prior to commencing the Works, effect insurances of the types, in the amounts and naming as insured the persons stipulated in the

Contract Data except for items (a) to (e) and (i) of the Executive Director (Operations-I), Sindh Solid Waste Management Board 's Risks under Sub-Clause 6.1. The policies shall be issued by insurers and in terms approved by the Executive Director (Operations-I), Sindh Solid Waste Management Board. The Contractor shall provide the Director (GTS) / Engineer/ Executive Director (Operations-I), Sindh Solid Waste Management Board with evidence that any required policy is in force and that the premiums have been paid.

14.2 Default

If the Contractor fails to effect or keep in force any of the insurances referred to in the previous Sub-Clause, or fails to provide satisfactory evidence, policies or receipts, the Executive Director (Operations-I), Sindh Solid Waste Management Board may, without prejudice to any other right or remedy, effect insurance for the cover relevant to such as a default and pay the premiums due and recover the same plus a sum in percentage given in Contractor Data from any other amounts due to the Contractor.

15. RESOLUTION OF DISPUTES

15.1 Director (GTS) / Engineer's Decision

If a dispute of any kind whatsoever arises between the Executive Director (Operations-I), Sindh Solid Waste Management Board and the Contractor in connection with the works, the matter in dispute shall, in the first place, be referred in writing to the Director (GTS) / Engineer, with a copy to the other party. Such reference shall state that it is made pursuant to this Clause. No later than the twenty eight (28) days after the day on which he received such reference, the Director (GTS) / Engineer shall give notice of his decision to the Executive Director (Operations-I), Sindh Solid Waste Management Board (Director (GTS) / Engineer) and the Contractor.

Unless the Contract has already been repudiated or terminated, the Contractor shall, in every case, continue to proceed with the work with all due diligence, and the Contractor and the Executive Director (Operations-I), Sindh Solid Waste Management Board (Director (GTS) / Engineer) shall give effect forthwith to every such decision of the Director (GTS) / Engineer unless and until the same shall be revised, as hereinafter provided in an arbitral award.

15.2 Notice of Dissatisfaction

If a Party is dissatisfied with the decision of the Director (GTS) / Engineer of consultant or if no decision is given within the time set out in Sub-Clause 15.1 here above, the Party may give notice of dissatisfaction referring to this Sub-Clause within fourteen (14) days of receipt of the decision or the expiry of the time for the decision. If no notice of dissatisfaction is given within the specified time, the decision shall be final and binding on the Parties. If notice of dissatisfaction is given within the specified time, the decision shall be binding on the Parties who shall give effect to it without delay unless and until the decision of the Director (GTS) / Engineer is revised by an arbitrator. If a contractor is dissatisfied with the decision of the Director (GTS) / Engineer of the department or decision is not given in time then he can approach Executive Director (Operations-I), Sindh Solid

Waste Management Board within 14 days, in case of dissatisfaction with decision of Executive Director (Operations-I), Sindh Solid Waste Management Board or not decided within 28 days, then arbitration process would be adopted as per clause 15.3.

15.3 Arbitration

A dispute which has been the subject of a notice of dissatisfaction shall be finally settled as per provisions of Arbitration Act 1940 (Act No. X of 1940) and Rules made there under and any statutory modifications thereto. Any hearing shall be held at the place specified in the Contract Data and in the language referred to in Sub-Clause 1.5.

16 INTEGRITY PACT

16.1 If the Contractor or any of his Sub-Contractors, agents or servants is found to have violated or involved in violation of the Integrity Pact signed by the Contractor as Schedule-F to his Bid, then the Executive Director (Operations-I), Sindh solid wastage management board shall be entitled to:

- (a) recover from the Contractor an amount equivalent to ten times the sum of any commission, gratification, bribe, finder's fee or kickback given by the Contractor or any of his Sub-Contractors, agents or servants;
- (b) Terminate the Contract; and
- (c) recover from the Contractor any loss or damage to the Executive Director (Operations-I), Sindh Solid Waste Management Board as a result of such termination or of any other corrupt business practices of the Contractor or any of his Sub-Contractors, agents or servants.

On termination of the Contract under Sub-Para (b) of this Sub-Clause, the Contractor shall demobilize from the site leaving behind Contractor's Equipment which the Executive Director (Operations-I), Sindh Solid Waste Management Board instructs, in the termination notice, to be used for the completion of the works at the risk and cost of the Contractor. Payment upon such termination shall be made under Sub-Clause 12.4, in accordance with Sub-Para (c) thereof, after having deducted the amounts due to the Executive Director (Operations-I), Sindh Solid Waste Management Board under Sub-Para (a) and (c) of this Sub-Clause.

CONTRACT DATA

Sub-Clauses of Conditions of Contract

- 1.1.3 Procuring Agency Drawings, (*attached*)
- 1.1.4 The Procuring Agency means
Executive Director (Operations-I), Sindh Solid Waste Management Board
- 1.1.5 **The Contractor** means

- 1.1.7 **Commencement Date** means the date of issue of Director (GTS) / Engineer's Notice to Commence which shall be issued within Seven (07) days of the signing of the Contract Agreement.
- 1.1.9 **Time for Completion**
18 months
- 1.1.20 **Director (GTS) / Engineer (mention the name along with the designation including whether he belongs to department or consultant) and other details**
Executive Director (Operations-I), Sindh Solid Waste Management Board
- 1.3 **Documents forming the Contract listed in the order of priority:**
- (a) The Contract Agreement
 - (b) Letter of Acceptance
 - (c) The completed Form of Bid
 - (d) Contract Data
 - (e) Conditions of Contract
 - (f) The completed Schedules to Bid including Schedule of Prices (g).
 - (g) The Drawings, (Attached)
 - (h) The Specifications
- 2.1 **Provision of Site:** On the Commencement Date
- 3.1 **Authorized person:**
Executive Director (Operations-I), Sindh Solid Waste Management Board
- 3.2 Name and address of **Executive Director (Operations-I), Sindh Solid Waste Management** representative:
Director (GTS) / Engineer
- 4.4 **Performance Security:**
2%
- 5.1 **Requirements for Contractor's design (if any):**
Specification Clause No's N/A

- 7.2 **Programme:**
Time for submission: Within fourteen (14) days* of the Commencement Date.
Form of programme: _____ (*Bar Chart/CPM/PERT or other*)
- 7.4 Amount payable due to failure to complete shall be 2% per day up to a maximum of (10%) of sum stated in the Letter of Acceptance (Usually the liquidated damages are set between 0.05 percent and 0.10 percent per day.)
- 7.5 **Early Completion**
In case of earlier completion of the Work, the Contractor is entitled to be paid bonus up-to limit and at a rate equivalent to 50% of the relevant limit and rate of liquidated damages stated in the contract data.
- 9.1 **Period for remedying defects**
as per bidding documents
- 10.2 (e) **Variation procedures:**
Day work rates as per bidding documents
- 11.1 **Terms of Payments**
a) **Mobilization Advance**
Mobilization advance shall not be applicable
- 11.2 **Valuation of the Works:**
i) Lump sum price _____ (details), or
ii) Lump sum price with schedules of rates _____ (details), or
iii) Lump sum price with bill of quantities _____ (details), or
iv) Re-measurement with estimated/bid quantities in the Schedule of Prices or on premium above or below quoted on the rates mentioned in CSR _____ (details), or/and
v) Cost reimbursable _____ (details).

STANDARD FORMS

(Note: Standard Forms provided in this document for securities are to be issued by a bank. In case the bidder chooses to issue a bond for accompanying his bid or performance of contract or receipt of advance, the relevant format shall be tailored accordingly without changing the spirit of the Forms of securities).

FORM OF BID SECURITY

(Bank Guarantee)

Guarantee No. _____

Executed on _____

(Letter by the Guarantor to the Executive Director (Operations-I),
Sindh Solid Waste Management Board)

Name of Guarantor (Scheduled Bank in Pakistan) with address:

Name of Principal (Bidder) with address:

Sum of Security (express in words and figures):

Bid Reference No. _____ Date of Bid _____

KNOW ALL MEN BY THESE PRESENTS, that in pursuance of the terms of the Bid and at the request of the said Principal, we the Guarantor above-named are held and firmly bound unto the _____, (hereinafter called Executive Director (Operations-I), Sindh Solid Waste Management Board) in the sum stated above, for the payment of which sum well and truly to be made, we bind ourselves, our heirs, executors, administrators and successors, jointly and severally, firmly by these presents.

THE CONDITION OF THIS OBLIGATION IS SUCH, that whereas the Principal has submitted the accompanying Bid numbered and dated as above for _____ (Particulars of Bid) to the said Executive Director (Operations-I), Sindh Solid Waste Management Board; and

WHEREAS, the Executive Director (Operations-I), Sindh Solid Waste Management Board has required as a condition for considering the said Bid that the Principal furnishes a Bid Security in the above said sum to the Executive Director (Operations-I), Sindh Solid Waste Management Board, conditioned as under:

- (1) That the Bid Security shall remain valid for a period of twenty eight (28) days beyond the period of validity of the bid;

- (2) That in the event of;
- (a) The Principal withdraws his Bid during the period of validity of Bid, or
 - (b) The Principal does not accept the correction of his Bid Price, pursuant to Sub-Clause 16.4 (b) of Instructions to Bidders, or
 - (c) Failure of the successful bidder to
 - (i) Furnish the required Performance Security, in accordance with Sub-Clause IB-21.1 of Instructions to Bidders, or
 - (ii) Sign the proposed Contract Agreement, in accordance with Sub-Clauses IB-20.2 & 20.3 of Instructions to Bidders,

The entire sum be paid immediately to the said Executive Director (Operations-I), Sindh Solid Waste Management Board for delayed completion and not as penalty for the successful bidder's failure to perform.

NOW THEREFORE, if the successful bidder shall, within the period specified therefore, on the prescribed form presented to him for signature enter into a formal Contract Agreement with the said Executive Director (Operations-I), Sindh Solid Waste Management Board in accordance with his Bid as accepted and furnish within fourteen (14) days of receipt of Letter of Acceptance, a Performance Security with good and sufficient surety, as may be required, upon the form prescribed by the said Executive Director (Operations-I), Sindh Solid Waste Management Board for the faithful performance and proper fulfillment of the said Contract or in the event of non-withdrawal of the said Bid within the time specified then this obligation shall be void and of no effect, but otherwise to remain in full force and effect.

PROVIDED THAT the Guarantor shall forthwith pay to the Executive Director (Operations-I), Sindh Solid Waste Management Board the said sum stated above upon first written demand of the Executive Director (Operations-I), Sindh Solid Waste Management Board without cavil or argument and without requiring the Executive Director (Operations-I), Sindh Solid Waste Management Board to prove or to show grounds or reasons for such demand, notice of which shall be sent by the Executive Director (Operations-I), Sindh Solid Waste Management Board

PROVIDED ALSO THAT the Executive Director (Operations-I), Sindh Solid Waste Management Board shall be the sole and final judge for deciding whether the Principal has duly performed his obligations to sign the Contract Agreement and to furnish the requisite Performance Security within the time stated above, or has defaulted in fulfilling said requirements and the Guarantor shall pay without objection the sum stated above upon first written demand from the Executive Director (Operations-I), Sindh Solid Waste Management Board forthwith and without any reference to the Principal or any other person.

IN WITNESS WHEREOF, the above bounded Guarantor has executed the instrument under its seal on the date indicated above, the name and seal of the Guarantor being hereto affixed and these presents duly signed by its undersigned representative pursuant to authority of its governing body.

Guarantor (Bank)

Witness:

1. _____

Corporate Secretary
(Seal)

1. Signature _____

2. Name _____

3. Title _____

2. _____

(Name, Title & Address)

Corporate Guarantor (Seal)

**FORM OF PERFORMANCE SECURITY
(Bank Guarantee)**

Guarantee No. _____
Executed on _____
Expiry Date _____

(Letter by the Guarantor to the Executive Director (Operations-I), Sindh Solid Waste Management Board)

Name of Guarantor (Scheduled Bank in Pakistan) with address:

Name of Principal (Contractor) with address:

Penal Sum of Security (express in words and figures)

Letter of Acceptance No. _____ Dated _____

KNOW ALL MEN BY THESE PRESENTS, that in pursuance of the terms of the Bidding Documents and above said Letter of Acceptance (hereinafter called the Documents) and at the request of the said Principal we, the Guarantor above named, are held and firmly bound unto the _____ (hereinafter called the Executive Director (Operations-I), Sindh Solid Waste Management Board) in the penal sum of the amount stated above, for the payment of which sum well and truly to be made to the said Executive Director (Operations-I), Sindh Solid Waste Management Board, we bind ourselves, our heirs, executors, administrators and successors, jointly and severally, firmly by these presents.

THE CONDITION OF THIS OBLIGATION IS SUCH, that whereas the Principal has accepted the Executive Director (Operations-I), Sindh Solid Waste Management Board's above said Letter of Acceptance for _____ (Name of Contract) for the _____ (Name of Project).

NOW THEREFORE, if the Principal (Contractor) shall well and truly perform and fulfill all the undertakings, covenants, terms and conditions of the said Documents during the original terms of the said Documents and any extensions thereof that may be granted by the Executive Director (Operations-I), Sindh Solid Waste Management Board all also well and truly perform and fulfill all the undertakings, covenants terms and conditions of the Contract and of any and all modifications of the said Documents that may hereafter be made, notice of which modifications to the Guarantor being hereby waived, then,

this obligation to be void; otherwise to remain in full force and virtue till all requirements of Clause 9, Remediating Defects, of Conditions of Contract are fulfilled.

Our total liability under this Guarantee is limited to the sum stated above and it is a condition of any liability attaching to us under this Guarantee that the claim for payment in writing shall be received by us within the validity period of this Guarantee, failing which we shall be discharged of our liability, if any, under this Guarantee.

We, _____ (the Guarantor), waiving all objections and defenses under the Contract, do hereby irrevocably and independently guarantee to pay to the Executive Director (Operations-I), Sindh Solid Waste Management Board without delay upon the Executive Director (Operations-I), Sindh Solid Waste Management Board first written demand without cavil or arguments and without requiring the Executive Director (Operations-I), Sindh Solid Waste Management Board to prove or to show grounds or reasons for such demand any sum or sums up to the amount stated above, against the Executive Director (Operations-I), Sindh Solid Waste Management Board's written declaration that the Principal has refused or failed to perform the obligations under the Contract, for which payment will be effected by the Guarantor to Executive Director (Operations-I), Sindh Solid Waste Management Board designated Bank & Account Number.

PROVIDED ALSO THAT the Executive Director (Operations-I), Sindh Solid Waste Management Board shall be the sole and final judge for deciding whether the Principal (Contractor) has duly performed his obligations under the Contract or has defaulted in fulfilling said obligations and the Guarantor shall pay without objection any sum or sums up to the amount stated above upon first written demand from the Executive Director (Operations-I), Sindh Solid Waste Management Board forthwith and without any reference to the Principal or any other person.

IN WITNESS WHEREOF, the above bounded Guarantor has executed this Instrument under its seal on the date indicated above, the name and corporate seal of the Guarantor being hereto affixed and these presents duly signed by its undersigned representative, pursuant to authority of its governing body.

Witness:

1. _____

Corporate Secretary (Seal)

2. _____

(Name, Title & Address)

Guarantor (Bank)

1. Signature _____

2. Name _____

3. Title _____

Corporate Guarantor (Seal)

FORM OF CONTRACT AGREEMENT

THIS CONTRACT AGREEMENT (hereinafter called the Agreement) made on the ___ day of _____ 2016 ___ between _____(hereinafter called the Executive Director (Operations-I), Sindh Solid Waste Management Board) of the one part and _____ (hereinafter called the Contractor) of the other part.

WHEREAS the Executive Director (Operations-I), Sindh Solid Waste Management Board is desirous that certain Works, viz _____ should be executed by the Contractor and has accepted a Bid by the Contractor for the execution and completion of such Works and the remedying of any defects therein.

NOW this Agreement witnessed as follows:

1. In this Agreement words and expressions shall have the same meanings as are respectively assigned to them in the Conditions of Contract hereinafter referred to.
2. The following documents after incorporating addenda, if any except those parts relating to Instructions to Bidders, shall be deemed to form and be read and construed as part of this Agreement, viz:
 - (a) The Letter of Acceptance;
 - (b) The completed Form of Bid along with Schedules to Bid;
 - (c) Conditions of Contract & Contract Data;
 - (d) The priced Schedule of Prices/Bill of quantities (BOQ);
 - (e) The Specifications; and
 - (f) The Drawings (attached).
3. In consideration of the payments to be made by the Executive Director (Operations-I), Sindh Solid Waste Management Board to the Contractor as hereinafter mentioned, the Contractor hereby covenants with the Executive Director (Operations-I), Sindh Solid Waste Management Board to execute and complete the Works and remedy defects therein in conformity and in all respects within the provisions of the Contract.
4. The Executive Director (Operations-I), Sindh Solid Waste Management Board hereby covenants to pay the Contractor, in consideration of the execution and completion of the Works as per provisions of the Contract, the Contract Price or such other sum as may become payable under the provisions of the Contract at the times and in the manner prescribed by the Contract.

IN WITNESS WHEREOF the parties hereto have caused this Contract Agreement to be executed on the day, month and year first before written in accordance with their respective laws.

Signature of the Contactor

Signature of the Executive Director
(Operations-I), Sindh Solid Waste
Management Board

(Seal)

(Seal)

Signed, Sealed and Delivered in the presence of:

Witness:

Witness:

(Name, Title and Address)

(Name, Title and Address)

SPECIFICATIONS

[Note for Preparing the Specifications]

A set of precise and clear specifications is a prerequisite for bidders to respond realistically and competitively to the requirements of the user without qualifying their Bids. The specifications must be drafted to permit the widest possible competition and, at the same time, present a clear statement of the required standards of workmanship, materials, performance of the works. Only if this is done objectives of economy, efficiency, and fairness in procurement will be realized and responsiveness of Bids can be ensured, and the subsequent task of bid evaluation can be facilitated. The specifications should require that materials to be incorporated in the works be new, unused, and of the most recent or current models, and incorporated all recent improvements in design and materials unless provided for otherwise in the contract.

Samples of specifications from similar to previous procurements are useful in this respect. The use of metric units is encouraged. Depending on the complexity of the works and the repetitiveness of the type of procurement, it may be advantageous to standardize the Technical Specifications that should cover all classes of workmanship, materials and equipment although not necessarily to be used in a particular procurement.

Care must be taken in drafting specifications to ensure that they are not restrictive. In the specification of standards for equipment, materials, and workmanship, recognized international standards should be used as much as possible. The specifications shall consider all conditions but not limited to seismic conditions, weather conditions and environmental impact. The specifications should state that equipment, materials, and workmanship that meet other authoritative standards, and which ensure at least a substantially equal quality than the standards mentioned, will also be acceptable. The following clause may be inserted in the Specifications.

Sample Clause: Equivalency of Standards and Codes

Wherever reference is made in the Specifications to specific standards and codes to be met by Works to be furnished and tested, the provisions of the latest current edition or revision of the relevant shall apply, unless otherwise expressly stated in the Contract. Other authoritative standards that ensure equivalence to the standards and codes specified will be acceptable.]

LOCATION OF SITES (GTSs)

1. GTS Hawks-bay District West
2. GTS Dhobi Ghat, District South
3. GTS Deh Okewari Near Baidal Colony, District East
4. GTS Deh Gangiaro Survey No.28 & 29 Bin Qasim District Malir
5. GTS Murtaza Chowrangi District Korangi
6. GTS EPM Causeway District Korangi

Note:

The location of the above mentioned sites for GTSs can increased or decreased due to change in location (if required)

***BILL OF QUANTIITES**

Construction of boundary wall on different sites of GTS @ Karachi. (Civil Works)

S. No.	Description	Quantity	Rate	Unit	Amount
1	Dismantling cement concrete 1 : 3 : 6	4250.00	1306.00	% cft	55,505
2	Dismantling cement concrete 1 : 2 : 4	5100.00	3327.50	% Cft	169,703
3	Dismantling cement concrete reinforced separating reinforcement from concrete cleaning and straightening the same.	1360.00	5445.00	% Cft	74,052
4	Excavation in foundation of building bridges and other structure i/c dag belling refilling around structure with excavated earth watering ramming lead up to 5ft (c) in hard soil (Gen. Sch. P. 4 Item No. 18 (b)).	125685.00	3176.25	%0 Cft	399,207
5	Excavation in rocks, dressed to designed section, grades and profiles, excavated material disposal off within 100ft. lift upto 5ft. Gen. Sch. Page no.2 6(b).	12568.50	10133.00	%0 Cft	127,357
6	Excavation in hard rock requiring blasting and disposal of excavation material (blasted material) upto 50 ft. lead (including dressing and leveling to dsigned section etc, complete (Gen P. 2 Item No. 7 (B))	12568.50	25936.00	%0 Cft	325,977
7	Stone pitching i/c sub-base with hammer dressed stone on surface laid-in courses i/c carriage of material chains	9600.00	5377.63	% CFt	516,252
8	Refilling the excavated stuff in trenches 6" thick layer i/c watering ramming to full compaction etc. complete.	96000.00	2500.00	% 0 Cft	240,000
9	Providing / Laying cement concrete brick or stone ballast 1½" to 2" gauge etc. complete (in ratio 1:4:8).	20947.50	2760.00	% Cft	578,151
10	Erection and removal of centering for R.C.C or plain cement concrete work of partial wood.	95760.00	9416.28	% Sft	9,017,030
11	P/L cement concrete plain including placing compacting finishing & curing etc. complete i/c screening and washing stone aggregate without shuttering (Gen. Sch. P -15/ 5 f)(in ratio 1:2:4)	47880.00	3127.41	% Cft	1,497,404

12	Reinforced cement concrete work i/c all labour material except the cost of steel reinforcement & its labour for binding & binding which will be paid separately. This rate also i/c all kinds of forms molds lifting shuttering curing, rendering & finishing the exposed surface (i/c screening & washing of single) RCC work in roof slab beams columns rafts lintels & other structural members laid in situ precast laid in position complete in all respect (90) lbs. cement 2 cft sand 4 cft single 8 to ¼ gauge) etc. complete (Gen. Sch. P-18/6-a (1) (Ratio 1:2:4)	31293.57	258.61	P-Cft	8,092,830
13	Fabrication of mild steel reinforcement using tore bars for cement concrete i/c cutting laying bending in position making joints & fastening i/c cost of binding wire (also i/c removal of rust from bars) etc complete (Gen Sch P-18/7.b)	1257.33	5001.70	P-Cwt	6,288,787
14	Providing / Laying 1:3:6 cement concrete Solid Block masonry wall 8" and below in thickness set in 1:6 cement sand mortar in ground floor super structure including raking out joints & curing etc. complete. (Sch. Buil. P-18 (22))	59052.00	15771.01	% Cft	9,313,097
15	Providing / Laying Cement Plaster ¾" thick in 1:4 ration upto 20 ft height etc. complete(Gen. Sch. P-57 / 11 (b-c)	255360.00	3015.76	% Sft	7,701,045
16	Making and fixing steel grated door complete with 1/16" thick sheeting including angle iron frame 2 x 2 x 3/8 and ¾" sq. yards 4" c/c with locking arrangement. (G.S.I No. 24 Page No. 91).	1728.00	726.72	P-Sft	1,255,772
17	White Washing One Coat (1st coat over primary coat).	255360.00	416.63	% Sft	1,063,906
18	Color washing two coats. (Gen Sch P. 53 Item No. 25 (b)	255360.00	859.90	% Sft	2,195,841
19	Preparing surface and painting of doors and windows any type, (including edge). (Gen. Sch. Page. 69 (c))	3456.00	2116.41	% Sft	73,143
20	Providing "expansion joint" in concrete work of 9" wide corrugated PVC water stop (with bulb) i.c soldering cost of material and labour etc complete. (Sch. PHED. Page. 56 Item No. 2)	2544.00	86.00	P-Rft	218,784
21	Hire Charges of Pumping set upto 10 HP Pumping out water from 20' deep trench	250.00	2500.00	P. Hr	625,000
22	Carriage of 100 Cft /05 Tons limits Surkhi Earth Reinforcement / Steel / Bajri / Aggregate / including loading & Unloading & stacking at Site etc. Complete. (12 Mile Lead)				
	Dismantling Cement Concrete 1:3:6	4250.00	1306.80	% Cft	55,539

Dismantling Cement Concrete 1:2:4	5100.00	3327.50	% Cft	169,703
Dismantling Cement Concrete reinforcement separating reinforcement from concrete cleaning and straightening the same	1360.00	5445.00	% Cft	74,052
TOTAL (Rs)				50,128,136

Premium quoted by the contractor	% above /below	
Grand to Amount in Rs.		
Grand to Amount in Words.	_____	

Tender are required to comply with all the clauses mentioned in the terms and conditions of the tender along with submission of all the relevant documents required. In case of any deviation / incomplete documents from tenderer will be prohibited for competing in the tender / render their offer in invalid.

Pay Order/ Demand Draft No _____ drawn on _____ (Name & address of the Bank) for an Amount of Rs. _____ in words (_____) of Bid Security equal to 2% of the total bid amount (original must be attached with Bid).

Full Name & Address of Firm _____

CNIC No. of authorized Person _____

Signature of Authorized Person _____

Seal / Stamp of Firm _____

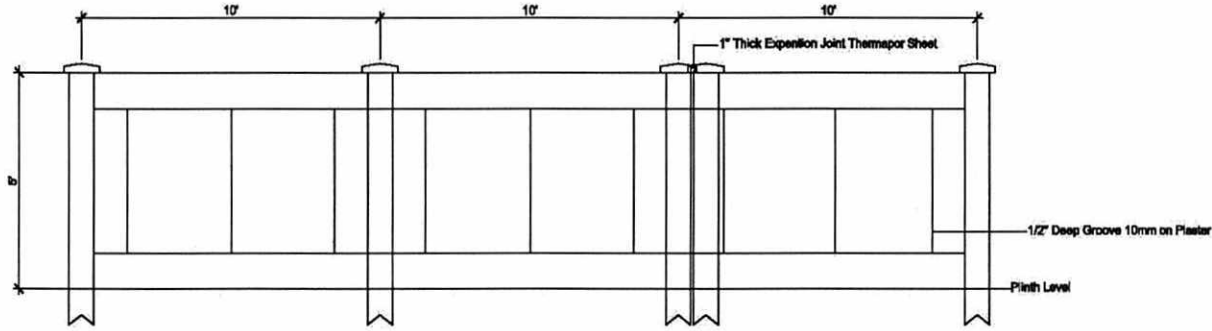

3/4" Cement Plaster Boundary Wall Detail Inner & Outer Side

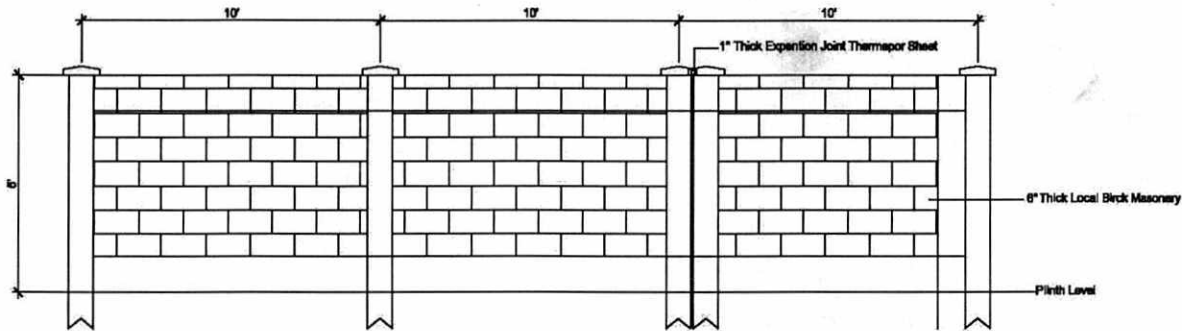

Block Masonry Boundary Wall Detail

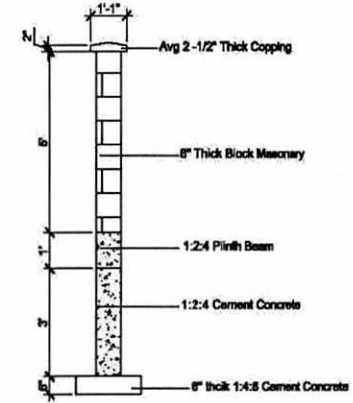

Situ & Wall Detail

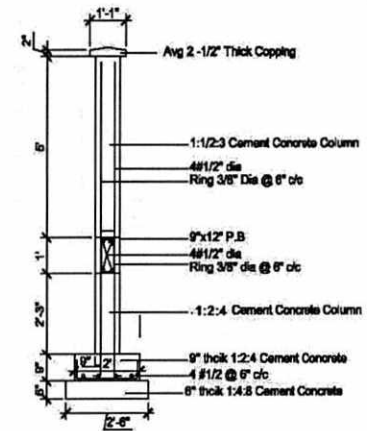

Column Footing Detail



GOVERNMENT OF SINDH



Transportation of Garbage from GTSs & other areas of District East, Karachi to Landfill Sites

Tender Reference: SSWMB - NIT - 10.1 /2017-18

BIDDING DOCUMENTS

Procuring Agency:

Sindh Solid Waste Management Board

Bungalow # 13, Al-Hamra Housing Society, Shaheed e Millat Road, Karachi

Ph # 021-9933 3704-06, Fax # 021-9933 3707 Email Address: info@sswmb.gos.pk

website: www.sswmb.gos.pk

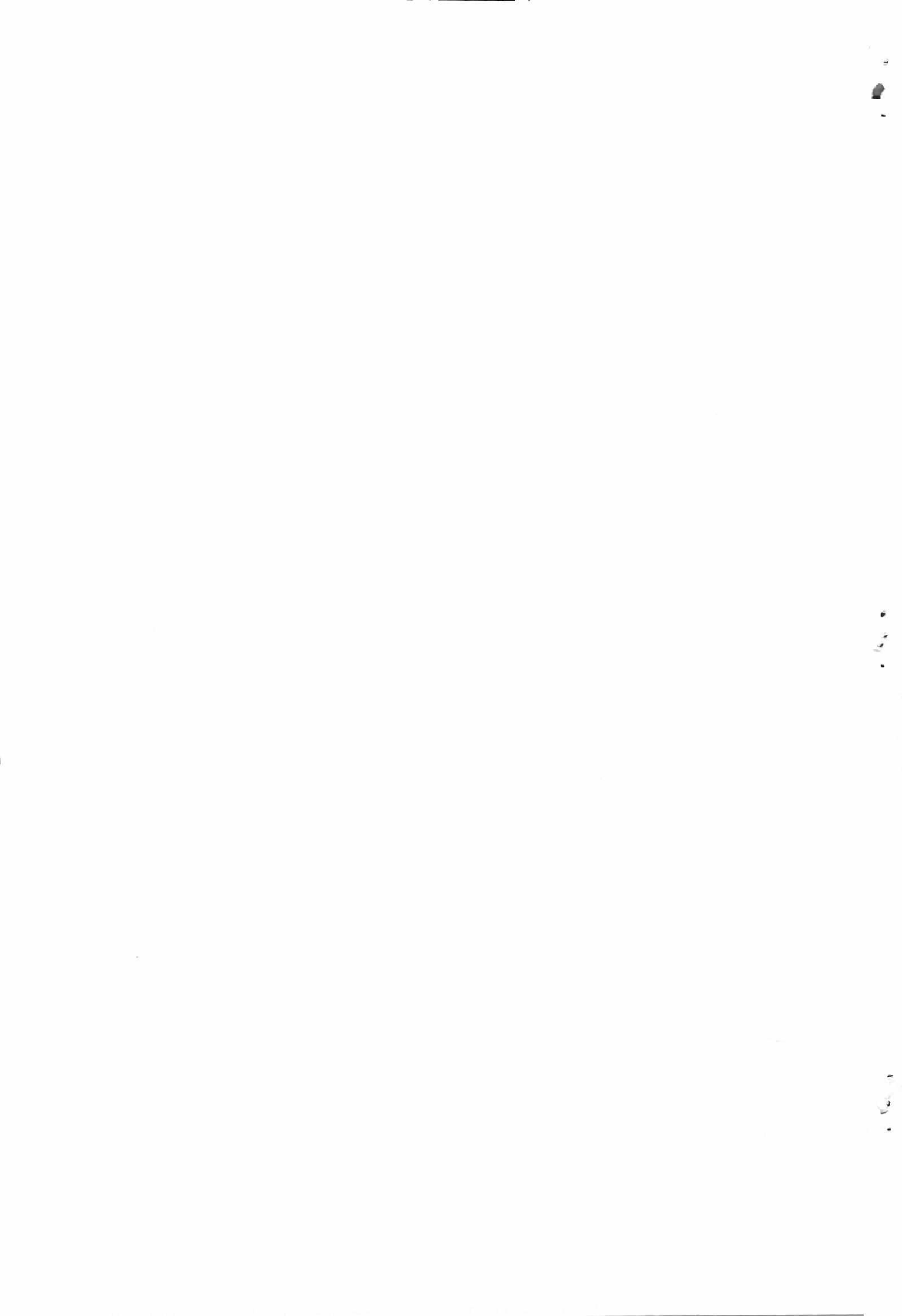

NOTICE INVITING TENDER
(SSWMB/NIT-9 & 10/ 2017-18)

Sindh Solid Waste Management Board (SSWMB) invites sealed bids from interested Contractors / Firms for carrying out the Works / Services mentioned below under *SINGLE STAGE – ONE ENVELOPE PROCEDURE*

TENDER REFERENCE NO.	NAME OF WORK	ESTIMATED COST	TENDER COST
NIT-9/2017-18			
NIT-9	Construction of Boundary Wall on different sites of GTS at Karachi. (Civil Works)	55.141 (Million)	Rs.3000/-
NIT-10/2017-18			
NIT-10.1	Transportation of Garbage from GTSs and other areas of District East, Karachi to Landfill Sites.	Open Rate	Rs.3000/- Each
NIT-10.2	Transportation of Garbage from GTSs and other areas of District South, Karachi to Landfill Sites.		
NIT-10.3	Transportation of Garbage from GTSs and other areas of District West, Karachi to Landfill Sites.		
NIT-10.4	Transportation of Garbage from GTSs and other areas of District Malir, Karachi to Landfill Sites.		
TENDER SCHEDULE			
Sr. No.	Schedule	Date & Time	Venue
1.	Issuance of Bidding Documents	From 11-12-2017 to 26-12-2017 (Both days inclusive) during office hours.	Office of Assistant Director (Finance), SSWMB, Bungalow No.13, Al-Hamra Housing Society - Karachi.
2.	Submission of Bids	26-12-2017 at 1500 hours	Committee Room, Sindh Solid Waste Management Board, Bungalow No.13, Al-Hamra Housing Society - Karachi.
3.	Opening of Bids	26-12-2017 at 1530 hours	

- Interested companies can obtain Tender Documents including eligibility criteria upon payment of Tender Document Fee (non-refundable) through **PAY ORDER OR BANK DRAFT of Pak Rs.3,000/- (for each work)** in favor of **Sindh Solid Waste Management Board** as per schedule given above from the office of **Assistant Director (Finance)**, SSWMB during office hours. Alternatively the documents may also be downloaded from the website www.pprasindh.gov.pk or www.sswmb.gos.pk. The companies downloading the documents from the websites must submit Tender Document Fee in the shape of Pay Order or Demand Draft as mentioned above at the time of submission of the bid.
- Bid Security of amount equivalent to 2% of the total quoted bid amount must be attached with the bids.
- Proof of Registration with FBR (NTN / Sales Tax) and Sindh Revenue Board (SRB) is to be submitted with the bids.
- The Bids must be in sealed envelope and submitted **SEPARATE FOR EACH WORK / SERVICES**.
- The envelope must clearly state:
 - Name of the Work (e.g. Transportation of Garbage from GTSs and other areas of District East, Karachi to Landfill Sites and;**
 - Tender Reference Number as mentioned on the bid document (e.g. SSWMB/NIT.10.1/2017-18).**
- In case, the date of opening of bids is declared as a public holiday or non-working day due to force Majeure, the next official working day shall be deemed to be date for issuance, submission and opening of tenders. The time and venue shall remain unchanged.
- Sindh Solid Waste Management Board** shall not be responsible for any cost or expenses incurred by bidding firms and reserves the right to terminate the procurement process at any time subject to relevant provision of SPP Rules, 2010 (Amended 2017).

Deputy Director (Procurement)

Sindh Solid Waste Management Board

Bungalow # 13, Al-Hamra Housing Society, Shaheed e Millat Road, Karachi

Ph # 021-9933 3704-06, Fax # 021-9933 3707 Email Address: info@sswmb.gos.pk website: www.sswmb.gos.pk.

**Transportation of Garbage from GTs and other areas of District East,
Karachi to Landfill Sites.
(SSWMB-NIT-10.1/2017-18)**

TENDER DOCUMENT	
SSWMB-NIT-10.1 (District East)	
Date and time of Submission:	26 th December 2017 latest by 1500 hours
Date and time of opening:	26 th December 2017 at 1530 hours
Place of opening:	Committee Room, Sindh Solid Waste Management Board, Bungalow No. 13, Al-Hamra Housing Society, Shaheed-e-Millat Road – Karachi
Date of issue:	
Name and address of Contractor:	_____
Contractor's Representative	
Name & Signature of Tender Issuing Officer:	
Bid Price:	
Offered Rate Rs. _____ (in words) Rupees _____ Per Ton	
[*Total Bid Amount Rs. _____	
(in words) Rupees _____]	
Bid Security 2% of the Total Quoted Bid amount only in the shape of Pay Order / Demand Draft No. _____ Bank / Branch _____ Dated _____	
Performance Security: 10%	
(2% at the time of agreement + 8% from running & final bill)	
Completion period: 12 months from date of award extendable for another month on the same rate and terms and conditions.	

CHECK LIST / COMPLIANCE TO MINIMUM ELIGIBILITY CRITERIA

(No bid shall be considered unless Minimum Eligibility Criteria is complied)

S. No.	Criteria / Requirement	Compliance Yes / No	Remarks
1.	Registration with FBR (NTN)		
2.	Registration with Sindh Revenue Board (SRB)		
3.	Valid Registration with Pakistan Engineering Council		
4.	Valid Registration with EPA		
5.	Relevant experience: The bidder should have at least 03 (Three) years experience in handling Solid Waste OR at least 03 (Three) years experience as Contractor of works involving transportation of material as a part of the construction or similar contract.		
6.	Proof of ability to carry out the work i.e. Detail of equipment machinery and transportation /owned/ leased hired by the bidder: i. Registration Books of Loaders / Dumpers owned by the bidders; OR ii. Agreement with Transport supplier along with Registration Number of machinery; OR iii. Any identical proof acceptable by the Procuring Committee.		
7.	List of similar assignments (Transportation of garbage or Construction Contracts) with cost, completed or under execution		
8.	List of litigation (if any) within last three (03) years, nature and status / out come		
9.	Affidavit / undertaking that firm has never been black listed		
10.	Each and Every page of bidding document signed		
11.	Proof of payment of Tender Fee		
12.	Bid Security attached (2% of the Total Quoted Bid amount): - Pay order / Draft / Bank Guarantee - Amount: Rs. -----/- (Rupees -----) - Bank & Branch ----- -----		

Contractor Signature

Name of the Contractor / Company: _____

Name of the Contractor / Authorized person _____

Address: _____

Phone: _____

Fax: _____

Email: _____

Date: _____

Seal of the Firm /

Instruction to bidders

Instruction to bidders and Conditions of Contract

General

1.1 Invitation for tenders

The Sindh Solid Waste Management Board (SSWMB) hereinafter referred as 'Procuring Agency' intends to invite sealed bids from the interested contractors / firms / companies having sufficient experience / resources for the following assignment / work:

Lifting of Garbage (Solid Waste), its Transportation and Disposal from Garbage Transfer Stations (Formal or Informal GTS, Temporary or Permanent) & other areas of DMC East Karachi to Landfill sites (Gondpass and Jam Chakro) as per detailed Scope of Work at 'Section 1.8' below

1.2 This contract shall be governed under SINGLE STAGE – ONE ENVELOPE PROCEDURE as set out in Sindh Public Procurement Rules 2010 (amended 2017).

1.3 All provisions of Sindh Public Procurement Rules 2010 (amended 2017), whether mentioned in this document or not, shall be applicable.

1.4 There is no bar on any contractor to participate in number of tenders i.e. A bidder can participate in tender for One, Two, or even all Four districts mentioned in Tender Notice. However, he will have to submit Separate Bid including Eligibility Criteria, Separate Tender Fee and Separate Bid Security for each District.

1.5 Manner and place, date and time for submission of bidding documents

Sealed bids along with Bid Security and proof of payment of tender fee should be submitted in the tender box of **Sindh Solid Waste Management Board (SSWMB), Bungalow No. 13, Al-Hamra Housing Society, Shaheed-e-Millat Road, Karachi not later than 1500 hours on 26th December 2017**. Bids can also be submitted through registered post or courier but SSWMB shall not be responsible for any delay in submission for whatsoever reasons. Bids submitted by fax, email or any other means except described above shall not be entertained.

1.6 Manner, place, date and time of opening of bids

The Bids shall be opened publicly by the Procurement Committee in presence of bidders or their representatives in **Committee Room of Sindh Solid Waste Management Board (SSWMB), Bungalow No. 13, Al-Hamra Housing Society, Shaheed-e-Millat Road, Karachi on 26th December 2017 at 1530 hours**.

In case, the date of opening of bids is declared as a public holiday or non-working day due to force Majeure, the next official working day shall be deemed to be date for issuance, submission and opening of tenders. The time and venue shall remain unchanged.

1.7 Sub-letting of work

The contractor shall not sublet the whole work or any part thereof. The bidder shall be responsible for execution of the contract / providing the services as per BoQ. Subletting shall not be permissible under this contract and shall lead to disqualification. However, hiring of machinery, from open market, for carrying out this work, shall NOT be considered as subletting of the work.

1.8 Scope of work

The work under this contract comprises of Lifting transportation and disposal of all types of garbage / solid waste (excluding hazardous waste) and including but not limited to domestic / commercial garbage, rubbish, shrub, tree cutting of any condition and from (fry, semi dry or wet) as well as old debris mixed with garbage and inseparable from its etc from Garbage Transfer Stations (whether located within DMC East Jurisdiction or outside its limits but used by DMC East as formal or informal, temporary or permanent GTS or intermediate point for transfer of Garbage) to landfill sites (Jam Chakro and Gond Pass) including loading / unloading haulage / transportation and weightage from the designated weighbridges.

1.9 Eligibility Criteria (Please refer to Minimum Eligibility Criteria at page No. 4)

- a) Registration with FBR (NTN);
- b) Registration with Sindh Revenue Board (SRB);
- c) Valid Registration with Pakistan Engineering Council;
- d) Valid Registration with EPA;
- e) Proof of payment of Tender Fee (Separate for Each District);
- f) Proof of payment of prescribed Bid Security (Separate for Each District);
- g) Relevant experience:
The bidder should have at least 03 (Three) years experience in handling Solid Waste

OR

at least 03 (Three) years experience as Contractor of works involving transportation of material (e.g. sand / building material) as a part of the contract.
- h) Proof of ability to carry out the work i.e. Detail of equipment machinery and transportation/owned/ leased hired by the bidder:
Arrangement of at least 03-05 heavy duty Loaders / Shovels and 16-20 (10-12 wheeler) Dump trucks with high walls or equivalent along with allied equipment.
Note:
 - i. The proof can be either copies of registration papers of vehicles or an agreement with Transportation Vehicle Supplier showing Registration Number, type and capacity of vehicles, which shall be made available specifically for this district work.
 - ii. The same vehicle can't be quoted for work of another district i.e. same vehicle will not be counted for more than one district to undertake this work in the shape of arrangement;

- iii. Any vehicle quoted by the contractor in any previous garbage lifting & transportation contract of SSWMB can't be re-quoted before expiry of that contract;
- iv. SSWMB reserves the right to carry out further checks to verify the ability of the bidder to accomplish the assignment.

- i) List of similar assignments with cost (mention number of projects) completed or under execution;
- j) List of litigation (if any) within last three (03) years, nature and status / outcome;
- k) Affidavit / Undertaking that firm has never been black listed;

1.10 Definition and interpretation

In this as document following words and expressions shall have the meaning hereby assigned to them, unless there is anything repugnant in the subject or context:

- i. "District" means an area declared as jurisdiction of particular "District Municipal Corporation" unless additional area is also included in the BIDDING DOCUMENT;
- ii. "Procuring Agency" means the SSWMB;
- iii. "Representative" means The Employee / committee notified or engaged by SSWMB for Monitoring this job;
- iv. "Scope of the work under this contract means" Lifting transportation and disposal of all types of garbage / solid waste (excluding hazardous waste) and including but not limited to domestic / commercial garbage, rubbish, shrub, tree cutting of any condition and from (dry, semi dry or wet) as well as old debris mixed with garbage and inseparable from its etc from Garbage Transfer Stations (whether located within DMC East Jurisdiction or outside its limits but used by DMC East as formal or informal, temporary or permanent GTS or intermediate point for transfer of Garbage) to landfill sites (Jam Chakro and Gond Pass) including loading / unloading haulage / transportation and weightage from the designated weighbridges.
- v. "SSWMB" means Sindh Solid Waste Management Board;
- vi. "Transportation of Garbage from any site in the district to Landfill Sites" means lifting, transportation and disposal of all types of garbage / solid waste and includes but not limited to domestic / commercial garbage, rubbish, shrub, tree cutting of any condition and from (dry, semi dry or wet) as well as debris mixed with garbage and inseparable from it etc, from any site in the concerned district to Landfill Sites (Gond Pass / Jam Chakro), including loading / unloading, haulage / transportation and weightage from the designated weighbridges;
- vii. Words "Bid Security and Earnest Money" are used synonymously and have same meaning;
- viii. Words "Performance Security and Security Deposit" are used synonymously and have same meaning;
- ix. Words "Contractor and Bidder" are used synonymously and mean the contractor or bidder, individual, firm or company who shows willingness to perform the 'work', on the rate quoted by him or his firm / company, on the terms and conditions set out in the NIT, this document as well as Sindh Public Procurement Rules 2010 (amended 2017);
- x. Words "Tender and Bid" are used synonymously and mean the Tender or Bid submitted by the individual Contractor, firm or Company;
- xi. Words "Garbage" and Solid Waste are used synonymously and mean all types of waste and includes but not limited to domestic / commercial garbage, rubbish, shrub, tree cutting of any condition and from (dry, semi dry or wet) as well as old debris mixed with garbage and inseparable from it etc.

1.11 Measurement of solid waste

All sort of Solid Waste as described in clause 1.8 & 1.10(iv) (Scope) above and also defined at 1.10.xi above shall be quantified / measured in tons (one metric ton / 1000 kg) for the respective load as per BOQ item of work. The solid waste shall be weighed on the independent weight bridge, designated / authorized or installed for the purpose by SSWMB. The cost of

weightage (weighbridge) of garbage shall be borne by the contractor. Any cost or fee for disposal of garbage at Landfill site shall be borne by the contractor.

1.12 Verification of weight of solid waste

Only weight slip of Solid Waste (Garbage) issued by designated weighbridge duly verified by the authorized officer / committee constituted for the purpose shall be considered for payment.

1.13 Minimum lifting capacity

The contractor shall be required to lift, transport and dispose of, whatever quantity of Solid Waste / Garbage is available, on the different GTS / collection points or accumulated Solid Waste at temporary collection points / temporary or permanent GTSs / points of DMC East to designated landfill sites. Authorized officer (s) of SSWMB / DMC / Monitoring Committee constituted for the purpose shall designate the sites and intimate the contractor the schedule as well as the points from where to collect and lift the garbage and transport to Landfill site for disposal. The Contractor shall be bound to observe the minimum target quantity and schedule set by Authorized officer (s) of SSWMB / DMC / Monitoring Committee constituted for the purpose.

1.14 Failures to achieve minimum lifting target

The contractor shall be bound to arrange & manage lifting of routine garbage / solid waste as described above in clause 1.13 above for lifting / transportation of solid waste per day. In the event of failure to achieve the above target, a Penalty of Rs. 50,000/- per day for 1st three days of failure and Rs. 100,000/- of further period of failure shall be imposed subject to a maximum of 1% of the bid amount; thereafter the contract shall stand cancelled.

1.15 Rate analysis

The contractor shall provide, along with his tender / bid, analysis for his quoted rates for the items of work mentioned in BOQ including hiring charges of machinery, overhead cost of POL and other incidental charges, if any. Failure to provide the rate analysis shall render the tender / bid non responsive & shall be summarily rejected.

1.16 Rates to be inclusive of all taxes

The tender rate shall be inclusive of all applicable taxes and incidental charges (e.g. weigh bridge charges, LFS charges etc.) in connection with the work.

2.1 Contactor's failure to start the work.

If the contractor fails to commence the work within 07 days after the work order issued to him, the Earnest Money (Bid Security) shall be forfeited and the work order shall be treated as cancelled.

2.2 Arrangement of water

The contractor should make his own arrangement of water, if required for the work execution as well as drinking and nothing will be paid / deducted for the same by Procuring Agency in the matter.

2.3 No alteration / addition in BOQ

No alteration or addition shall be made by the contractor in schedule of quantities. The rate must be filled in ink or typed out and mentioned in figure as well as words clearly and legibly in columns provided in schedule of quantities. Any correction must be initialed by the bidder. Any tender which does not comply with the terms and conditions shall be liable to be summarily rejected and shall not be considered.

2.4 Taxation

The rate and price in the tender by the contractor shall include all business tax, income tax, SRB tax and all other taxes that may be levied by the government according to the laws and regulation in being as of the date 28 days prior to the closing date of submission of tenders or levied from time to time during the contract. However, nothing in this document shall relieve the contractor from his responsibilities to pay any tax that may be levied by the government on the receivable amount / profit made to him in respect of the work during currency of the contract.

2.5 Tender validity

Tender shall remain valid for 90 days after the opening date of tender.

2.6 Security:

i. Bid Security (Earnest Money)

- The tender must be accompanied with **Bid Security (Earnest Money) equivalent to 2% of the contract price on the following form**
- *Bank draft / pay order or Bank Guarantee drawn of an approved scheduled bank in favour of SSWMB.*
- The Bid Security (Earnest Money) shall be calculated on the basis of Rate offered on average of 1400 Tons Garbage per day for 365 days The Bid Security (Earnest Money) shall be returned to all bidders as soon as the contract is awarded to the Lowest Evaluated Bidder.

$$\text{Bid Security} = \text{PKR} = 1400 \times 365 \times \text{Quoted Rate per Ton} \times 2\%$$

ii. Performance Security (Security Deposit)

- The total amount of **Performance Security (Security Deposit)** shall be 10% of the contract price approved by the Procuring Agency.
- The successful bidder shall deposit 2% Performance Security (Security Deposit) at the time of award of contract / agreement. The remaining 08% Performance Security (Security Deposit) shall be deducted from each running bill of the contractor.

2.7 Tender to be non responsive without prescribed Bid Security (Earnest Money)

Any tender which is not accompanied with required **Bid Security (Earnest Money)**, in the shape described above, shall be rejected by the Procuring Agency as non responsive.

2.8 Sufficiency of tender

Each contractor / bidder shall be deemed to have satisfied himself before tendering to the correctness and sufficiency of his tender as for as to cover his entire obligation.

2.9 Refund of Security deposit

The Performance Security (Security Deposit) of the successful bidder deposited at the time of award of the contract and also deducted during the contract period, shall be refunded after three month from the date of expiry of contract.

3.0 Conditional offers

All contractors / bidders are hereby cautioned that tenders with conditional offer or deviation from the conditions of contract or other requirements stipulated in their tender documents, shall be similarly rejected as non responsive and shall not be considered.

3.1 Damage to person and property

The contractors / bidders shall indemnify the Procuring Agency against all losses and claims in respect of;

- a) Death or injury to any persons due to accidents
- b) Loss or damage to any vehicle or property which might occur due to accident or in consequences of the execution of work and against all claims, proceeding, damages, costs, charges and expenses whatsoever in respect thereof or in relation thereto.

3.2 Canvassing in respect of tenders

Canvassing in connection with tenders is strictly prohibited and the tenders / bids submitted by contractor / bidder who resorts to canvassing will be liable to rejection.

3.3 Rate / Tenders amount to be quoted in figures as well as in words

The Rates quoted by the contractor / bidder shall be written in figure as well as in words in English language clearly.

3.4 Each paper of tender documents should be signed by the contractors

The contractor / bidder should sign each page of the tender documents as well as correction and overwriting before submitting his tender.

3.5 Minimum requirement of plant / machinery / tools equipment for the purpose of execution of works under this contract

1.	Loaders / Shovel: -----	03-05
2.	Dump Trucks (10-12 wheelers) with high walls:	16-20
3.	Excavator: -----	01 (as and when required)

The minimum requirement is given just to provide a guideline to the contractor / bidder, so that they can understand the work assignment under this contract.

3.6 Variations in quantities

- The quantities of various item of work given in BOQ are tentative and may vary.
- If need arises, the Procuring Agency may ask the contractor / bidder to carry out the assigned work in adjacent district, but this shall be with mutual agreement between both parties. However, the payment shall be made as per the lowest rate of the work awarded for that district.
- SSWMB shall not entertain any claim, at any stage, by the contractor for non-availability of fore-casted volume of garbage for lifting and transportation from district to LFS.

3.7 Work during late hours or in emergencies

Contractors are hereby cautioned that they may be called for the work during holidays, in late hours and in emergency on directives of SSWMB.

3.8 Period of contract

One year from the issuance of work order, extendable for another month on the same rate without prejudice to the terms and conditions of the contract. However, if at any time, during the currency of contract, the continuation of the same becomes difficult or impossible due to factors beyond the control of SSWMB in that case the contract may be terminated, without any obligation, on 10 days prior notice from SSWMB to the contractor.

4.0 Procuring Agency's right to accept any tender and to reject any of all tenders

The Procuring Agency reserves the rights to accept or reject any tender / bid or to annual tendering process and reject all tenders at any time prior to award of contract without notice, thereby incurring no liability to the effected tenders or bidders. The Procuring Agency shall not be under any obligations to inform or justify the affected bidders of the ground for Procuring Agency's action.

4.1 The Procuring Agency reserves the right to fix maximum weight of garbage that can be loaded in and transported through a 10-12 wheeler dump truck based on the respective density of garbage. This may be required to discourage lifting and transport of Debris only. In that event any weight above and over the capacity worked out by the density of garbage as noted above shall not be considered for payment and shall be at contractor's own risk and cost.

4.2 The vehicle transporting solid waste from different points to landfill sites shall be completely covered by trampoline and not allowing any kind of spillage during the course of transporting.

Contractor's Signature

Executive Director (Operations-I) SSWMB

**Bill of Quantities
(FORM OF BID)
SSWMB-NIT-10.1/2017-18**

Estimated cost: Open rate Bid Security / Earnest money: 2% equivalent to quoted bid
Contract period: 12 months extendable for another month
Penalty per day: as per clause 1.14 above & Up to 2% of the contract price
Validity period: 90 days Tender fees: Rs. 3,000

**Subject: Transportation of Garbage from GTs & other areas of
District East, Karachi to Landfill Sites
(SSWMB-NIT-10.1/2017-18)**

S#	Description of work (Please read with Clause 1.8 above)	Unit	Qty	Rate per Ton (PKR)	Amount in PKR
01	Loading / Lifting its haulage transportation and unloading / disposal of all types of garbage / solid waste (excluding hazardous waste) and including but not limited to domestic / commercial garbage, rubbish, shrub, tree cutting of any condition and from (fry, semi dry or wet) as well as old debris mixed with garbage and inseparable from its etc from Garbage Transfer Stations (whether located within DMC East Jurisdiction or outside its limits but used by DMC East as formal or informal, temporary or permanent GTS or intermediate point for transfer of Garbage) to landfill sites (Jam Chakro and Gond Pass) including all charges, taxes and the cost of weightage of the Solid waste, LFS fee if any, complete service as directed by the authorized officers / committee according to work plan for the assignment.	Metric Ton (1000 Kg)	1000 - 1400 Tons per day + - 25%		

- Note: - Rate must be quoted both in figure and words otherwise liable to be rejected.
- Overwriting and correction, if any, must be initialed and stamped by the bidder
- I / we hereby quote Rate of Rs. _____ (in figure) Rupees
_____ (in words) per ton for above-mentioned work.
- I / we understand that it is not easy to quantify the weight of garbage / solid waste hence the quantity mentioned above is approximate and can vary + or - 25% or even more.
- I / we have read the standard bidding documents and amendment, if any and agree to abide by all of them.
- I / we have read the standard bidding documents and amendment, if any and agree to abide by all of them.
- I / we understand that this contract shall be governed under SINGLE STAGE - ONE ENVELOPE PROCEDURE as set out in Sindh Public Procurement Rules 2010 (amended 2017). All provisions of Sindh Public Procurement Rules 2010 (amended 2017), whether mentioned in this document or not, shall be applicable to the contract.

- I / We understand that SSWMB reserves the right to ask the contractor to lift, transport and dispose of Garbage (Solid Waste) from any adjacent area of the District in Karachi (not mentioned in the bidding document) to Landfill sites of Karachi.

Contractor Signature _____

Name of the Contractor / Company: _____

Name of the Contractor / Authorized person: _____

Address: _____

Phone: _____

Fax: _____

Email: _____

Date: _____

Seal of the Firm / Company

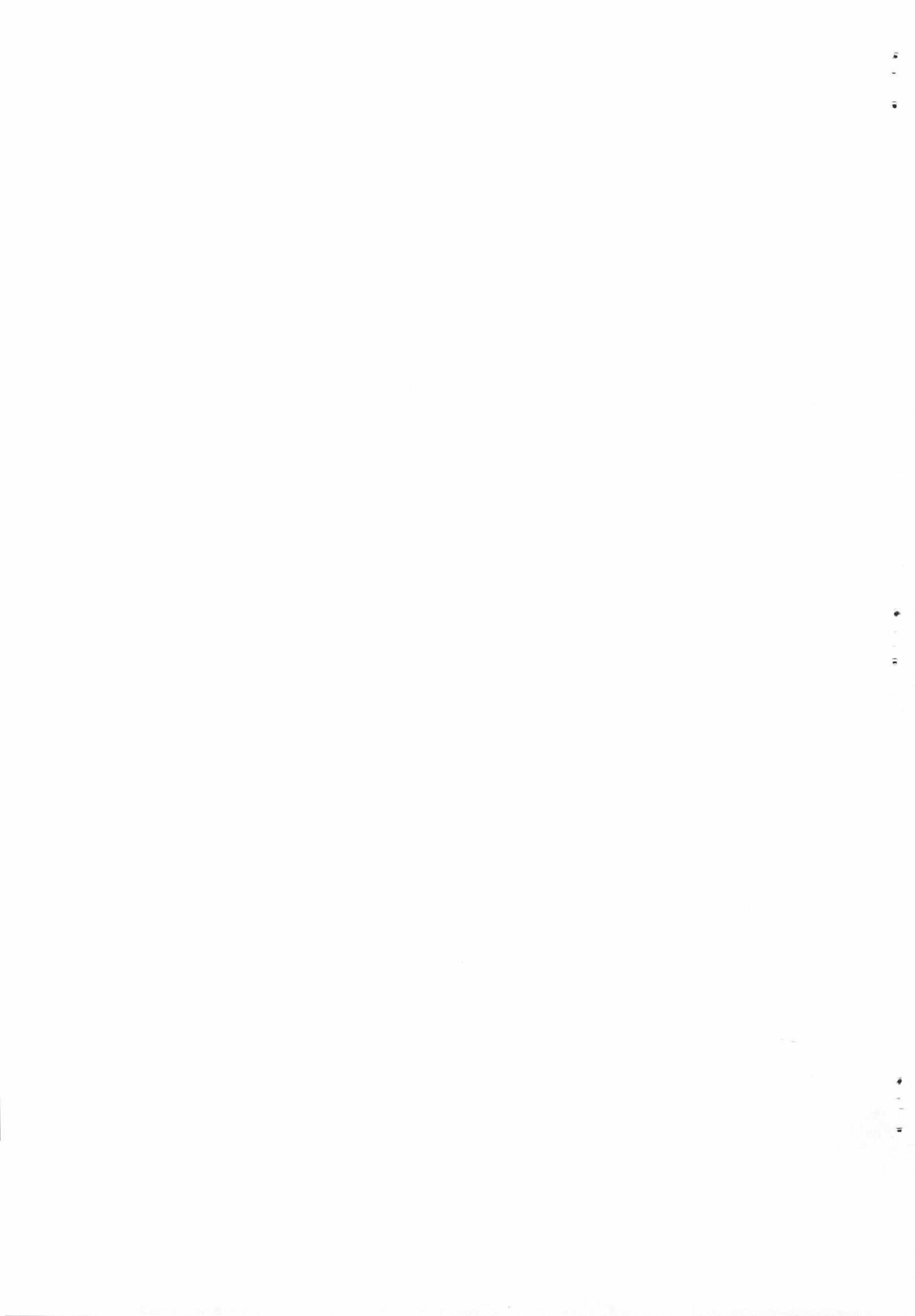



GOVERNMENT OF SINDH



Transportation of Garbage from GTSS & other areas of District South, Karachi to Landfill Sites

Tender Reference: SSWMB - NIT - 10.2 /2017-18

BIDDING DOCUMENTS

Procuring Agency:

Sindh Solid Waste Management Board

Bungalow # 13, Al-Hamra Housing Society, Shaheed e Millat Road, Karachi

Ph # 021-9933 3704-06, Fax # 021-9933 3707 Email Address: info@sswmb.gos.pk website: www.sswmb.gos.pk



NOTICE INVITING TENDER
(SSWMB/NIT-9 & 10/ 2017-18)

Sindh Solid Waste Management Board (SSWMB) invites sealed bids from interested Contractors / Firms for carrying out the Works / Services mentioned below under **SINGLE STAGE – ONE ENVELOPE PROCEDURE**

TENDER REFERENCE NO.	NAME OF WORK	ESTIMATED COST	TENDER COST
NIT-9/2017-18			
NIT-9	Construction of Boundary Wall on different sites of GTS at Karachi. (Civil Works)	55.141 (Million)	Rs.3000/-
NIT-10/2017-18			
NIT-10.1	Transportation of Garbage from GTSs and other areas of District East, Karachi to Landfill Sites.	Open Rate	Rs.3000/- Each
NIT-10.2	Transportation of Garbage from GTSs and other areas of District South, Karachi to Landfill Sites.		
NIT-10.3	Transportation of Garbage from GTSs and other areas of District West, Karachi to Landfill Sites.		
NIT-10.4	Transportation of Garbage from GTSs and other areas of District Malir, Karachi to Landfill Sites.		

TENDER SCHEDULE

Sr. No.	Schedule	Date & Time	Venue
1.	Issuance of Bidding Documents	From 11-12-2017 to 26-12-2017 (Both days inclusive) during office hours.	Office of Assistant Director (Finance), SSWMB, Bungalow No.13, Al-Hamra Housing Society - Karachi.
2.	Submission of Bids	26-12-2017 at 1500 hours	Committee Room, Sindh Solid Waste Management Board, Bungalow No.13, Al-Hamra Housing Society - Karachi.
3.	Opening of Bids	26-12-2017 at 1530 hours	

- Interested companies can obtain Tender Documents including eligibility criteria upon payment of Tender Document Fee (non-refundable) through **PAY ORDER OR BANK DRAFT** of Pak Rs.3,000/- (for each work) in favor of **Sindh Solid Waste Management Board** as per schedule given above from the office of **Assistant Director (Finance)**, SSWMB during office hours. Alternatively the documents may also be downloaded from the website www.pprasindh.gov.pk or www.sswmb.gos.pk. The companies downloading the documents from the websites must submit Tender Document Fee in the shape of Pay Order or Demand Draft as mentioned above at the time of submission of the bid.
- Bid Security of amount equivalent to 2% of the total quoted bid amount must be attached with the bids.
- Proof of Registration with FBR (NTN / Sales Tax) and Sindh Revenue Board (SRB) is to be submitted with the bids.
- The Bids must be in sealed envelope and submitted **SEPARATE FOR EACH WORK / SERVICES**.
- The envelope must clearly state:
 - Name of the Work (e.g. Transportation of Garbage from GTSs and other areas of District East, Karachi to Landfill Sites and;**
 - Tender Reference Number as mentioned on the bid document (e.g. SSWMB/NIT.10.1/2017-18).**
- In case, the date of opening of bids is declared as a public holiday or non-working day due to force Majeure, the next official working day shall be deemed to be date for issuance, submission and opening of tenders. The time and venue shall remain unchanged.
- Sindh Solid Waste Management Board** shall not be responsible for any cost or expenses incurred by bidding firms and reserves the right to terminate the procurement process at any time subject to relevant provision of SPP Rules, 2010 (Amended 2017).

Deputy Director (Procurement)

Sindh Solid Waste Management Board

Bungalow # 13, Al-Hamra Housing Society, Shaheed e Millat Road, Karachi

Ph # 021-9933 3704-06, Fax # 021-9933 3707 Email Address: info@sswmb.gos.pk website: www.sswmb.gos.pk.

**Transportation of Garbage from GTs and other areas of District South,
Karachi to Landfill Sites.
(SSWMB-NIT-10.2/2017-18)**

TENDER DOCUMENT	
SSWMB-NIT-10.2 (District South)	
Date and time of Submission:	26 th December 2017 latest by 1500 hours
Date and time of opening:	26 th December 2017 at 1530 hours
Place of opening:	Committee Room, Sindh Solid Waste Management Board, Bungalow No. 13, Al-Hamra Housing Society, Shaheed-e-Millat Road – Karachi
Date of issue:	
Name and address of Contractor:	_____
Contractor's Representative	
Name & Signature of Tender Issuing Officer:	
Bid Price:	
Offered Rate Rs. _____ (in words) Rupees _____ Per Ton	
[*Total Bid Amount Rs. _____ (in words) Rupees _____]	
Bid Security 2% of the Total Quoted Bid amount only in the shape of Pay Order / Demand Draft No. _____ Bank / Branch _____ Dated _____	
Performance Security: 10% (2% at the time of agreement + 8% from running & final bill)	
Completion period: 12 months from date of award extendable for another month on the same rate and terms and conditions.	

CHECK LIST / COMPLIANCE TO MINIMUM ELIGIBILITY CRITERIA

(No bid shall be considered unless Minimum Eligibility Criteria is complied)

S. No.	Criteria / Requirement	Compliance Yes / No	Remarks
1.	Registration with FBR (NTN)		
2.	Registration with Sindh Revenue Board (SRB)		
3.	Valid Registration with Pakistan Engineering Council.		
4.	Valid Registration with EPA		
5.	Relevant experience: The bidder should have at least 03 (Three) years experience in handling Solid Waste <p align="center">OR</p> at least 03 (Three) years experience as Contractor of works involving transportation of material as a part of the construction or similar contract.		
6.	Proof of ability to carry out the work i.e. Detail of equipment machinery and transportation /owned/ leased hired by the bidder: i. Registration Books of Loaders / Dumpers owned by the bidders; OR ii. Agreement with Transport supplier along with Registration Number of machinery; OR iii. Any identical proof acceptable by the Procuring Committee.		
7.	List of similar assignments (Transportation of garbage or Construction Contracts) with cost, completed or under execution		
8.	List of litigation (if any) within last three (03) years, nature and status / out come		
9.	Affidavit / undertaking that firm has never been black listed		
10.	Each and Every page of bidding document signed		
11.	Proof of payment of Tender Fee		
12.	Bid Security attached (2% of the Total Quoted Bid amount): - Pay order / Draft / Bank Guarantee - Amount: Rs. -----/- (Rupees -----) - Bank & Branch ----- -----		

Contractor Signature

Name of the Contractor / Company: _____

Name of the Contractor / Authorized person _____

Address: _____

Phone: _____

Fax: _____

Email: _____

Date: _____

Seal of the Firm /

Instruction to bidders

Instruction to bidders and Conditions of Contract

General

1.1 Invitation for tenders

The Sindh Solid Waste Management Board (SSWMB) hereinafter referred as 'Procuring Agency' intends to invite sealed bids from the interested contractors / firms / companies having sufficient experience / resources for the following assignment / work:

Lifting of Garbage (Solid Waste), its Transportation and Disposal from Garbage Transfer Stations (Formal or Informal GTS, Temporary or Permanent) & other areas of DMC South Karachi to Landfill sites (Gondpass and Jam Chakro) as per detailed Scope of Work at 'Section 1.8' below

1.2 This contract shall be governed under SINGLE STAGE – ONE ENVELOPE PROCEDURE as set out in Sindh Public Procurement Rules 2010 (amended 2017).

1.3 All provisions of Sindh Public Procurement Rules 2010 (amended 2017), whether mentioned in this document or not, shall be applicable.

1.4 There is no bar on any contractor to participate in number of tenders i.e. A bidder can participate in tender for One, Two, or even all Four districts mentioned in Tender Notice. However, he will have to submit Separate Bid including Eligibility Criteria, Separate Tender Fee and Separate Bid Security for each District.

1.5 Manner and place, date and time for submission of bidding documents

Sealed bids along with Bid Security and proof of payment of tender fee should be submitted in the tender box of **Sindh Solid Waste Management Board (SSWMB), Bungalow No. 13, Al-Hamra Housing Society, Shaheed-e-Millat Road, Karachi not later than 1500 hours on 26th December 2017**. Bids can also be submitted through registered post or courier but SSWMB shall not be responsible for any delay in submission for whatsoever reasons. Bids submitted by fax, email or any other means except described above shall not be entertained.

1.6 Manner, place, date and time of opening of bids

The Bids shall be opened publically by the Procurement Committee in presence of bidders or their representatives in **Committee Room of Sindh Solid Waste Management Board (SSWMB), Bungalow No. 13, Al-Hamra Housing Society, Shaheed-e-Millat Road, Karachi on 26th December 2017 at 1530 hours**.

In case, the date of opening of bids is declared as a public holiday or non-working day due to force Majeure, the next official working day shall be deemed to be date for issuance, submission and opening of tenders. The time and venue shall remain unchanged.

1.7 Sub-letting of work

The contractor shall not sublet the whole work or any part thereof. The bidder shall be responsible for execution of the contract / providing the services as per BoQ. Subletting shall not be permissible under this contract and shall lead to disqualification. However, hiring of machinery, from open market, for carrying out this work, shall NOT be considered as subletting of the work.

1.8 Scope of work

The work under this contract comprises of Lifting transportation and disposal of all types of garbage / solid waste (excluding hazardous waste) and including but not limited to domestic / commercial garbage, rubbish, shrub, tree cutting of any condition and from (fry, semi dry or wet) as well as old debris mixed with garbage and inseparable from its etc from Garbage Transfer Stations (whether located within DMC South Jurisdiction or outside its limits but used by DMC South as formal or informal, temporary or permanent GTS or intermediate point for transfer of Garbage) to landfill sites (Jam Chakro and Gond Pass) including loading / unloading haulage / transportation and weightage from the designated weighbridges.

1.9 Eligibility Criteria (Please refer to Minimum Eligibility Criteria at page No. 4)

- a) Registration with FBR (NTN);
- b) Registration with Sindh Revenue Board (SRB);
- c) Valid Registration with Pakistan Engineering Council;
- d) Valid Registration with EPA;
- e) Proof of payment of Tender Fee (Separate for Each District);
- f) Proof of payment of prescribed Bid Security (Separate for Each District);
- g) Relevant experience:
The bidder should have at least 03 (Three) years experience in handling Solid Waste

OR

at least 03 (Three) years experience as Contractor of works involving transportation of material (e.g. sand / building material) as a part of the contract.
- h) Proof of ability to carry out the work i.e. Detail of equipment machinery and transportation/owned/ leased hired by the bidder:
Arrangement of at least 03-05 heavy duty Loaders / Shovels and 16-20 (10-12 wheeler) Dump trucks with high walls or equivalent along with allied equipment.
Note:
 - i. The proof can be either copies of registration papers of vehicles or an agreement with Transportation Vehicle Supplier showing Registration Number, type and capacity of vehicles, which shall be made available specifically for this district work.
 - ii. The same vehicle can't be quoted for work of another district i.e. same vehicle will not be counted for more than one district to undertake this work in the shape of arrangement;

- iii. *Any vehicle quoted by the contractor in any previous garbage lifting & transportation contract of SSWMB can't be re-quoted before expiry of that contract;*
- iv. *SSWMB reserves the right to carry out further checks to verify the ability of the bidder to accomplish the assignment.*

- i) List of similar assignments with cost (mention number of projects) completed or under execution;
- j) List of litigation (if any) within last three (03) years, nature and status / outcome;
- k) Affidavit / Undertaking that firm has never been black listed;

1.10 Definition and interpretation

In this as document following words and expressions shall have the meaning hereby assigned to them, unless there is anything repugnant in the subject or context:

- i. "District" means an area declared as jurisdiction of particular "District Municipal Corporation" unless additional area is also included in the BIDDING DOCUMENT;
- ii. "Procuring Agency" means the SSWMB;
- iii. "Representative" means The Employee / committee notified or engaged by SSWMB for Monitoring this job;
- iv. "Scope of the work under this contract means" Lifting transportation and disposal of all types of garbage / solid waste (excluding hazardous waste) and including but not limited to domestic / commercial garbage, rubbish, shrub, tree cutting of any condition and from (fry, semi dry or wet) as well as old debris mixed with garbage and inseparable from its etc from Garbage Transfer Stations (whether located within DMC South Jurisdiction or outside its limits but used by DMC South as formal or informal, temporary or permanent GTS or intermediate point for transfer of Garbage) to landfill sites (Jam Chakro and Gond Pass) including loading / unloading haulage / transportation and weightage from the designated weighbridges.
- v. "SSWMB" means Sindh Solid Waste Management Board;
- vi. "Transportation of Garbage from any site in the district to Landfill Sites" means lifting, transportation and disposal of all types of garbage / solid waste and includes but not limited to domestic / commercial garbage, rubbish, shrub, tree cutting of any condition and from (dry, semi dry or wet) as well as debris mixed with garbage and inseparable from it etc, from any site in the concerned district to Landfill Sites (Gond Pass / Jam Chakro), including loading / unloading, haulage / transportation and weightage from the designated weighbridges;
- vii. Words "Bid Security and Earnest Money" are used synonymously and have same meaning;
- viii. Words "Performance Security and Security Deposit" are used synonymously and have same meaning;
- ix. Words "Contractor and Bidder" are used synonymously and mean the contractor or bidder, individual, firm or company who shows willingness to perform the 'work', on the rate quoted by him or his firm / company, on the terms and conditions set out in the NIT, this document as well as Sindh Public Procurement Rules 2010 (amended 2017);
- x. Words "Tender and Bid" are used synonymously and mean the Tender or Bid submitted by the individual Contractor, firm or Company;
- xi. Words "Garbage" and Solid Waste are used synonymously and mean all types of waste and includes but not limited to domestic / commercial garbage, rubbish, shrub, tree cutting of any condition and from (dry, semi dry or wet) as well as old debris mixed with garbage and inseparable from it etc.

1.11 Measurement of solid waste

All sort of Solid Waste as described in clause 1.8 & 1.10(iv) (Scope) above and also defined at 1.10.xi above shall be quantified / measured in tons (one metric ton / 1000 kg) for the respective load as per BOQ item of work. The solid waste shall be weighed on the independent weight bridge, designated / authorized or installed for the purpose by SSWMB. The cost of

weightage (weighbridge) of garbage shall be borne by the contractor. Any cost or fee for disposal of garbage at Landfill site shall be borne by the contractor.

1.12 Verification of weight of solid waste

Only weight slip of Solid Waste (Garbage) issued by designated weighbridge duly verified by the authorized officer / committee constituted for the purpose shall be considered for payment.

1.13 Minimum lifting capacity

The contractor shall be required to lift, transport and dispose of, whatever quantity of Solid Waste / Garbage is available, on the different GTS / collection points or accumulated Solid Waste at temporary collection points / temporary or permanent GTSs / points of DMC South to designated landfill sites. Authorized officer (s) of SSWMB / DMC / Monitoring Committee constituted for the purpose shall designate the sites and intimate the contractor the schedule as well as the points from where to collect and lift the garbage and transport to Landfill site for disposal. The Contractor shall be bound to observe the minimum target quantity and schedule set by Authorized officer (s) of SSWMB / DMC / Monitoring Committee constituted for the purpose.

1.14 Failures to achieve minimum lifting target

The contractor shall be bound to arrange & manage lifting of routine garbage / solid waste as described above in clause 1.13 above for lifting / transportation of solid waste per day. In the event of failure to achieve the above target, a Penalty of Rs. 50,000/- per day for 1st three days of failure and Rs. 100,000/- of further period of failure shall be imposed subject to a maximum of 1% of the bid amount; thereafter the contract shall stand cancelled.

1.15 Rate analysis

The contractor shall provide, along with his tender / bid, analysis for his quoted rates for the items of work mentioned in BOQ including hiring charges of machinery, overhead cost of POL and other incidental charges,, if any. Failure to provide the rate analysis shall render the tender / bid non responsive & shall be summarily rejected.

1.16 Rates to be inclusive of all taxes

The tender rate shall be inclusive of all applicable taxes and incidental charges (e.g. weigh bridge charges, LFS charges etc.) in connection with the work.

2.1 Contactor's failure to start the work.

If the contractor fails to commence the work within 07 days after the work order issued to him, the Earnest Money (Bid Security) shall be forfeited and the work order shall be treated as cancelled.

2.2 Arrangement of water

The contractor should make his own arrangement of water, if required for the work execution as well as drinking and nothing will be paid / deducted for the same by Procuring Agency in the matter.

2.3 No alteration / addition in BOQ

No alteration or addition shall be made by the contractor in schedule of quantities. The rate must be filled in ink or typed out and mentioned in figure as well as words clearly and legibly in columns provided in schedule of quantities. Any correction must be initialed by the bidder. Any tender which does not comply with the terms and conditions shall be liable to be summarily rejected and shall not be considered.

2.4 Taxation

The rate and price in the tender by the contractor shall include all business tax, income tax, SRB tax and all other taxes that may be levied by the government according to the laws and regulation in being as of the date 28 days prior to the closing date of submission of tenders or levied from time to time during the contract. However, nothing in this document shall relieve the contractor from his responsibilities to pay any tax that may be levied by the government on the receivable amount / profit made to him in respect of the work during currency of the contract.

2.5 Tender validity

Tender shall remain valid for 90 days after the opening date of tender.

2.6 Security:

i. Bid Security (Earnest Money)

- The tender must be accompanied with **Bid Security (Earnest Money) equivalent to 2% of the contract price on the following form**
- *Bank draft / pay order or Bank Guarantee drawn of an approved scheduled bank in favour of SSWMB.*
- The Bid Security (Earnest Money) shall be calculated on the basis of Rate offered on average of 1500 Tons Garbage per day for 365 days The Bid Security (Earnest Money) shall be returned to all bidders as soon as the contract is awarded to the Lowest Evaluated Bidder.

$$\text{Bid Security} = \text{PKR} = 1500 \times 365 \times \text{Quoted Rate per Ton} \times 2\%$$

ii. Performance Security (Security Deposit)

- The total amount of **Performance Security (Security Deposit)** shall be 10% of the contract price approved by the Procuring Agency.
- The successful bidder shall deposit 2% Performance Security (Security Deposit) at the time of award of contract / agreement. The remaining 08% Performance Security (Security Deposit) shall be deducted from each running bill of the contractor.

2.7 Tender to be non responsive without prescribed Bid Security (Earnest Money)

Any tender which is not accompanied with required **Bid Security (Earnest Money)**, in the shape described above, shall be rejected by the Procuring Agency as non responsive.

2.8 Sufficiency of tender

Each contractor / bidder shall be deemed to have satisfied himself before tendering to the correctness and sufficiency of his tender as for as to cover his entire obligation.

2.9 Refund of Security deposit

The Performance Security (Security Deposit) of the successful bidder deposited at the time of award of the contract and also deducted during the contract period, shall be refunded after three month from the date of expiry of contract.

3.0 Conditional offers

All contractors / bidders are hereby cautioned that tenders with conditional offer or deviation from the conditions of contract or other requirements stipulated in their tender documents, shall be similarly rejected as non responsive and shall not be considered.

3.1 Damage to person and property

The contractors / bidders shall indemnify the Procuring Agency against all losses and claims in respect of;

- a) Death or injury to any persons due to accidents
- b) Loss or damage to any vehicle or property which might occur due to accident or in consequences of the execution of work and against all claims, proceeding, damages, costs, charges and expenses whatsoever in respect thereof or in relation thereto.

3.2 Canvassing in respect of tenders

Canvassing in connection with tenders is strictly prohibited and the tenders / bids submitted by contractor / bidder who resorts to canvassing will be liable to rejection.

3.3 Rate / Tenders amount to be quoted in figures as well as in words

The Rates quoted by the contractor / bidder shall be written in figure as well as in words in English language clearly.

3.4 Each paper of tender documents should be signed by the contractors

The contractor / bidder should sign each page of the tender documents as well as correction and overwriting before submitting his tender.

3.5 Minimum requirement of plant / machinery / tools equipment for the purpose of execution of works under this contract

1.	Loaders / Shovel: -----	03-05
2.	Dump Trucks (10-12 wheelers) with high walls:	16-20
3.	Excavator: -----	01 (as and when required)

The minimum requirement is given just to provide a guideline to the contractor / bidder, so that they can understand the work assignment under this contract.

3.6 Variations in quantities

- The quantities of various item of work given in BOQ are tentative and may vary.
- If need arises, the Procuring Agency may ask the contractor / bidder to carry out the assigned work in adjacent district, but this shall be with mutual agreement between both parties. However, the payment shall be made as per the lowest rate of the work awarded for that district.
- SSWMB shall not entertain any claim, at any stage, by the contractor for non-availability of fore-casted volume of garbage for lifting and transportation from district to LFS.

3.7 Work during late hours or in emergencies

Contractors are hereby cautioned that they may be called for the work during holidays, in late hours and in emergency on directives of SSWMB.

3.8 Period of contract

One year from the issuance of work order, extendable for another month on the same rate without prejudice to the terms and conditions of the contract. However, if at any time, during the currency of contract, the continuation of the same becomes difficult or impossible due to factors beyond the control of SSWMB in that case the contract may be terminated, without any obligation, on 10 days prior notice from SSWMB to the contractor.

4.0 Procuring Agency's right to accept any tender and to reject any of all tenders

The Procuring Agency reserves the rights to accept or reject any tender / bid or to annual tendering process and reject all tenders at any time prior to award of contract without notice, thereby incurring no liability to the effected tenders or bidders. The Procuring Agency shall not be under any obligations to inform or justify the affected bidders of the ground for Procuring Agency's action.

4.1 The Procuring Agency reserves the right to fix maximum weight of garbage that can be loaded in and transported through a 10-12 wheeler dump truck based on the respective density of garbage. This may be required to discourage lifting and transport of Debris only. In that event any weight above and over the capacity worked out by the density of garbage as noted above shall not be considered for payment and shall be at contractor's own risk and cost.

4.2 The vehicle transporting solid waste from different points to landfill sites shall be completely covered by trampoline and not allowing any kind of spillage during the course of transporting.

Contractor's Signature

Executive Director (Operations-I) SSWMB

**Bill of Quantities
(FORM OF BID)
SSWMB-NIT-10.2/2017-18**

Estimated cost: Open rate Bid Security / Earnest money: 2% equivalent to quoted bid
Contract period: 12 months extendable for another month
Penalty per day: as per clause 1.14 above & Up to 2% of the contract price
Validity period: 90 days Tender fees: Rs. 3,000

**Subject: Transportation of Garbage from GTs & other areas of
District South, Karachi to Landfill Sites
(SSWMB-NIT-10.2/2017-18)**

S#	Description of work (Please read with Clause 1.8 above)	Unit	Qty	Rate per Ton (PKR)	Amount in PKR
01	Loading / Lifting its haulage transportation and unloading / disposal of all types of garbage / solid waste (excluding hazardous waste) and including but not limited to domestic / commercial garbage, rubbish, shrub, tree cutting of any condition and from (fry, semi dry or wet) as well as old debris mixed with garbage and inseparable from its etc from Garbage Transfer Stations (whether located within DMC South Jurisdiction or outside its limits but used by DMC South as formal or informal, temporary or permanent GTS or intermediate point for transfer of Garbage) to landfill sites (Jam Chakro and Gond Pass) including all charges, taxes and the cost of weightage of the Solid waste, LFS fee if any, complete service as directed by the authorized officers / committee according to work plan for the assignment.	Metric Ton (1000 Kg)	1000 - 1500 Tons per day + - 25%		

- Note: - Rate must be quoted both in figure and words otherwise liable to be rejected.
- Overwriting and correction, if any, must be initialed and stamped by the bidder
- I / we hereby quote Rate of Rs. _____ (in figure) Rupees
_____ (in words) per ton for above-mentioned work.
- I / we understand that it is not easy to quantify the weight of garbage / solid waste hence the quantity mentioned above is approximate and can vary + or - 25% or even more.
- I / we have read the standard bidding documents and amendment, if any and agree to abide by all of them.
- I / we have read the standard bidding documents and amendment, if any and agree to abide by all of them.
- I / we understand that this contract shall be governed under SINGLE STAGE - ONE ENVELOPE PROCEDURE as set out in Sindh Public Procurement Rules 2010 (amended 2017). All provisions of Sindh Public Procurement Rules 2010 (amended 2017), whether mentioned in this document or not, shall be applicable to the contract.

- I / We understand that SSWMB reserves the right to ask the contractor to lift, transport and dispose of Garbage (Solid Waste) from any adjacent area of the District in Karachi (not mentioned in the bidding document) to Landfill sites of Karachi.

Contractor Signature _____

Name of the Contractor / Company: _____

Name of the Contractor / Authorized person: _____

Address: _____

Phone: _____

Fax: _____

Email: _____

Date: _____

Seal of the Firm / Company





GOVERNMENT OF SINDH



**Transportation of Garbage from GTs & other areas of District
West, Karachi to Landfill Sites**

Tender Reference: SSWMB - NIT - 10.3 /2017-18

BIDDING DOCUMENTS

Procuring Agency:

Sindh Solid Waste Management Board

Bungalow # 13, Al-Hamra Housing Society, Shaheed e Millat Road, Karachi

Ph # 021-9933 3704-06, Fax # 021-9933 3707 Email Address: info@sswmb.gos.pk website: www.sswmb.gos.pk



NOTICE INVITING TENDER
(SSWMB/NIT-9 & 10/ 2017-18)

Sindh Solid Waste Management Board (SSWMB) invites sealed bids from interested Contractors / Firms for carrying out the Works / Services mentioned below under *SINGLE STAGE – ONE ENVELOPE PROCEDURE*

TENDER REFERENCE NO.	NAME OF WORK	ESTIMATED COST	TENDER COST
NIT-9/2017-18			
NIT-9	Construction of Boundary Wall on different sites of GTS at Karachi. (Civil Works)	55.141 (Million)	Rs.3000/-
NIT-10/2017-18			
NIT-10.1	Transportation of Garbage from GTSs and other areas of District East, Karachi to Landfill Sites.	Open Rate	Rs.3000/- Each
NIT-10.2	Transportation of Garbage from GTSs and other areas of District South, Karachi to Landfill Sites.		
NIT-10.3	Transportation of Garbage from GTSs and other areas of District West, Karachi to Landfill Sites.		
NIT-10.4	Transportation of Garbage from GTSs and other areas of District Malir, Karachi to Landfill Sites.		

TENDER SCHEDULE

Sr. No.	Schedule	Date & Time	Venue
1.	Issuance of Bidding Documents	From 11-12-2017 to 26-12-2017 (Both days inclusive) during office hours.	Office of Assistant Director (Finance), SSWMB, Bungalow No.13, Al-Hamra Housing Society - Karachi.
2.	Submission of Bids	26-12-2017 at 1500 hours	Committee Room, Sindh Solid Waste Management Board, Bungalow No.13, Al-Hamra Housing Society - Karachi.
3.	Opening of Bids	26-12-2017 at 1530 hours	

- Interested companies can obtain Tender Documents including eligibility criteria upon payment of Tender Document Fee (non-refundable) through **PAY ORDER OR BANK DRAFT** of Pak Rs.3,000/- (for each work) in favor of **Sindh Solid Waste Management Board** as per schedule given above from the office of **Assistant Director (Finance)**, SSWMB during office hours. Alternatively the documents may also be downloaded from the website www.pprasindh.gov.pk or www.sswmb.gos.pk. The companies downloading the documents from the websites must submit Tender Document Fee in the shape of Pay Order or Demand Draft as mentioned above at the time of submission of the bid.
- Bid Security of amount equivalent to 2% of the total quoted bid amount must be attached with the bids.
- Proof of Registration with FBR (NTN / Sales Tax) and Sindh Revenue Board (SRB) is to be submitted with the bids.
- The Bids must be in sealed envelope and submitted **SEPARATE FOR EACH WORK / SERVICES**.
- The envelope must clearly state:
 - Name of the Work (e.g. Transportation of Garbage from GTSs and other areas of District East, Karachi to Landfill Sites and;**
 - Tender Reference Number as mentioned on the bid document (e.g. SSWMB/NIT.10.1/2017-18).**
- In case, the date of opening of bids is declared as a public holiday or non-working day due to force Majeure, the next official working day shall be deemed to be date for issuance, submission and opening of tenders. The time and venue shall remain unchanged.
- Sindh Solid Waste Management Board** shall not be responsible for any cost or expenses incurred by bidding firms and reserves the right to terminate the procurement process at any time subject to relevant provision of SPP Rules, 2010 (Amended 2017).

Deputy Director (Procurement)

Sindh Solid Waste Management Board

Bungalow # 13, Al-Hamra Housing Society, Shaheed e Millat Road, Karachi

Ph # 021-9933 3704-06, Fax # 021-9933 3707 Email Address: info@sswmb.gos.pk website: www.sswmb.gos.pk.

**Transportation of Garbage from GTs and other areas of District West,
Karachi to Landfill Sites.
(SSWMB-NIT-10.3/2017-18)**

TENDER DOCUMENT	
SSWMB-NIT-10.3 (District West)	
Date and time of Submission:	26 th December 2017 latest by 1500 hours
Date and time of opening:	26 th December 2017 at 1530 hours
Place of opening:	Committee Room, Sindh Solid Waste Management Board, Bungalow No. 13, Al-Hamra Housing Society, Shaheed-e-Millat Road - Karachi
Date of issue:	
Name and address of Contractor:	_____ _____
Contractor's Representative	
Name & Signature of Tender Issuing Officer:	
Bid Price:	
Offered Rate Rs. _____ (in words) Rupees _____ Per Ton	
[*Total Bid Amount Rs. _____	
(in words) Rupees _____]	
Bid Security 2% of the Total Quoted Bid amount only in the shape of Pay Order / Demand Draft No. _____ Bank / Branch _____ Dated _____	
Performance Security: 10% (2% at the time of agreement + 8% from running & final bill)	
Completion period: 12 months from date of award extendable for another month on the same rate and terms and conditions.	

CHECK LIST / COMPLIANCE TO MINIMUM ELIGIBILITY CRITERIA

(No bid shall be considered unless Minimum Eligibility Criteria is complied)

S. No.	Criteria / Requirement	Compliance Yes / No	Remarks
1.	Registration with FBR (NTN)		
2.	Registration with Sindh Revenue Board (SRB)		
3.	Valid Registration with Pakistan Engineering Council		
4.	Valid Registration with EPA		
5.	Relevant experience: The bidder should have at least 03 (Three) years experience in handling Solid Waste OR at least 03 (Three) years experience as Contractor of works involving transportation of material as a part of the construction or similar contract.		
6.	Proof of ability to carry out the work i.e. Detail of equipment machinery and transportation /owned/ leased hired by the bidder: i. Registration Books of Loaders / Dumpers owned by the bidders; OR ii. Agreement with Transport supplier along with Registration Number of machinery; OR iii. Any identical proof acceptable by the Procuring Committee.		
7.	List of similar assignments (Transportation of garbage or Construction Contracts) with cost, completed or under execution		
8.	List of litigation (if any) within last three (03) years, nature and status / out come		
9.	Affidavit / undertaking that firm has never been black listed		
10.	Each and Every page of bidding document signed		
11.	Proof of payment of Tender Fee		
12.	Bid Security attached (2% of the Total Quoted Bid amount): - Pay order / Draft / Bank Guarantee - Amount: Rs. -----/- (Rupees -----) - Bank & Branch ----- -----		

Contractor Signature

Name of the Contractor / Company: _____

Name of the Contractor / Authorized person _____

Address: _____

Phone: _____

Fax: _____

Email: _____

Date: _____

Seal of the Firm /

Instruction to bidders

Instruction to bidders and Conditions of Contract

General

1.1 Invitation for tenders

The Sindh Solid Waste Management Board (SSWMB) hereinafter referred as 'Procuring Agency' intends to invite sealed bids from the interested contractors / firms / companies having sufficient experience / resources for the following assignment / work:

Lifting of Garbage (Solid Waste), its Transportation and Disposal from Garbage Transfer Stations (Formal or Informal GTS, Temporary or Permanent) & other areas of DMC West Karachi to Landfill sites (Gondpass and Jam Chakro) as per detailed Scope of Work at 'Section 1.8' below

1.2 This contract shall be governed under SINGLE STAGE – ONE ENVELOPE PROCEDURE as set out in Sindh Public Procurement Rules 2010 (amended 2017).

1.3 All provisions of Sindh Public Procurement Rules 2010 (amended 2017), whether mentioned in this document or not, shall be applicable.

1.4 There is no bar on any contractor to participate in number of tenders i.e. A bidder can participate in tender for One, Two, or even all Four districts mentioned in Tender Notice. However, he will have to submit Separate Bid including Eligibility Criteria, Separate Tender Fee and Separate Bid Security for each District.

1.5 Manner and place, date and time for submission of bidding documents

Sealed bids along with Bid Security and proof of payment of tender fee should be submitted in the tender box of **Sindh Solid Waste Management Board (SSWMB), Bungalow No. 13, Al-Hamra Housing Society, Shaheed-e-Millat Road, Karachi not later than 1500 hours on 26th December 2017**. Bids can also be submitted through registered post or courier but SSWMB shall not be responsible for any delay in submission for whatsoever reasons. Bids submitted by fax, email or any other means except described above shall not be entertained.

1.6 Manner, place, date and time of opening of bids

The Bids shall be opened publically by the Procurement Committee in presence of bidders or their representatives in **Committee Room of Sindh Solid Waste Management Board (SSWMB), Bungalow No. 13, Al-Hamra Housing Society, Shaheed-e-Millat Road, Karachi on 26th December 2017 at 1530 hours**.

In case, the date of opening of bids is declared as a public holiday or non-working day due to force Majeure, the next official working day shall be deemed to be date for issuance, submission and opening of tenders. The time and venue shall remain unchanged.

1.7 Sub-letting of work

The contractor shall not sublet the whole work or any part thereof. The bidder shall be responsible for execution of the contract / providing the services as per BoQ. Subletting shall not be permissible under this contract and shall lead to disqualification. However, hiring of machinery, from open market, for carrying out this work, shall NOT be considered as subletting of the work.

1.8 Scope of work

The work under this contract comprises of Lifting transportation and disposal of all types of garbage / solid waste (excluding hazardous waste) and including but not limited to domestic / commercial garbage, rubbish, shrub, tree cutting of any condition and from (fry, semi dry or wet) as well as old debris mixed with garbage and inseparable from its etc from Garbage Transfer Stations (whether located within DMC West Jurisdiction or outside its limits but used by DMC West as formal or informal, temporary or permanent GTS or intermediate point for transfer of Garbage) to landfill sites (Jam Chakro and Gond Pass) including loading / unloading haulage / transportation and weightage from the designated weighbridges.

1.9 Eligibility Criteria (Please refer to Minimum Eligibility Criteria at page No. 4)

- a) Registration with FBR (NTN);
- b) Registration with Sindh Revenue Board (SRB);
- c) Valid Registration with Pakistan Engineering Council in Category-4.;
- d) Valid Registration with EPA;
- e) Proof of payment of Tender Fee (Separate for Each District);
- f) Proof of payment of prescribed Bid Security (Separate for Each District);
- g) Relevant experience:
The bidder should have at least 03 (Three) years experience in handling Solid Waste

OR

at least 03 (Three) years experience as Contractor of works involving transportation of material (e.g. sand / building material) as a part of the contract.
- h) Proof of ability to carry out the work i.e. Detail of equipment machinery and transportation/owned/ leased hired by the bidder:
Arrangement of at least 03-05 heavy duty Loaders / Shovels and 16-20 (10-12 wheeler) Dump trucks with high walls or equivalent along with allied equipment.
Note:
 - i. *The proof can be either copies of registration papers of vehicles or an agreement with Transportation Vehicle Supplier showing Registration Number, type and capacity of vehicles, which shall be made available specifically for this district work.*
 - ii. *The same vehicle can't be quoted for work of another district i.e. same vehicle will not be counted for more than one district to undertake this work in the shape of arrangement;*

- iii. Any vehicle quoted by the contractor in any previous garbage lifting & transportation contract of SSWMB can't be re-quoted before expiry of that contract;
- iv. SSWMB reserves the right to carry out further checks to verify the ability of the bidder to accomplish the assignment.

- i) List of similar assignments with cost (mention number of projects) completed or under execution;
- j) List of litigation (if any) within last three (03) years, nature and status / outcome;
- k) Affidavit / Undertaking that firm has never been black listed;

1.10 Definition and interpretation

In this as document following words and expressions shall have the meaning hereby assigned to them, unless there is anything repugnant in the subject or context:

- i. "District" means an area declared as jurisdiction of particular "District Municipal Corporation" unless additional area is also included in the BIDDING DOCUMENT;
- ii. "Procuring Agency" means the SSWMB;
- iii. "Representative" means The Employee / committee notified or engaged by SSWMB for Monitoring this job;
- iv. "Scope of the work under this contract means" Lifting transportation and disposal of all types of garbage / solid waste (excluding hazardous waste) and including but not limited to domestic / commercial garbage, rubbish, shrub, tree cutting of any condition and from (dry, semi dry or wet) as well as old debris mixed with garbage and inseparable from its etc from Garbage Transfer Stations (whether located within DMC West Jurisdiction or outside its limits but used by DMC West as formal or informal, temporary or permanent GTS or intermediate point for transfer of Garbage) to landfill sites (Jam Chakro and Gond Pass) including loading / unloading haulage / transportation and weightage from the designated weighbridges.
- v. "SSWMB" means Sindh Solid Waste Management Board;
- vi. "Transportation of Garbage from any site in the district to Landfill Sites" means lifting, transportation and disposal of all types of garbage / solid waste and includes but not limited to domestic / commercial garbage, rubbish, shrub, tree cutting of any condition and from (dry, semi dry or wet) as well as debris mixed with garbage and inseparable from it etc, from any site in the concerned district to Landfill Sites (Gond Pass / Jam Chakro), including loading / unloading, haulage / transportation and weightage from the designated weighbridges;
- vii. Words "Bid Security and Earnest Money" are used synonymously and have same meaning;
- viii. Words "Performance Security and Security Deposit" are used synonymously and have same meaning;
- ix. Words "Contractor and Bidder" are used synonymously and mean the contractor or bidder, individual, firm or company who shows willingness to perform the 'work', on the rate quoted by him or his firm / company, on the terms and conditions set out in the NIT, this document as well as Sindh Public Procurement Rules 2010 (amended 2017);
- x. Words "Tender and Bid" are used synonymously and mean the Tender or Bid submitted by the individual Contractor, firm or Company;
- xi. Words "Garbage" and Solid Waste are used synonymously and mean all types of waste and includes but not limited to domestic / commercial garbage, rubbish, shrub, tree cutting of any condition and from (dry, semi dry or wet) as well as old debris mixed with garbage and inseparable from it etc.

1.11 Measurement of solid waste

All sort of Solid Waste as described in clause 1.8 & 1.10(iv) (Scope) above and also defined at 1.10.xi above shall be quantified / measured in tons (one metric ton / 1000 kg) for the respective load as per BOQ item of work. The solid waste shall be weighed on the independent weight bridge, designated / authorized or installed for the purpose by SSWMB. The cost of

weightage (weighbridge) of garbage shall be borne by the contractor. Any cost or fee for disposal of garbage at Landfill site shall be borne by the contractor.

1.12 Verification of weight of solid waste

Only weight slip of Solid Waste (Garbage) issued by designated weighbridge duly verified by the authorized officer / committee constituted for the purpose shall be considered for payment.

1.13 Minimum lifting capacity

The contractor shall be required to lift, transport and dispose of, whatever quantity of Solid Waste / Garbage is available, on the different GTS / collection points or accumulated Solid Waste at temporary collection points / temporary or permanent GTSs / points of DMC West to designated landfill sites. Authorized officer (s) of SSWMB / DMC / Monitoring Committee constituted for the purpose shall designate the sites and intimate the contractor the schedule as well as the points from where to collect and lift the garbage and transport to Landfill site for disposal. The Contractor shall be bound to observe the minimum target quantity and schedule set by Authorized officer (s) of SSWMB / DMC / Monitoring Committee constituted for the purpose.

1.14 Failures to achieve minimum lifting target

The contractor shall be bound to arrange & manage lifting of routine garbage / solid waste as described above in clause 1.13 above for lifting / transportation of solid waste per day. In the event of failure to achieve the above target, a Penalty of Rs. 50,000/- per day for 1st three days of failure and Rs. 100,000/- of further period of failure shall be imposed subject to a maximum of 1% of the bid amount; thereafter the contract shall stand cancelled.

1.15 Rate analysis

The contractor shall provide, along with his tender / bid, analysis for his quoted rates for the items of work mentioned in BOQ including hiring charges of machinery, overhead cost of POL and other incidental charges,, if any. Failure to provide the rate analysis shall render the tender / bid non responsive & shall be summarily rejected.

1.16 Rates to be inclusive of all taxes

The tender rate shall be inclusive of all applicable taxes and incidental charges (e.g. weigh bridge charges, LFS charges etc.) in connection with the work.

2.1 Contactor's failure to start the work.

If the contractor fails to commence the work within 07 days after the work order issued to him, the Earnest Money (Bid Security) shall be forfeited and the work order shall be treated as cancelled.

2.2 Arrangement of water

The contractor should make his own arrangement of water, if required for the work execution as well as drinking and nothing will be paid / deducted for the same by Procuring Agency in the matter.

2.3 No alteration / addition in BOQ

No alteration or addition shall be made by the contractor in schedule of quantities. The rate must be filled in ink or typed out and mentioned in figure as well as words clearly and legibly in columns provided in schedule of quantities. Any correction must be initialed by the bidder. Any tender which does not comply with the terms and conditions shall be liable to be summarily rejected and shall not be considered.

2.4 Taxation

The rate and price in the tender by the contractor shall include all business tax, income tax, SRB tax and all other taxes that may be levied by the government according to the laws and regulation in being as of the date 28 days prior to the closing date of submission of tenders or levied from time to time during the contract. However, nothing in this document shall relieve the contractor from his responsibilities to pay any tax that may be levied by the government on the receivable amount / profit made to him in respect of the work during currency of the contract.

2.5 Tender validity

Tender shall remain valid for 90 days after the opening date of tender.

2.6 Security:

i. Bid Security (Earnest Money)

- The tender must be accompanied with **Bid Security (Earnest Money) equivalent to 2% of the contract price on the following form**
- *Bank draft / pay order or Bank Guarantee drawn of an approved scheduled bank in favour of SSWMB.*
- The Bid Security (Earnest Money) shall be calculated on the basis of Rate offered on average of 1500 Tons Garbage per day for 365 days The Bid Security (Earnest Money) shall be returned to all bidders as soon as the contract is awarded to the Lowest Evaluated Bidder.

$$\text{Bid Security} = \text{PKR} = 2500 \times 365 \times \text{Quoted Rate per Ton} \times 2\%$$

ii. Performance Security (Security Deposit)

- The total amount of **Performance Security (Security Deposit)** shall be 10% of the contract price approved by the Procuring Agency.
- The successful bidder shall deposit 2% Performance Security (Security Deposit) at the time of award of contract / agreement. The remaining 08% Performance Security (Security Deposit) shall be deducted from each running bill of the contractor.

2.7 Tender to be non responsive without prescribed Bid Security (Earnest Money)

Any tender which is not accompanied with required **Bid Security (Earnest Money)**, in the shape described above, shall be rejected by the Procuring Agency as non responsive.

2.8 Sufficiency of tender

Each contractor / bidder shall be deemed to have satisfied himself before tendering to the correctness and sufficiency of his tender as for as to cover his entire obligation.

2.9 Refund of Security deposit

The Performance Security (Security Deposit) of the successful bidder deposited at the time of award of the contract and also deducted during the contract period, shall be refunded after three month from the date of expiry of contract.

3.0 Conditional offers

All contractors / bidders are hereby cautioned that tenders with conditional offer or deviation from the conditions of contract or other requirements stipulated in their tender documents, shall be similarly rejected as non responsive and shall not be considered.

3.1 Damage to person and property

The contractors / bidders shall indemnify the Procuring Agency against all losses and claims in respect of;

- a) Death or injury to any persons due to accidents
- b) Loss or damage to any vehicle or property which might occur due to accident or in consequences of the execution of work and against all claims, proceeding, damages, costs, charges and expenses whatsoever in respect thereof or in relation thereto.

3.2 Canvassing in respect of tenders

Canvassing in connection with tenders is strictly prohibited and the tenders / bids submitted by contractor / bidder who resorts to canvassing will be liable to rejection.

3.3 Rate / Tenders amount to be quoted in figures as well as in words

The Rates quoted by the contractor / bidder shall be written in figure as well as in words in English language clearly.

3.4 Each paper of tender documents should be signed by the contractors

The contractor / bidder should sign each page of the tender documents as well as correction and overwriting before submitting his tender.

3.5 Minimum requirement of plant / machinery / tools equipment for the purpose of execution of works under this contract

- | | | |
|----|---|---------------------------|
| 1. | Loaders / Shovel: ----- | 03-05 |
| 2. | Dump Trucks (10-12 wheelers) with high walls: | 16-20 |
| 3. | Excavator: ----- | 01 (as and when required) |

The minimum requirement is given just to provide a guideline to the contractor / bidder, so that they can understand the work assignment under this contract.

3.6 Variations in quantities

- The quantities of various item of work given in BOQ are tentative and may vary.
- If need arises, the Procuring Agency may ask the contractor / bidder to carry out the assigned work in adjacent district, but this shall be with mutual agreement between both parties. However, the payment shall be made as per the lowest rate of the work awarded for that district.
- SSWMB shall not entertain any claim, at any stage, by the contractor for non-availability of fore-casted volume of garbage for lifting and transportation from district to LFS.

3.7 Work during late hours or in emergencies

Contractors are hereby cautioned that they may be called for the work during holidays, in late hours and in emergency on directives of SSWMB.

3.8 Period of contract

One year from the issuance of work order, extendable for another month on the same rate without prejudice to the terms and conditions of the contract. However, if at any time, during the currency of contract, the continuation of the same becomes difficult or impossible due to factors beyond the control of SSWMB in that case the contract may be terminated, without any obligation, on 10 days prior notice from SSWMB to the contractor.

4.0 Procuring Agency's right to accept any tender and to reject any of all tenders

The Procuring Agency reserves the rights to accept or reject any tender / bid or to annual tendering process and reject all tenders at any time prior to award of contract without notice, thereby incurring no liability to the effected tenders or bidders. The Procuring Agency shall not be under any obligations to inform or justify the affected bidders of the ground for Procuring Agency's action.

4.1 The Procuring Agency reserves the right to fix maximum weight of garbage that can be loaded in and transported through a 10-12 wheeler dump truck based on the respective density of garbage. This may be required to discourage lifting and transport of Debris only. In that event any weight above and over the capacity worked out by the density of garbage as noted above shall not be considered for payment and shall be at contractor's own risk and cost.

4.2 The vehicle transporting solid waste from different points to landfill sites shall be completely covered by trampoline and not allowing any kind of spillage during the course of transporting.

Contractor's Signature

Executive Director (Operations-I) SSWMB

**Bill of Quantities
(FORM OF BID)
SSWMB-NIT-10.3/2017-18**

Estimated cost: Open rate Bid Security / Earnest money: 2% equivalent to quoted bid
Contract period: 12 months extendable for another month
Penalty per day: as per clause 1.14 above & Up to 2% of the contract price
Validity period: 90 days Tender fees: Rs. 3,000

**Subject: Transportation of Garbage from GTs & other areas of
District West, Karachi to Landfill Sites
(SSWMB-NIT-10.3/2017-18)**

S#	Description of work (Please read with Clause 1.8 above)	Unit	Qty	Rate per Ton (PKR)	Amount in PKR
01	Loading / Lifting its haulage transportation and unloading / disposal of all types of garbage / solid waste (excluding hazardous waste) and including but not limited to domestic / commercial garbage, rubbish, shrub, tree cutting of any condition and from (fry, semi dry or wet) as well as old debris mixed with garbage and inseparable from its etc from Garbage Transfer Stations (whether located within DMC West Jurisdiction or outside its limits but used by DMC West as formal or informal, temporary or permanent GTS or intermediate point for transfer of Garbage) to landfill sites (Jam Chakro and Gond Pass) including all charges, taxes and the cost of weightage of the Solid waste, LFS fee if any, complete service as directed by the authorized officers / committee according to work plan for the assignment.	Metric Ton (1000 Kg)	2000 - 2500 Tons per day + - 25%		

- Note: - Rate must be quoted both in figure and words otherwise liable to be rejected.
- Overwriting and correction, if any, must be initialed and stamped by the bidder
- I / we hereby quote Rate of Rs. _____ (in figure) Rupees
_____ (in words) per ton for above-mentioned work.
- I / we understand that it is not easy to quantify the weight of garbage / solid waste hence the quantity mentioned above is approximate and can vary + or - 25% or even more.
- I / we have read the standard bidding documents and amendment, if any and agree to abide by all of them.
- I / we have read the standard bidding documents and amendment, if any and agree to abide by all of them.
- I / we understand that this contract shall be governed under SINGLE STAGE – ONE ENVELOPE PROCEDURE as set out in Sindh Public Procurement Rules 2010 (amended 2017). All provisions of Sindh Public Procurement Rules 2010 (amended 2017), whether mentioned in this document or not, shall be applicable to the contract.

- I / We understand that SSWMB reserves the right to ask the contractor to lift, transport and dispose of Garbage (Solid Waste) from any adjacent area of the District in Karachi (not mentioned in the bidding document) to Landfill sites of Karachi.

Contractor Signature _____

Name of the Contractor / Company: _____

Name of the Contractor / Authorized person: _____

Address: _____

Phone: _____

Fax: _____

Email: _____

Date: _____

Seal of the Firm / Company

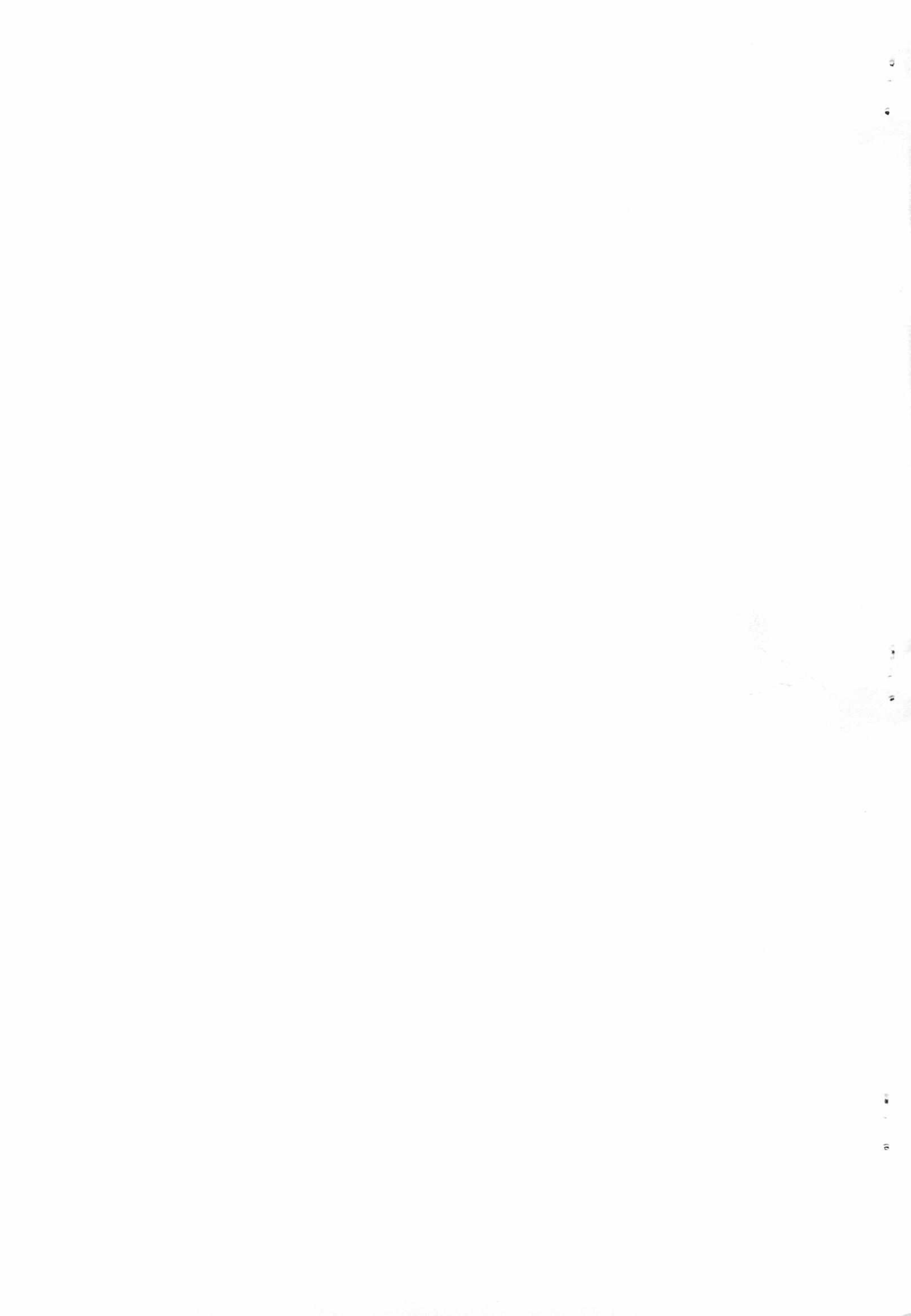



GOVERNMENT OF SINDH



Transportation of Garbage from GTSS & other areas of District Malir, Karachi to Landfill Sites

Tender Reference: SSWMB - NIT - 10.4 /2017-18

BIDDING DOCUMENTS

Procuring Agency:

Sindh Solid Waste Management Board

Bungalow # 13, Al-Hamra Housing Society, Shaheed e Millat Road, Karachi

Ph # 021-9933 3704-06, Fax # 021-9933 3707 Email Address: info@sswmb.gos.pk website: www.sswmb.gos.pk

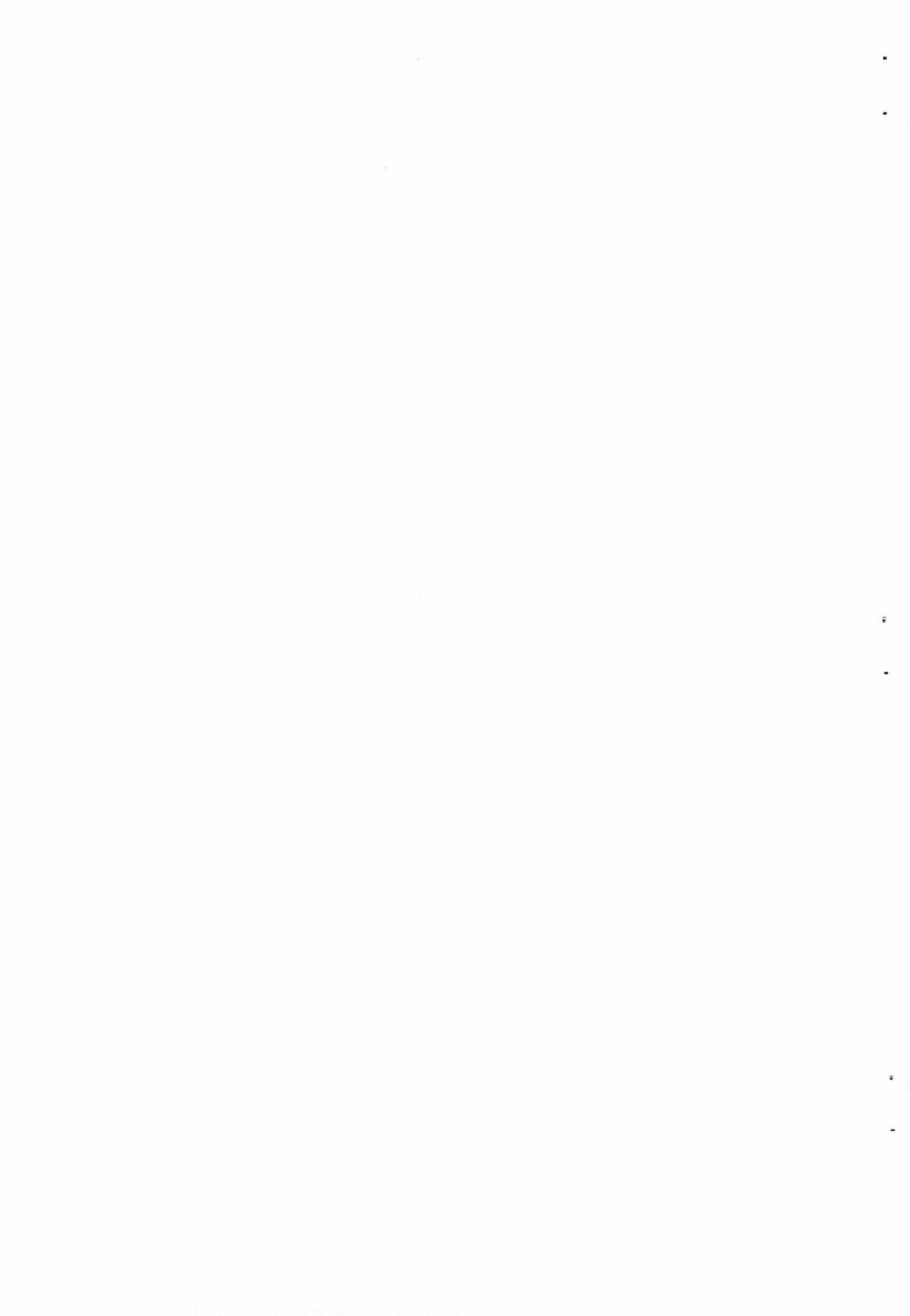

NOTICE INVITING TENDER
(SSWMB/NIT-9 & 10/ 2017-18)

Sindh Solid Waste Management Board (SSWMB) invites sealed bids from interested Contractors / Firms for carrying out the Works / Services mentioned below under *SINGLE STAGE – ONE ENVELOPE PROCEDURE*

TENDER REFERENCE NO.	NAME OF WORK	ESTIMATED COST	TENDER COST
NIT-9/2017-18			
NIT-9	Construction of Boundary Wall on different sites of GTS at Karachi. (Civil Works)	55.141 (Million)	Rs.3000/-
NIT-10/2017-18			
NIT-10.1	Transportation of Garbage from GTSs and other areas of District East, Karachi to Landfill Sites.	Open Rate	Rs.3000/- Each
NIT-10.2	Transportation of Garbage from GTSs and other areas of District South, Karachi to Landfill Sites.		
NIT-10.3	Transportation of Garbage from GTSs and other areas of District West, Karachi to Landfill Sites.		
NIT-10.4	Transportation of Garbage from GTSs and other areas of District Malir, Karachi to Landfill Sites.		

TENDER SCHEDULE

Sr. No.	Schedule	Date & Time	Venue
1.	Issuance of Bidding Documents	From 11-12-2017 to 26-12-2017 (Both days inclusive) during office hours.	Office of Assistant Director (Finance), SSWMB, Bungalow No.13, Al-Hamra Housing Society - Karachi.
2.	Submission of Bids	26-12-2017 at 1500 hours	Committee Room, Sindh Solid Waste Management Board, Bungalow No.13, Al-Hamra Housing Society - Karachi.
3.	Opening of Bids	26-12-2017 at 1530 hours	

- Interested companies can obtain Tender Documents including eligibility criteria upon payment of Tender Document Fee (non-refundable) through **PAY ORDER OR BANK DRAFT of Pak Rs.3,000/- (for each work)** in favor of **Sindh Solid Waste Management Board** as per schedule given above from the office of **Assistant Director (Finance)**, SSWMB during office hours. Alternatively the documents may also be downloaded from the website www.pprasindh.gov.pk or www.sswmb.gos.pk. The companies downloading the documents from the websites must submit Tender Document Fee in the shape of Pay Order or Demand Draft as mentioned above at the time of submission of the bid.
- Bid Security of amount equivalent to 2% of the total quoted bid amount must be attached with the bids.
- Proof of Registration with FBR (NTN / Sales Tax) and Sindh Revenue Board (SRB) is to be submitted with the bids.
- The Bids must be in sealed envelope and submitted **SEPARATE FOR EACH WORK / SERVICES**.
- The envelope must clearly state:
 - Name of the Work (e.g. Transportation of Garbage from GTSs and other areas of District East, Karachi to Landfill Sites and;**
 - Tender Reference Number as mentioned on the bid document (e.g. SSWMB/NIT.10.1/2017-18).**
- In case, the date of opening of bids is declared as a public holiday or non-working day due to force Majeure, the next official working day shall be deemed to be date for issuance, submission and opening of tenders. The time and venue shall remain unchanged.
- Sindh Solid Waste Management Board** shall not be responsible for any cost or expenses incurred by bidding firms and reserves the right to terminate the procurement process at any time subject to relevant provision of SPP Rules, 2010 (Amended 2017).

Deputy Director (Procurement)

Sindh Solid Waste Management Board

Bungalow # 13, Al-Hamra Housing Society, Shaheed e Millat Road, Karachi

Ph # 021-9933 3704-06, Fax # 021-9933 3707 Email Address: info@sswmb.gos.pk website: www.sswmb.gos.pk

**Transportation of Garbage from GTs and other areas of District Malir,
Karachi to Landfill Sites.
(SSWMB-NIT-10.4/2017-18)**

TENDER DOCUMENT	
SSWMB-NIT-10.3 (District Malir)	
Date and time of Submission:	26 th December 2017 latest by 1500 hours
Date and time of opening:	26 th December 2017 at 1530 hours
Place of opening:	Committee Room, Sindh Solid Waste Management Board, Bungalow No. 13, Al-Hamra Housing Society, Shaheed-e-Millat Road – Karachi
Date of issue:	
Name and address of Contractor:	_____
Contractor's Representative	
Name & Signature of Tender Issuing Officer:	
Bid Price:	
Offered Rate Rs. _____ (in words) Rupees _____ Per Ton	
[*Total Bid Amount Rs. _____	
(in words) Rupees _____]	
Bid Security 2% of the Total Quoted Bid amount only in the shape of Pay Order / Demand Draft No. _____ Bank / Branch _____ Dated _____	
Performance Security: 10% (2% at the time of agreement + 8% from running & final bill)	
Completion period: 12 months from date of award extendable for another month on the same rate and terms and conditions.	

CHECK LIST / COMPLIANCE TO MINIMUM ELIGIBILITY CRITERIA

(No bid shall be considered unless Minimum Eligibility Criteria is complied)

S. No.	Criteria / Requirement	Compliance Yes / No	Remarks
1.	Registration with FBR (NTN)		
2.	Registration with Sindh Revenue Board (SRB)		
3.	Valid Registration with Pakistan Engineering Council		
4.	Valid Registration with EPA		
5.	Relevant experience: The bidder should have at least 03 (Three) years experience in handling Solid Waste OR at least 03 (Three) years experience as Contractor of works involving transportation of material as a part of the construction or similar contract.		
6.	Proof of ability to carry out the work i.e. Detail of equipment machinery and transportation /owned/ leased hired by the bidder: i. Registration Books of Loaders / Dumpers owned by the bidders; OR ii. Agreement with Transport supplier along with Registration Number of machinery; OR iii. Any identical proof acceptable by the Procuring Committee.		
7.	List of similar assignments (Transportation of garbage or Construction Contracts) with cost, completed or under execution		
8.	List of litigation (if any) within last three (03) years, nature and status / out come		
9.	Affidavit / undertaking that firm has never been black listed		
10.	Each and Every page of bidding document signed		
11.	Proof of payment of Tender Fee		
12.	Bid Security attached (2% of the Total Quoted Bid amount): - Pay order / Draft / Bank Guarantee - Amount: Rs. -----/- (Rupees -----) - Bank & Branch ----- -----		

Contractor Signature

Name of the Contractor / Company: _____

Name of the Contractor / Authorized person _____

Address: _____

Phone: _____

Fax: _____

Email: _____

Date: _____

Seal of the Firm /

Instruction to bidders

Instruction to bidders and Conditions of Contract

General

1.1 Invitation for tenders

The Sindh Solid Waste Management Board (SSWMB) hereinafter referred as 'Procuring Agency' intends to invite sealed bids from the interested contractors / firms / companies having sufficient experience / resources for the following assignment / work:

Lifting of Garbage (Solid Waste), its Transportation and Disposal from Garbage Transfer Stations (Formal or Informal GTS, Temporary or Permanent) & other areas of DMC Malir Karachi to Landfill sites (Gondpass and Jam Chakro) as per detailed Scope of Work at 'Section 1.8' below

1.2 This contract shall be governed under SINGLE STAGE – ONE ENVELOPE PROCEDURE as set out in Sindh Public Procurement Rules 2010 (amended 2017).

1.3 All provisions of Sindh Public Procurement Rules 2010 (amended 2017), whether mentioned in this document or not, shall be applicable.

1.4 There is no bar on any contractor to participate in number of tenders i.e. A bidder can participate in tender for One, Two, or even all Four districts mentioned in Tender Notice. However, he will have to submit Separate Bid including Eligibility Criteria, Separate Tender Fee and Separate Bid Security for each District.

1.5 Manner and place, date and time for submission of bidding documents

Sealed bids along with Bid Security and proof of payment of tender fee should be submitted in the tender box of **Sindh Solid Waste Management Board (SSWMB), Bungalow No. 13, Al-Hamra Housing Society, Shaheed-e-Millat Road, Karachi not later than 1500 hours on 26th December 2017**. Bids can also be submitted through registered post or courier but SSWMB shall not be responsible for any delay in submission for whatsoever reasons. Bids submitted by fax, email or any other means except described above shall not be entertained.

1.6 Manner, place, date and time of opening of bids

The Bids shall be opened publically by the Procurement Committee in presence of bidders or their representatives in **Committee Room of Sindh Solid Waste Management Board (SSWMB), Bungalow No. 13, Al-Hamra Housing Society, Shaheed-e-Millat Road, Karachi on 26th December 2017 at 1530 hours**.

In case, the date of opening of bids is declared as a public holiday or non-working day due to force Majeure, the next official working day shall be deemed to be date for issuance, submission and opening of tenders. The time and venue shall remain unchanged.

1.7 Sub-letting of work

The contractor shall not sublet the whole work or any part thereof. The bidder shall be responsible for execution of the contract / providing the services as per BoQ. Subletting shall not be permissible under this contract and shall lead to disqualification. However, hiring of machinery, from open market, for carrying out this work, shall NOT be considered as subletting of the work.

1.8 Scope of work

The work under this contract comprises of Lifting transportation and disposal of all types of garbage / solid waste (excluding hazardous waste) and including but not limited to domestic / commercial garbage, rubbish, shrub, tree cutting of any condition and from (fry, semi dry or wet) as well as old debris mixed with garbage and inseparable from its etc from Garbage Transfer Stations (whether located within DMC Malir Jurisdiction or outside its limits but used by DMC Malir as formal or informal, temporary or permanent GTS or intermediate point for transfer of Garbage) to landfill sites (Jam Chakro and Gond Pass) including loading / unloading haulage / transportation and weightage from the designated weighbridges.

1.9 Eligibility Criteria (Please refer to Minimum Eligibility Criteria at page No. 4)

- a) Registration with FBR (NTN);
- b) Registration with Sindh Revenue Board (SRB);
- c) Valid Registration with Pakistan Engineering Council in Category-4;
- d) Valid Registration with EPA;
- e) Proof of payment of Tender Fee (Separate for Each District);
- f) Proof of payment of prescribed Bid Security (Separate for Each District);
- g) Relevant experience:
The bidder should have at least 03 (Three) years experience in handling Solid Waste

OR

at least 03 (Three) years experience as Contractor of works involving transportation of material (e.g. sand / building material) as a part of the contract.
- h) Proof of ability to carry out the work i.e. Detail of equipment machinery and transportation/owned/ leased hired by the bidder:
Arrangement of at least 03-05 heavy duty Loaders / Shovels and 16-20 (10-12 wheeler) Dump trucks with high walls or equivalent along with allied equipment.

Note:

- i. The proof can be either copies of registration papers of vehicles or an agreement with Transportation Vehicle Supplier showing Registration Number, type and capacity of vehicles, which shall be made available specifically for this district work.*
- ii. The same vehicle can't be quoted for work of another district i.e. same vehicle will not be counted for more than one district to undertake this work in the shape of arrangement;*

- iii. Any vehicle quoted by the contractor in any previous garbage lifting & transportation contract of SSWMB can't be re-quoted before expiry of that contract;
- iv. SSWMB reserves the right to carry out further checks to verify the ability of the bidder to accomplish the assignment.

- i) List of similar assignments with cost (mention number of projects) completed or under execution;
- j) List of litigation (if any) within last three (03) years, nature and status / outcome;
- k) Affidavit / Undertaking that firm has never been black listed;

1.10 Definition and interpretation

In this as document following words and expressions shall have the meaning hereby assigned to them, unless there is anything repugnant in the subject or context:

- i. "District" means an area declared as jurisdiction of particular "District Municipal Corporation" unless additional area is also included in the BIDDING DOCUMENT;
- ii. "Procuring Agency" means the SSWMB;
- iii. "Representative" means The Employee / committee notified or engaged by SSWMB for Monitoring this job;
- iv. "Scope of the work under this contract means" Lifting transportation and disposal of all types of garbage / solid waste (excluding hazardous waste) and including but not limited to domestic / commercial garbage, rubbish, shrub, tree cutting of any condition and from (dry, semi dry or wet) as well as old debris mixed with garbage and inseparable from it etc from Garbage Transfer Stations (whether located within DMC Malir Jurisdiction or outside its limits but used by DMC Malir as formal or informal, temporary or permanent GTS or intermediate point for transfer of Garbage) to landfill sites (Jam Chakro and Gond Pass) including loading / unloading haulage / transportation and weightage from the designated weighbridges.
- v. "SSWMB" means Sindh Solid Waste Management Board;
- vi. "Transportation of Garbage from any site in the district to Landfill Sites" means lifting, transportation and disposal of all types of garbage / solid waste and includes but not limited to domestic / commercial garbage, rubbish, shrub, tree cutting of any condition and from (dry, semi dry or wet) as well as debris mixed with garbage and inseparable from it etc, from any site in the concerned district to Landfill Sites (Gond Pass / Jam Chakro), including loading / unloading, haulage / transportation and weightage from the designated weighbridges;
- vii. Words "Bid Security and Earnest Money" are used synonymously and have same meaning;
- viii. Words "Performance Security and Security Deposit" are used synonymously and have same meaning;
- ix. Words "Contractor and Bidder" are used synonymously and mean the contractor or bidder, individual, firm or company who shows willingness to perform the 'work', on the rate quoted by him or his firm / company, on the terms and conditions set out in the NIT, this document as well as Sindh Public Procurement Rules 2010 (amended 2017);
- x. Words "Tender and Bid" are used synonymously and mean the Tender or Bid submitted by the individual Contractor, firm or Company;
- xi. Words "Garbage" and Solid Waste are used synonymously and mean all types of waste and includes but not limited to domestic / commercial garbage, rubbish, shrub, tree cutting of any condition and from (dry, semi dry or wet) as well as old debris mixed with garbage and inseparable from it etc.

1.11 Measurement of solid waste

All sort of Solid Waste as described in clause 1.8 & 1.10(iv) (Scope) above and also defined at 1.10.xi above shall be quantified / measured in tons (one metric ton / 1000 kg) for the respective load as per BOQ item of work. The solid waste shall be weighed on the independent weight bridge, designated / authorized or installed for the purpose by SSWMB. The cost of

weightage (weighbridge) of garbage shall be borne by the contractor. Any cost or fee for disposal of garbage at Landfill site shall be borne by the contractor.

1.12 Verification of weight of solid waste

Only weight slip of Solid Waste (Garbage) issued by designated weighbridge duly verified by the authorized officer / committee constituted for the purpose shall be considered for payment.

1.13 Minimum lifting capacity

The contractor shall be required to lift, transport and dispose of, whatever quantity of Solid Waste / Garbage is available, on the different GTS / collection points or accumulated Solid Waste at temporary collection points / temporary or permanent GTs / points of DMC Malir to designated landfill sites. Authorized officer (s) of SSWMB / DMC / Monitoring Committee constituted for the purpose shall designate the sites and intimate the contractor the schedule as well as the points from where to collect and lift the garbage and transport to Landfill site for disposal. The Contractor shall be bound to observe the minimum target quantity and schedule set by Authorized officer (s) of SSWMB / DMC / Monitoring Committee constituted for the purpose.

1.14 Failures to achieve minimum lifting target

The contractor shall be bound to arrange & manage lifting of routine garbage / solid waste as described above in clause 1.13 above for lifting / transportation of solid waste per day. In the event of failure to achieve the above target, a Penalty of Rs. 50,000/- per day for 1st three days of failure and Rs. 100,000/- of further period of failure shall be imposed subject to a maximum of 1% of the bid amount; thereafter the contract shall stand cancelled.

1.15 Rate analysis

The contractor shall provide, along with his tender / bid, analysis for his quoted rates for the items of work mentioned in BOQ including hiring charges of machinery, overhead cost of POL and other incidental charges,, if any. Failure to provide the rate analysis shall render the tender / bid non responsive & shall be summarily rejected.

1.16 Rates to be inclusive of all taxes

The tender rate shall be inclusive of all applicable taxes and incidental charges (e.g. weigh bridge charges, LFS charges etc.) in connection with the work.

2.1 Contactor's failure to start the work.

If the contractor fails to commence the work within 07 days after the work order issued to him, the Earnest Money (Bid Security) shall be forfeited and the work order shall be treated as cancelled.

2.2 Arrangement of water

The contractor should make his own arrangement of water, if required for the work execution as well as drinking and nothing will be paid / deducted for the same by Procuring Agency in the matter.

2.3 No alteration / addition in BOQ

No alteration or addition shall be made by the contractor in schedule of quantities. The rate must be filled in ink or typed out and mentioned in figure as well as words clearly and legibly in columns provided in schedule of quantities. Any correction must be initialed by the bidder. Any tender which does not comply with the terms and conditions shall be liable to be summarily rejected and shall not be considered.

2.4 Taxation

The rate and price in the tender by the contractor shall include all business tax, income tax, SRB tax and all other taxes that may be levied by the government according to the laws and regulation in being as of the date 28 days prior to the closing date of submission of tenders or levied from time to time during the contract. However, nothing in this document shall relieve the contractor from his responsibilities to pay any tax that may be levied by the government on the receivable amount / profit made to him in respect of the work during currency of the contract.

2.5 Tender validity

Tender shall remain valid for 90 days after the opening date of tender.

2.6 Security:

i. Bid Security (Earnest Money)

- The tender must be accompanied with **Bid Security (Earnest Money) equivalent to 2% of the contract price on the following form**
- *Bank draft / pay order or Bank Guarantee drawn of an approved scheduled bank in favour of SSWMB.*
- The Bid Security (Earnest Money) shall be calculated on the basis of Rate offered on average of 700 Tons Garbage per day for 365 days The Bid Security (Earnest Money) shall be returned to all bidders as soon as the contract is awarded to the Lowest Evaluated Bidder.

$$\text{Bid Security} = \text{PKR} = 700 \times 365 \times \text{Quoted Rate per Ton} \times 2\%$$

ii. Performance Security (Security Deposit)

- The total amount of **Performance Security (Security Deposit)** shall be 10% of the contract price approved by the Procuring Agency.
- The successful bidder shall deposit 2% Performance Security (Security Deposit) at the time of award of contract / agreement. The remaining 08% Performance Security (Security Deposit) shall be deducted from each running bill of the contractor.

2.7 Tender to be non responsive without prescribed Bid Security (Earnest Money)

Any tender which is not accompanied with required **Bid Security (Earnest Money)**, in the shape described above, shall be rejected by the Procuring Agency as non responsive.

2.8 Sufficiency of tender

Each contractor / bidder shall be deemed to have satisfied himself before tendering to the correctness and sufficiency of his tender as for as to cover his entire obligation.

2.9 Refund of Security deposit

The Performance Security (Security Deposit) of the successful bidder deposited at the time of award of the contract and also deducted during the contract period, shall be refunded after three month from the date of expiry of contract.

3.0 Conditional offers

All contractors / bidders are hereby cautioned that tenders with conditional offer or deviation from the conditions of contract or other requirements stipulated in their tender documents, shall be similarly rejected as non responsive and shall not be considered.

3.1 Damage to person and property

The contractors / bidders shall indemnify the Procuring Agency against all losses and claims in respect of;

- a) Death or injury to any persons due to accidents
- b) Loss or damage to any vehicle or property which might occur due to accident or in consequences of the execution of work and against all claims, proceeding, damages, costs, charges and expenses whatsoever in respect thereof or in relation thereto.

3.2 Canvassing in respect of tenders

Canvassing in connection with tenders is strictly prohibited and the tenders / bids submitted by contractor / bidder who resorts to canvassing will be liable to rejection.

3.3 Rate / Tenders amount to be quoted in figures as well as in words

The Rates quoted by the contractor / bidder shall be written in figure as well as in words in English language clearly.

3.4 Each paper of tender documents should be signed by the contractors

The contractor / bidder should sign each page of the tender documents as well as correction and overwriting before submitting his tender.

3.5 Minimum requirement of plant / machinery / tools equipment for the purpose of execution of works under this contract

1.	Loaders / Shovel: -----	02-03
2.	Dump Trucks (10-12 wheelers) with high walls:	08-10
3.	Excavator: -----	01 (as and when required)

The minimum requirement is given just to provide a guideline to the contractor / bidder, so that they can understand the work assignment under this contract.

3.6 Variations in quantities

- The quantities of various item of work given in BOQ are tentative and may vary.
- If need arises, the Procuring Agency may ask the contractor / bidder to carry out the assigned work in adjacent district, but this shall be with mutual agreement between both parties. However, the payment shall be made as per the lowest rate of the work awarded for that district.
- SSWMB shall not entertain any claim, at any stage, by the contractor for non-availability of fore-casted volume of garbage for lifting and transportation from district to LFS.

3.7 Work during late hours or in emergencies

Contractors are hereby cautioned that they may be called for the work during holidays, in late hours and in emergency on directives of SSWMB.

3.8 Period of contract

One year from the issuance of work order, extendable for another month on the same rate without prejudice to the terms and conditions of the contract. However, if at any time, during the currency of contract, the continuation of the same becomes difficult or impossible due to factors beyond the control of SSWMB in that case the contract may be terminated, without any obligation, on 10 days prior notice from SSWMB to the contractor.

4.0 Procuring Agency's right to accept any tender and to reject any of all tenders

The Procuring Agency reserves the rights to accept or reject any tender / bid or to annual tendering process and reject all tenders at any time prior to award of contract without notice, thereby incurring no liability to the effected tenders or bidders. The Procuring Agency shall not be under any obligations to inform or justify the affected bidders of the ground for Procuring Agency's action.

4.1 The Procuring Agency reserves the right to fix maximum weight of garbage that can be loaded in and transported through a 10-12 wheeler dump truck based on the respective density of garbage. This may be required to discourage lifting and transport of Debris only. In that event any weight above and over the capacity worked out by the density of garbage as noted above shall not be considered for payment and shall be at contractor's own risk and cost.

4.2 The vehicle transporting solid waste from different points to landfill sites shall be completely covered by trampoline and not allowing any kind of spillage during the course of transporting.

Contractor's Signature

Executive Director (Operations-I) SSWMB

**Bill of Quantities
(FORM OF BID)
SSWMB-NIT-10.4/2017-18**

Estimated cost: Open rate Bid Security / Earnest money: 2% equivalent to quoted bid
Contract period: 12 months extendable for another month
Penalty per day: as per clause 1.14 above & Up to 2% of the contract price
Validity period: 90 days Tender fees: Rs. 3,000

**Subject: Transportation of Garbage from GTs & other areas of
District Malir, Karachi to Landfill Sites
(SSWMB-NIT-10.4/2017-18)**

S#	Description of work (Please read with Clause 1.8 above)	Unit	Qty	Rate per Ton (PKR)	Amount in PKR
01	Loading / Lifting its haulage transportation and unloading / disposal of all types of garbage / solid waste (excluding hazardous waste) and including but not limited to domestic / commercial garbage, rubbish, shrub, tree cutting of any condition and from (fry, semi dry or wet) as well as old debris mixed with garbage and inseparable from its etc from Garbage Transfer Stations (whether located within DMC Malir Jurisdiction or outside its limits but used by DMC Malir as formal or informal, temporary or permanent GTS or intermediate point for transfer of Garbage) to landfill sites (Jam Chakro and Gond Pass) including all charges, taxes and the cost of weightage of the Solid waste, LFS fee if any, complete service as directed by the authorized officers / committee according to work plan for the assignment.	Metric Ton (1000 Kg)	500 - 700 Tons per day + - 25%		

- Note: - Rate must be quoted both in figure and words otherwise liable to be rejected.
- Overwriting and correction, if any, must be initialed and stamped by the bidder
- I / we hereby quote Rate of Rs. _____ (in figure) Rupees
_____ (in words) per ton for above-mentioned work.
- I / we understand that it is not easy to quantify the weight of garbage / solid waste hence the quantity mentioned above is approximate and can vary + or - 25% or even more.
- I / we have read the standard bidding documents and amendment, if any and agree to abide by all of them.
- I / we have read the standard bidding documents and amendment, if any and agree to abide by all of them.
- I / we understand that this contract shall be governed under SINGLE STAGE - ONE ENVELOPE PROCEDURE as set out in Sindh Public Procurement Rules 2010 (amended 2017). All provisions of Sindh Public Procurement Rules 2010 (amended 2017), whether mentioned in this document or not, shall be applicable to the contract.

- I / We understand that SSWMB reserves the right to ask the contractor to lift, transport and dispose of Garbage (Solid Waste) from any adjacent area of the District in Karachi (not mentioned in the bidding document) to Landfill sites of Karachi.

Contractor Signature _____

Name of the Contractor / Company: _____

Name of the Contractor / Authorized person: _____

Address: _____

Phone: _____

Fax: _____

Email: _____

Date: _____

Seal of the Firm / Company



*** ANNUAL PROCUREMENT PLAN (2017-2018)**
(WORKS, GOODS & SERVICES)

Name of Procuring Agency : **SINDH SOLID WASTE MANAGEMENT BOARD, KARACHI**

Date: **DECEMBER - 2017**

1	2	3	4	5	6	7	8	9	10	11	12	13
S.No	Description of Procurement	Quantity (Where applicable)	Estimated Unit Cost (Where applicable)	Estimated Total Cost (Rupees)	Funds allocated	Source of Funds (ADP/Non-ADP)	Proposed Procurement Method **	Timing of Procurements				Remarks
								1st Qtr	2nd Qtr	3rd Qtr	4th Qtr	
1	Arrangement for Lifting , Transportation and Burial of Offals on the Occasion of Eid-ul-Azha, DMC South Areas	-	-	25.0 (Million)	25.0 (Million)	Non-ADP	Open Competitive Bidding	Aug-17				
2	Arrangement for Lifting , Transportation and Burial of Offals on the Occasion of Eid-ul-Azha, DMC East Areas	-	-	25.0 (Million)	25.0 (Million)	Non-ADP	Open Competitive Bidding	Aug-17				
3	Procurement of Computers, Laptops, Printers , Photocopier, Fax , Scanners, Smart TV	-	-	5.0 (Million)	5.0 (Million)	Non-ADP	Open Competitive Bidding	Aug-17				
4	Construction of Boundary Wall around SSWMB Landfill Site at Deh Jam Chakro (Near Surjani Town), and Deh Gond Pass (Hub River Road) Karachi (Civil Works)	-	49.300 (Million)	98.600 (Million)	100.0 (Million)	ADP	Open Competitive Bidding		Oct-17			
5	Operation and Maintenance of SSWMB Landfill Site at Deh Jam Chakro (Near Surjani Town), and Deh Gond Pass (Hub River Road) Karachi	-	-	200 (Million)	200 (Million)	Non-ADP	Open Competitive Bidding		Oct-17			
6	Supply, erection, testing and Commissioning of 120 MT Pit Mounted Type Electronic Road Weighbridge along with customizable software at six different sites of GTS in Karachi.	6	8.0 (Million)	48.0 (Million)	100 (Million)	ADP	Open Competitive Bidding		Oct-17			
7	Supply, Erection, Testing and Commissioning of 120 MT Pit Mounted Type Electronic Road Weighbridge along with customizable software at two different sites of Landfill Site in Karachi.	2	8.0 (Million)	16.0 (Million)	20.0 (Million)	ADP	Open Competitive Bidding		Oct-17			
8	Supply, Erection, Testing and Commissioning of 120 MT Pitless / Portable / Moveable Electronic Weighbridge along with customizable software at different designated locations in Karachi.	2	8.0 (Million)	48.0 (Million)	100 (Million)	Non-ADP	Open Competitive Bidding		Oct-17			
9	Customization of Weigh Bridge Software and its Operation / Maintenance including remote monitoring as well as automatic / systematic reporting of weigh bridge system at SSWMB Landfill Site & GTS in Karachi.	-	-	200 (Million)	200 (Million)	Non-ADP	Open Competitive Bidding		Oct-17			



*** ANNUAL PROCUREMENT PLAN (2017-2018)**
(WORKS, GOODS & SERVICES)

Name of Procuring Agency : **SINDH SOLID WASTE MANAGEMENT BOARD, KARACHI**

Date: DECEMBER - 2017

1	2	3	4	5	6	7	8	9	10	11	12	13
S.No	Description of Procurement	Quantity (Where applicable)	Estimated Unit Cost (Where applicable)	Estimated Total Cost (Rupees)	Funds allocated	Source of Funds (ADP/Non-ADP)	Proposed Procurement Method **	Timing of Procurements				Remarks
								1st Qtr	2nd Qtr	3rd Qtr	4th Qtr	
10	Construction of Boundary Wall around different sites of GTS at Karachi (Civil Works)	-	55.141 (Million)	55.141 (Million)	60.00 (Million)	ADP	Open Competitive Bidding		Dec-17			
11	Transportation of Garbage from Garbage Transfer Stations (GTS) & Other areas of District East, to Landfill Sites	-	-	200,000,000	200,000,000	Non-ADP			Dec-17			
12	Transportation of Garbage from Garbage Transfer Stations (GTS) & Other areas of District South, to Landfill Sites	-	-	220,000,000	220,000,000	Non-ADP			Dec-17			
13	Transportation of Garbage from Garbage Transfer Stations (GTS) & Other areas of District West, to Landfill Sites	-	-	300,000,000	300,000,000	Non-ADP			Dec-17			
14	Transportation of Garbage from Garbage Transfer Stations (GTS) & Other areas of District Malir, to Landfill Sites	-	-	100,000,000	100,000,000	Non-ADP			Dec-17			
15	Providing of Security Gaurds	-	-	800,000	1,625,000	Non-ADP	Open Competitive Bidding		Dec-17			
16	Purchase of Office Stationary & Computer Stationary	-	-	19,70,000	19,70,000	Non-ADP	Open Competitive Bidding		Dec-17			
17	Printing and Publication	-	-	975,000	975,000	Non-ADP	Open Competitive Bidding		Dec-17			
18	Purchase of Office Furniture	-	-	12,200,000	12,200,000	Non-ADP	Open Competitive Bidding		Dec-17			
19	PROCUREMENT OF CONSULTANCY SERVICES FOR SINDH SOLID WASTE MANAGEMENT BOARD (SSWMB)								Dec-17			
	A. Hiring of Individual Legal Consultants for SSWMB.		-	-					Dec-17			
	B. Hiring of Consultants for Feasibility Studies of Waste to Energy.		-	-					Dec-17			



*** ANNUAL PROCUREMENT PLAN (2017-2018)**
(WORKS, GOODS & SERVICES)

Name of Procuring Agency : **SINDH SOLID WASTE MANAGEMENT BOARD, KARACHI**

Date: **DECEMBER - 2017**

1	2	3	4	5	6	7	8	9	10	11	12	13
S.No	Description of Procurement	Quantity (Where applicable)	Estimated Unit Cost (Where applicable)	Estimated Total Cost (Rupees)	Funds allocated	Source of Funds (ADP/Non-ADP)	Proposed Procurement Method **	Timing of Procurements				Remarks
								1st Qtr	2nd Qtr	3rd Qtr	4th Qtr	
	C. Monitoring, Evaluation & Supervision of 'Front End Collection, Transportation & Disposal of Municipal Solid Waste Contract of DMC - South, Karachi	-	-						Dec-17			
	D. Monitoring, Evaluation & Supervision of 'Front End Collection, Transportation & Disposal of Municipal Solid Waste Contract of DMC - East, Karachi	-	-	50,000,000	32,000,000	Non-ADP	Open Competitive Bidding		Dec-17			
	E. Monitoring, Evaluation & Supervision of 'Front End Collection, Transportation & Disposal of Municipal Solid Waste Contract of DMC - West, Karachi	-	-						Dec-17			
	F. Monitoring, Evaluation & Supervision of 'Front End Collection, Transportation & Disposal of Municipal Solid Waste Contract of DMC - Malir, Karachi	-	-						Dec-17			
	G. Hiring of Consulting Firm for Techno Economic Feasibility Study for Establishment of Integrated Solid Waste Management in Hyderabad and Qasimabad	-	-						Dec-17			
	H. Hiring of Consultants for Integrated Solid Waste Management Project Nawabshah - Phase-I.	-	-			ADP	Open Competitive Bidding		Dec-17			
	I. Hiring of Consultants for Detail Engineering Design & Supervision of LFS of Hyderabad.	-	-			ADP	Open Competitive Bidding		Dec-17			
	J. Detailed Engineering Design and Construction Supervision of Garbage Transfer Stations & Misc. Works	-	-			ADP	Open Competitive Bidding		Dec-17			
	K. Detailed Engineering Design and Construction Supervision of Landfill Site of SSWMB	-	-			ADP	Open Competitive Bidding		Dec-17			
20	Purchase of Transport	-	-	5,200,000	5,200,000	Non-ADP	From Authorised Dealer				Jan-18	
21	Establishment of Six GTS with Material Recovery (MR) and Refuse Derived Fuel (RDF) facility in Karachi. (On going schemes)	-	-	1660.796 (Million)	455.0 (Million)	ADP	Open Competitive Bidding				Mar-18	



*** ANNUAL PROCUREMENT PLAN (2017-2018)**
(WORKS, GOODS & SERVICES)

Name of Procuring Agency : **SINDH SOLID WASTE MANAGEMENT BOARD, KARACHI**

Date: DECEMBER - 2017

1	2	3	4	5	6	7	8	9	10	11	12	13
S.No	Description of Procurement	Quantity (Where applicable)	Estimated Unit Cost (Where applicable)	Estimated Total Cost (Rupees)	Funds allocated	Source of Funds (ADP/Non-ADP)	Proposed Procurement Method **	Timing of Procurements				Remarks
								1st Qtr	2nd Qtr	3rd Qtr	4th Qtr	
22	Development of Sanitary Engineering existing two Landfill Sites & their Scientific Improvement (ADP 2016-17)	-	-	1187.247 (Million)	275.000 (Million)	ADP	Open Competitive Bidding			Mar-18		
23	Integrated Solid Waste Management Project Nawabshah Municipal Committee, Shaheed Benazirabad District (Phase - I) (On going schemes)	-	-	438.326 (Million)	284.326 (Million)	ADP	Open Competitive Bidding				Apr-18	
24	Establishment of Sanitary Landfill Site, Hyderabad. (ADP 2016-17)	-	-	461.909 (Million)	107.500 (Million)	ADP	Open Competitive Bidding				Apr-18	
25	Intergrated Municipal Solid Waste Management Project Nawabshah Municipal Committee (Phase-II) Landfill Site + Material Recover Facility. (ADP 2016-17)	-	-	549.395 (Million)	100.000 (Million)	ADP	Open Competitive Bidding				Apr-18	

* The Annual Procurement Plan is prepared on the assumption that total allocation budget will be released.

** Procurement method means Open Competitive Bidding / Petty Purchase / Quotatons / Direct Contracting / Negotiating Tender