

## SCHEDULE "B"

Name of work:- Provision and Installation of hand pump at Kohistan area in District Jamshoro Taluka Thano Bola Khan Union Council Mole and Thano Bola Khan (Deep Hand pump)

- |                        |  |           |               |         |                     |
|------------------------|--|-----------|---------------|---------|---------------------|
| 1.                     | Boring of Tube Well in water bearing soil from ground level upto 100ft depth i/c sinking and with drawing and casing pipes (PHSNo. 1P/36).   | 8500 Rft  | @ Rs.414/=    | Per Rft | Rs.3,519,000/- ✓    |
| 2.                     | Boring of Tube Well in water bearing soil from depth 101' to 200' below ground level i/c sinking and with drawing and casing pipes (PHSNo. 2P/42).   | 6800 Rft  | @ Rs.516.00   | Per Rft | Rs.3,508,800/- ✓    |
| 3.                     | Supplying and Installing PVC Blind pipe "C" Class approved designed quality and make i/c necessary sockets etc complete (PHSNo. 11P/14 & PHSMINo. 16P/111).  | 8500 Rft  | @ Rs.212.10   | Per Rft | Rs.1,802,850/- ✓    |
| 4.                     | Supplying and Installing PVC Strainer Pipe "B" Class of approved design quality including necessary sockets etc complete. (PHSNo. 9b P/43).  | 6800 Rft  | @ Rs.242.95   | Per Rft | Rs.-16,52,060/- ✓   |
| 5.                     | Shrouding with Graded Bajri (3/8" to 1/8" or 9 to 3mm) in between bore and blind pipe for the following diameter or strainer (PHSINO. 13P/35).   | 7650 Rft  | @ Rs.49/=     | Per Rft | Rs:-374,850/- ✓     |
| 6.                     | Construction of CC Platform inside 4' x 4' with 1/2" Thick Wall and CC drain in length 10' (Based on scheduled rate)   | 85-Nos    | @ Rs.6691/=   | Each=   | Rs:-568,735/-       |
| <b>Total Rupees: A</b> |  |           |               |         | <b>114,26,295/-</b> |
| 7.                     | Supplying installing Rising with one end socket factor Standar DS 3505 Pipe material UPVC class 'E' pipe pressure 15 Bars wall thickness 4.7 mm dia 63 mm (Rate approved)  | 12750 Rft | @ Rs.- 68/-   | Per Rft | Rs:- 867000/- ✓     |
| 8.                     | Supplying, Installing and Testing Deep hand pump pipe machine suitable for Kohistan area superior quality make as per site requirement i.e including all required accessories. i/c Labor Charges for leveling the hand pump. | 85-Nos    | @ Rs.- 2450/- | Each=   | Rs:- 208250/-       |

### TERMS AND CONDITIONS

1. Arbitration clause stands deleted from the agreement.
2. Any typographical errors in the schedule "B" are subject to correction with the reference to the schedule of rates General item 2012 in force -10-2012 as approved by the standing rates Committee Sindh, Karachi.
3. Water shall be arranged by the contractor at site of work without any extra payment.
4. No premium shall be paid on non-Schedule items.
5. No Cartage or any item of material either supplied by the Department or arranged by the Contractor shall be paid.
6. Contractor has to bring sample of the material and handed to the Engineer in charged free of cost.
7. All buildings debris & surplus stuff not req. for use construction shall be removed from the site and suitable disposed off by the contractor for which no extra cartages shall be paid.
8. This work will be carried out as per PWD Specifications.

CIVIL ENGINEER (PDMA)

DIRECTOR FINANCE (PDMA)

Total Cost - Rs. 14,375,775/-  
Say to Rs. 14.375-Million.

DEEP HAND PUMP  
KOHISTAN AREA OF THATTA DISTRICT

pl<sub>1</sub> 5m  
pl<sub>2</sub> 4 1/2"  
pl<sub>3</sub> 5m  
pl<sub>4</sub> 6"

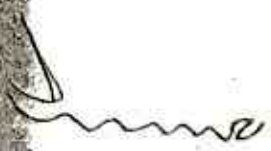
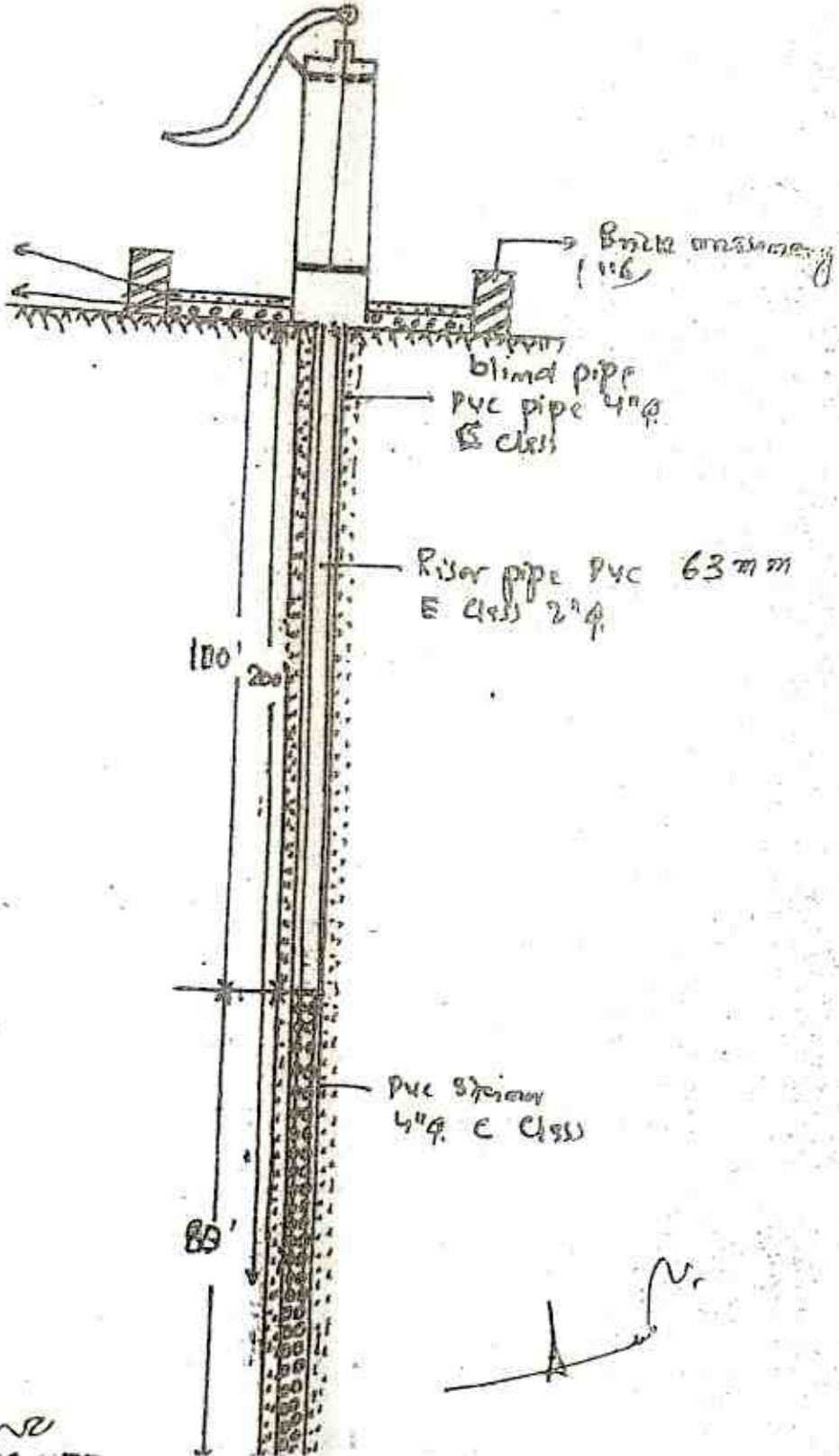

PLAN AND SECTION OF PLATE FORM FOR HAND PUMP

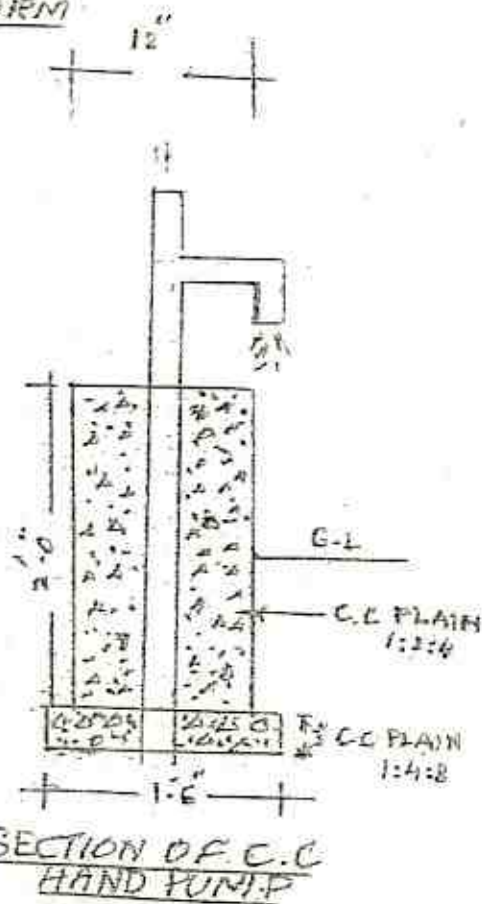
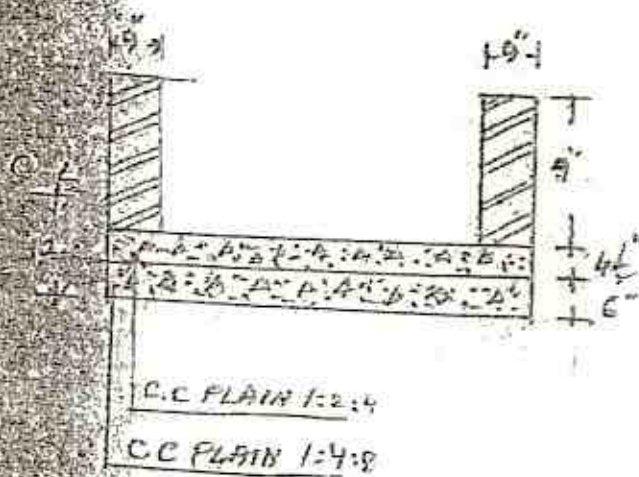

SECTION OF PLAT FORM.

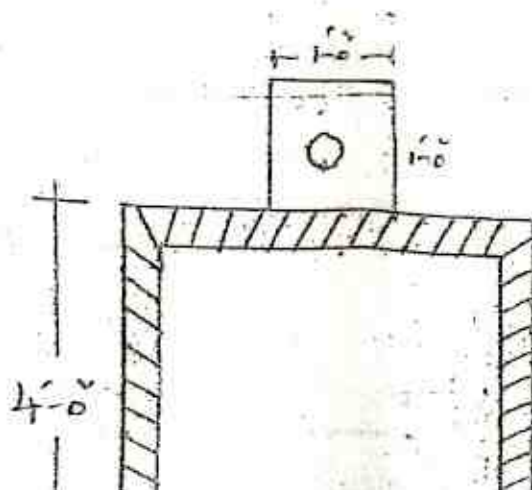

*Signature*

489989 RS 43100/ 266

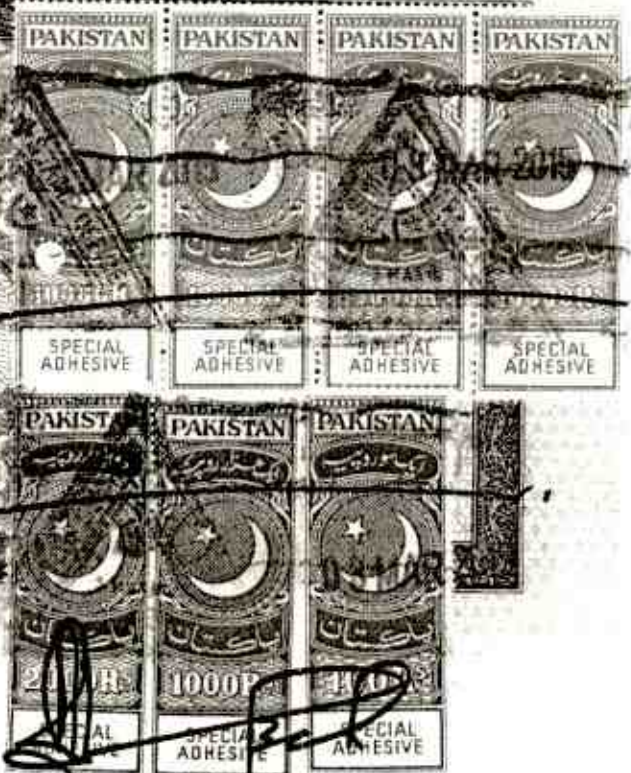

SIKANDAR IMRAN STAMP VENDOR

License No. 66, Seat No. 10, City Court

29732

16 FEB 2015

M/S NEVAT MAL

Signature of SIKANDAR IMRAN

Signature of M/S NEVAT MAL

Signature of SIKANDAR IMRAN

Signature of M/S NEVAT MAL

OFFICE SUPERINTENDENT  
City Court  
Karachi

03 MAR 2015

FORM OF CONTRACT AGREEMENT  
SUM OF RS.14.375-MILLION

THIS CONTRACT AGREEMENT (hereinafter called the Agreement) made on the 23rd day of February, 2015 between Provincial Disaster Management Authority Rehabilitation Department Governments of Sindh Karachi

And

M/S Nevat Mal Government Contractor, Office at Top Ands Store, Bolani Muhalla jamote Bara, Ibrahim Hyderi Karachi (hereinafter called the Contractor) of the other part

WHEREAS, the Provincial Disaster Management Authority, lying its office in Bungalow No. 40, Street No.24 Khayaban-e- Mujahid DHA Phase V Karachi, is desirous certain work" Viz PROVISION AND INSTALLATION OF DEEP HAND PUMPS IN KOHISTAN AREA IN DISTRICT JAMSHORO TALUKA THANA BULA KHAN UNION COUNCIL MOLE AND T.B.KHAN (DEEP HAND PUMPS 85-Nos) Should be executed & completed by the contractor and has accepted a bid, by the contractor for the execution and completion of the work and the remedying of any defects therein.

NOW this Agreement witnesses as follows:

1. In this Agreement words and expressions shall have the same meanings as are respectively assigned to them in the Conditions of Contract hereinafter referred to.

M/S NEVAT MAL  
Govt. Contractor  
Proprietor



Handwritten signature of M/S Nevat Mal.

2. The following documents after incorporating addenda, (if any) except those parts relating to Instructions to Bidders, shall be deemed to form and be read and construed as an integrated part of this Agreement, viz:

- (a) The Letter of Acceptance; (Annex-I)
- (b) The completed Form of Bid along with Schedules to Bid; (Annex-II)
- (c) Conditions of Contract & Contract Data ;( Annex-III)
- (d) The priced Schedule of Prices/Bill of quantities (BOQ); (Annex-IV)
- (e) The Specifications; (Annex-V) and
- (f) The Drawings (Annex-VI)
- (g) General Condition
  - (i) In case of any variation in provisions of Schedule-B - as per accepted tender and technically sanction detailed working estimate, the execution of work shall be regulated in accordance with the provisions as per technically sanctioned working estimate.
  - (ii) No Premium shall be allowed on Non-Schedule Items.
  - (iii) The payment is not made to the firm, if the water does not comes after boring.
  - (iv) No separate payment for carriage of material will be allowed.
  - (v) All Material required in connection of the subjected work shall be procured and brought at site by the Contractor at his own cost.
  - (vi) No Payment of extra items shall be made unless written order is given by the Undersigned for execution of the extra items and approved by the competent authority.
  - (vii) Income tax shall be deducted from the bills on the above values of work done and paid for as per Latest order of competent authority in this regard.
  - (viii) The Sales tax invoice on taxable items should be provided to this office for record.
  - (ix) Sweet & palatable water only shall have to be used in construction work which is to be arranged by the contractor.
  - (x) The Arbitration clause from the agreement stands deleted.
  - (xi) The work must be carried out as per PWD/PHE specifications.
  - (xii) The successful bidder shall furnish 5% performance security of contract value, in the shape of bank guarantee to procuring agency within the period of (14) Fourteen days of the receipt of letter of acceptance of work order.



**M/S NEVAT MAL**  
Govt. Contractor  
Proprietor

3. In consideration of the payments to be made by the Procuring Agency to the Contractor as hereinafter mentioned, the Contractor hereby covenants with the Procuring Agency to execute and complete the Works and remedy defects therein in conformity and in all respects within the provisions of the Contract.

4. The Procuring Agency hereby covenants to pay the Contractor, in consideration of the execution and completion of the Works as per provisions of the Contract, the Contract Price or such other sum as may become payable

under the provisions of the Contract at the times and in the manner prescribed by the Contract.

5. Now withstanding anything contained to the contrary or conflict with the provision of this agreement in any of the documents mentioned in clause 1, above the provision of this agreement shall prevail and the documents mentioned above, shall be deemed to have been amended to the extent of inconsistency found therein, by the provision of this agreement, in case of in-consistency between any of the document referred to herein, the later documents shall prevail and the tender documents shall be constructed to have been amended to that extend.

6. this contract shall not be transferable or assignable in whole or part of any of parties hereto, provided that the owner may assign his rights and obligations in whole or in part or any other company which shall be entirely owned Company belonging to the same group of the companies as the owner, in such as event touch other company shall be either to act to as owner under this contract.

IN WITNESS WHEREOF the parties hereto have caused this Contract Agreement to be executed on the day, month and year first before written in accordance with their respective Laws.



NEVAT MAL

GOVERNMENT CONTRACTOR



NAZAR MUHAMMAD BOZDAR  
DIRECTOR (F&A)  
PDMA, SINDH



Signed, Sealed and Delivered in the presence of:

Witness:

Signature



Name

Dilip Kumar

Title:

\_\_\_\_\_

CNIC:

42301-197203-1

Witness:

Signature



Name

Ajay Kumar Senani

Title:

Assistant Director

CNIC:

42201-7942551-5



OFFICE OF THE PROVINCIAL DISASTER MANAGEMENT AUTHORITY KARACHI

(6)

Tender Form issued to M/S: NEVAT MAL Govt. Contractor

Charge to Rs:-3000/= Vide D.R No: 03447053 Dated the:- 08-01- 2015

  
DIRECTOR FINANCE (PDMA)  
GOVERNMENT OF SINDH KARACHI

NAME OF WORK:-

PROVISION AND INSTALATION OF HAND DEEP PUMP AT KOHISTAN AREAS IN DISTRICT THATTA TALUKA THATTA UNION COUNCIL JUNGSHAHI, CHUTO CHAND, ONGAR (DEEP HAND PUMP 86-NOS & SHALLOW HAND PUMP 23-NOS)

I/We hereby tender for execution of the works of Government of Sindh herein before/after referred to as Government of the work specification in the written memorandum with time specification in each memorandum at:-

  
Civil Work  
**M/S NEVAT MAL**  
Govt. Contractor  
Proprietor

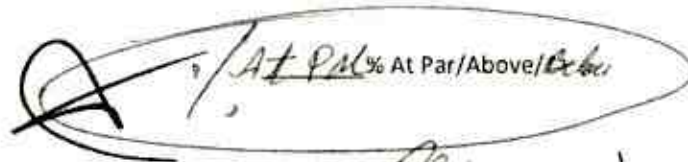
  
At 9% At Par/Above/Below

(CONTRACTOR SIGNATURE)

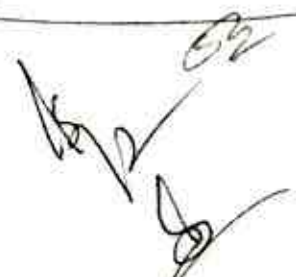

DIRECTOR FINANCE (PDMA)  
GOVERNMENT OF SINDH KARACHI

The estimate carried out & according to all respect with the specification design/drawing & instruction in writing referred to rule-I here of the clause-12 of the annexed condition of the contract & agreement that when material for the work are provided by the Govt: such material & rate to paid for then shall be as provided in Schedule 'B' here to:-

GENERAL DESCRIPTION

i.	Estimated Cost	Rs:-17.013-Million
ii.	Earnest Money 2%	Rs:-0.340-Million
iii.	S/Deposit in/c: E/Money 10%	Rs:-1.701-Million
iv.	Income Tax will be deducted 7%	Rs:-1.190-Million
v.	Time of Completion of Work:-	Rs:-03-Months

We have offered the above rates after taking into consideration all the terms & conditions as per B-I printed tender & form so as to completed the agreement, in case of Failure the Department will be at liberty to take action me /us.

BIDDING DACUMENTS/BOQ

Attached herewith

Call Deposit/Pay order bearing No: 0000233284 Dated: 13/01/2015  
Amounting to Rs:- 381500/- Bank The Bank of Punjab Branch Karachi  
Is enclosed herewith as desired on account of Security Deposit

**M/S NEVAT MAL**  
Govt. Contractor  
  
(CONTRACTOR SIGNATURE)

## BILL OF QUANTITIES

Name of work:- Provision and Installation of hand pump at Kohistan area in District Jamshoro Taluka u/C Jung Shahi - Chatto Chand and Onagar ( Deep Hand Pump 86 Nos and Shallow Pump 23-Nos)

1.	Boring of Tube Well in water bearing soil from ground level upto 100ft depth i/c sinking and with drawing and casing pipes (PHSNo.1P/36).			
	8600 Rft	@ Rs.414/=	Per Rft	Rs 35,60,400/-
2.	Boring of Tube Well in water bearing soil from depth 101' to 200' below ground level i/c sinking and with drawing and casing pipes (PHSNo. 2P/42)			
	6880 Rft	@ Rs.516/=	Per Rft	Rs.35,50,080 /-
3.	Supplying and Installing PVC Blind pipe "C" Class approved designed quality and make i/c necessary sockets etc complete (PHSNo.11P/14 & PHSMNo.16P/111).			
	8600Rft	@ Rs.212 10	Per Rft	Rs.18,24,060/-
4.	Supplying and Installing PVC Strainer Pipe "B" Class of approved design quality including necessary sockets etc complete.(PHSNo.9b P/43).			
	6880Rft	@ Rs.242,95	Per Rft	Rs.16,71,496 /-
5.	Shrouding with Graded Bajri (3/8" to 1/8" or 9 to 3mm) in between bore and blind pipe for the following diameter or strainer (PHSNo. 13P/35).			
	7740Rft	@ Rs.49/=	Per Rft	Rs.379,260/-
6.	Construction of CC Platform inside 4' x 4' with 1/2" Thick Wall and CC drain in length 10' (Based on scheduled rate).			
	86-Nos	@ Rs:-6691/=	Each	Rs.575,426/-
			Total Rupees:-	11560722/-
7.	Supplying installing Rising with one end socket factor Standard DS 3505 Pipe material UPVC class 'E' pipe pressure 15 Bars wall thickness 4.7 mm dia 63 mm			
	12900Rft	@ Rs. 681/2	Per Rft	Rs. 877200/-
8.	Supplying, Installing and Testing Deep hand pump pipe machine suitable for Kohistan area superior quality make as per site requirement i.e including all required accessories i.e Labor Charges for levering the hand pump.			
	86-Nos	@ Rs.-24500/-	Each	Rs:-2107000/-

### TERMS AND CONDITIONS

1. Arbitration clause stands deleted from the agreement.
2. Any typographical errors in the schedule "B" are subject to correction with the reference to the schedule of rates General item 2012 in force -10-2012 as approved by the standing rates Committee Sindh, Karachi.
3. Water shall be arranged by the contractor at site of work without any extra payment.
4. No premium shall be paid on non-Schedule items.
5. No Cartage or any item of material either supplied by the Department or arranged by the Contractor shall be paid.
6. Contractor has to bring sample of the material and handed to the Engineer in charged free of cost.
7. All buildings debris& surplus stuff not req. for use construction shall be removed from the site and suitable disposed off by the contractor for which no extra cartages shall be paid.
8. This work will be carried out as per PWD Specifications.

CIVIL ENGINEER (PDMA)

DIRECTOR FINANCE (PDMA)

GENERAL ABSTRACT

Total Schedule Items Rs. 1,31,08,855/-

Total N.S. items Rs. 31,40,600/-

Total Cost Rs. 1,62,49,455/-

Say Rs. 16.249.455/-



**SCHEDULE "B"**

**Name of Work:** Provision and Installation of Hand Pump at Kohistan area in District & Taluka Thatta U/C Jungshahi, Chato Chand Ongar Deep Hand pumps 86 & Shallow Hand Pumps 23 Nos).

- 1 Boring of Tube Well in water bearing soil from ground level upto 100ft depth i/c sinking and with drawing and casing pipes (PHSINO. 1P/36)

1,955 @ 414.00 Per rft = Rs 809,370

- 2 Supplying and Installing PVC Blind pipe "C" Class approved designed quality and make i/c necessary sockets etc complete (PHSINO. 11P/14 & PHSMINO. 16P/111)

1,265 @ 212.10 Per rft = Rs 268,307

- 3 Supplying and Installing PVC Strainer Pipe "B" Class of approved design quality including necessary sockets etc complete (PHSINO. P43)

690 @ 242.95 Per rft = Rs 167,636

- 4 Shrouding with Graded Bajri (3/8" to 1/8" or 9 to 3mm) in between bore and blind pipe for the following diameter or strainer (PHSINO. 13P/35)

1,955 @ 49.00 Per rft = Rs 95,795

- 5 Providing pvc pipe of class "D" ( equivalent make) fixing in tranches I/C cutting, fitting and jointing with z joints with one rubber ring including testing with water to head of one 122 meters or 400 ft (PHSI No. 6D P/24)

1,610 @ 33.00 Per rft = Rs 53,130

- 6 Construction of CC Platform inside 4' x 4' with 1/2" Thick Wall and CC drain in length 10' (Based on scheduled rate)

23 @ 6691.00 Per rft = Rs 153,893

- 7 Suppling and fixing shallow community hand pump (ABYER NO.06) machine (market rate)

23 @ 6800 each = Rs 156400  
Total Cost 170433

  
Civil Engineer  
PDMA Sindh

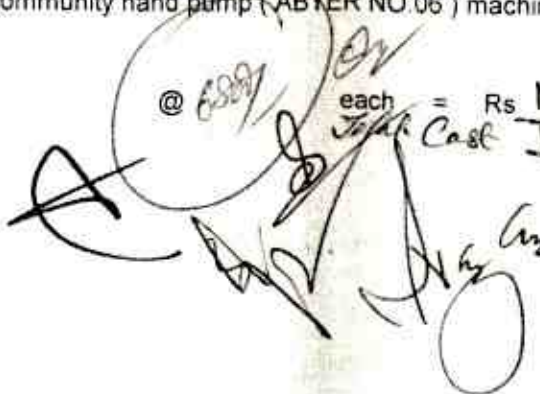
  
Director Operation  
PDMA Sindh

# DEEP HAND PUMP

KOHISTAN AREA OF THATTA DISTRICT

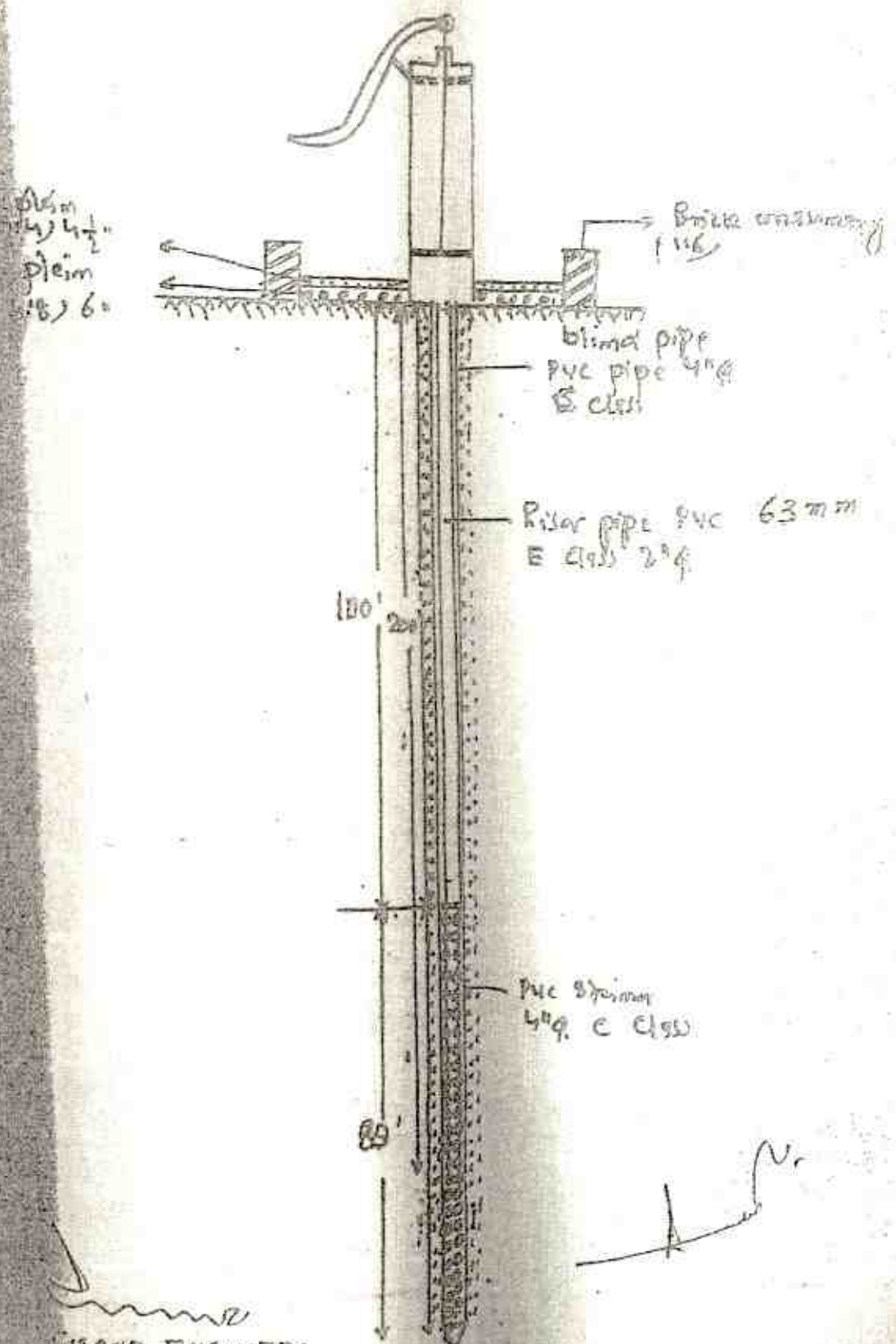

CONSULT ENGINEER  
HAYAT

PLAN AND SECTION OF PLATE FORM FOR HAND PUMP

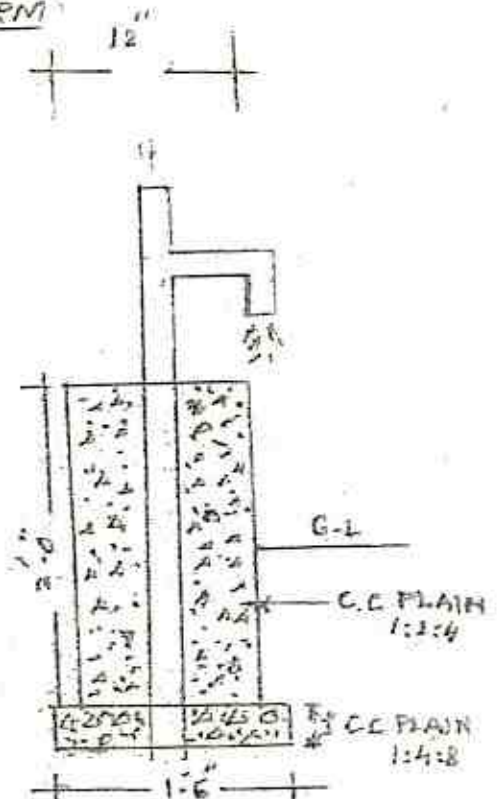
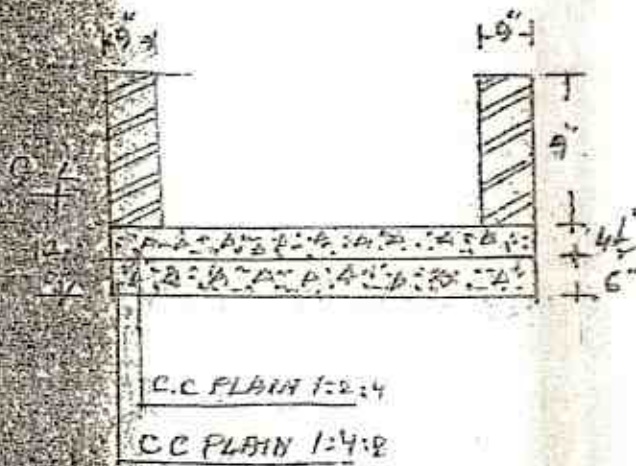

SECTION OF C.C. HAND PUMP

SECTION OF PLAT FORM

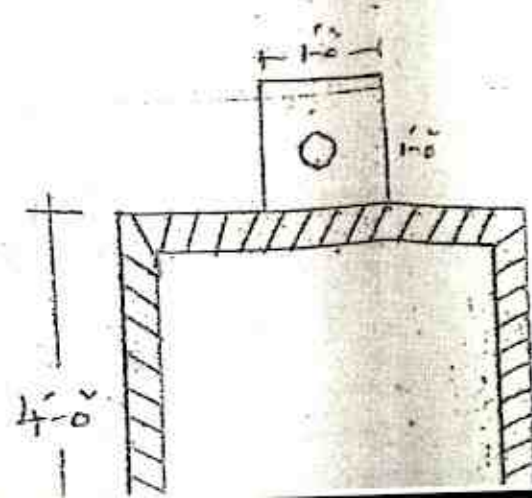

*[Handwritten signature]*

# SHALLOW HAND PUMP

## KOHISTAN AREA OF THATTA DISTRICT

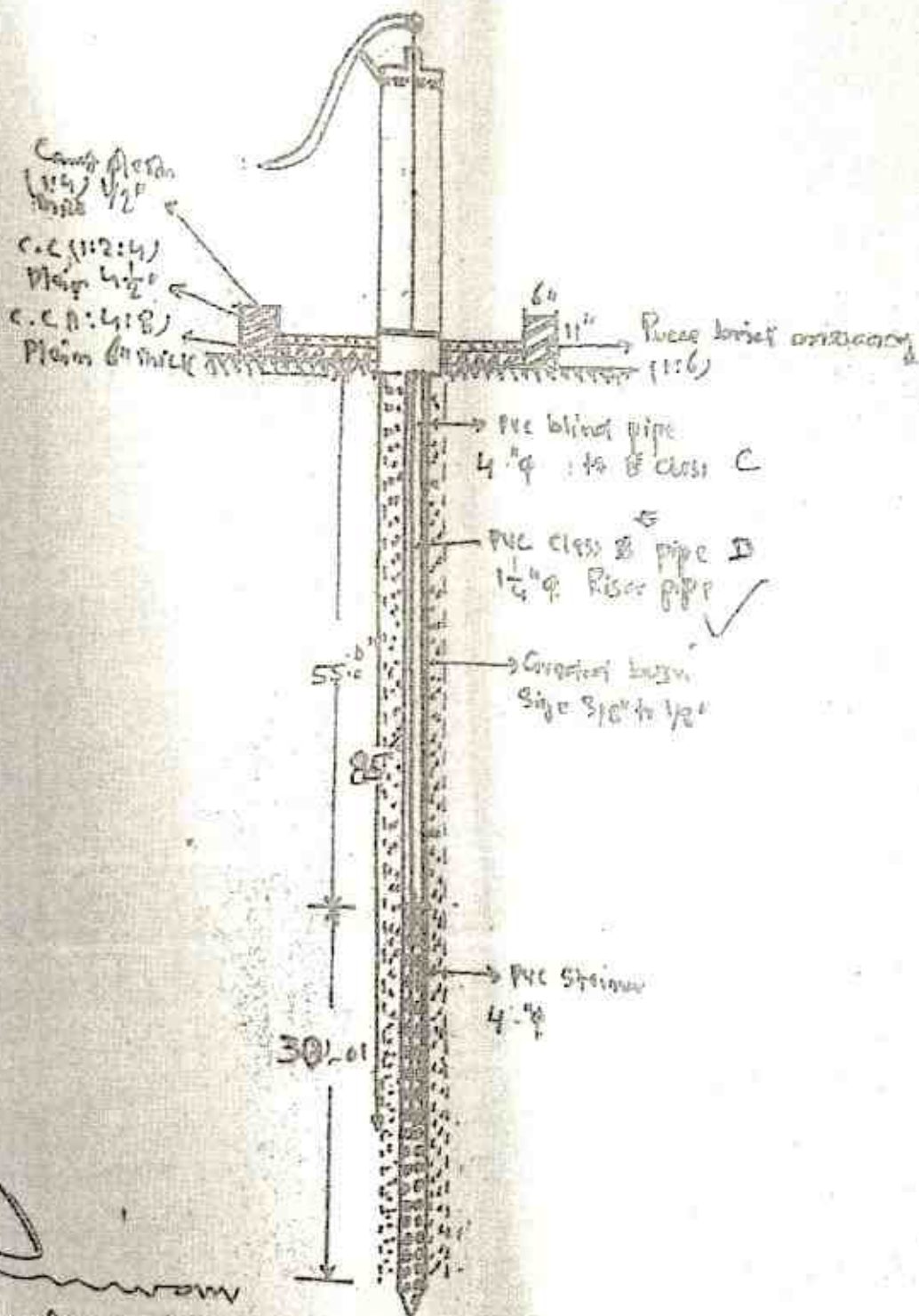

  
 CIVIL ENGINEER  
 P. 1111

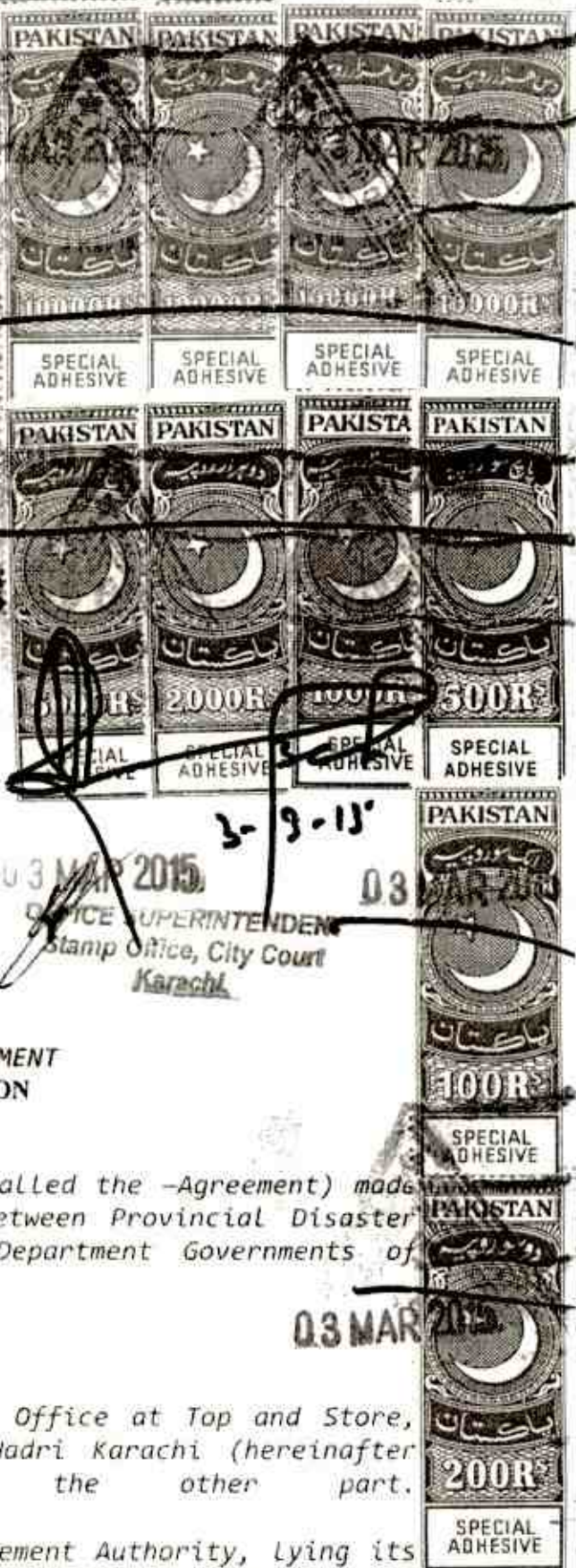

IKANDAR IMRAN STAMP VENDOR

Office No. 19, City Court Karachi

29659

No. DATE .....

SUED TO WITH ADDRESS .....

THROUGH WITH ADDRESS *M/S. NAVEET MAL*

PURPOSE .....

VALUE RS (ATTESTED) .....

STAMP VENDOR'S SIGNATURE *[Signature]*

16 FEB 2015

03 MAR 2015

3-9-15

03

OFFICE SUPERINTENDENT  
Stamp Office, City Court  
Karachi

FORM OF CONTRACT AGREEMENT  
SUM OF RS.16.248-MILLION

THIS CONTRACT AGREEMENT (hereinafter called the -Agreement) made on the 23rd day of February, 2015 between Provincial Disaster Management Authority Rehabilitation Department Governments of Sindh Karachi

And

M/S Naveet Mal Government Contractor, Office at Top and Store, Bolani Muhalla Jamoot Para Ibrahim Hadri Karachi (hereinafter called the Contractor) of the other part.

WHEREAS, the Provincial Disaster Management Authority, lying its office in Bungalow No. 40, Street No.24 Khayaban-e- Mujahid DHA Phase V Karachi, is desirous certain work" Viz PROVISION AND INSTALLATION OF DEEP HAND PUMPS IN KOHISTAN AREA OF UNION COUNCIL JUNGSHAHI, CHATO CHAND & ONGAR TALUKA & DISTRICT THATTA ( DEEP HAND PUMPS 86- NOS & SHALLOW HAND PUMPS 23 NOS" Should be executed & completed by the contractor and has accepted a bid, by the contractor for the execution and completion of the work and the remedying of any defects therein.

NOW this Agreement witnesses as follows:

1. In this Agreement words and expressions shall have the same meanings as are respectively assigned to them in the Conditions of Contract hereinafter referred to.

*[Handwritten signatures and stamps]*  
M/S NEVAT MAL  
Govt. Contractor  
Proprietor

2. The following documents after incorporating addenda, ( if any) except those parts relating to Instructions to Bidders, shall be deemed to form and be read and construed as an integrated part of this Agreement, viz:

- (a) The Letter of Acceptance; ( Annex-I)
- (b) The completed Form of Bid along with Schedules to Bid; (Annex-II)
- (c) Conditions of Contract & Contract Data ;( Annex-III)
- (d) The priced Schedule of Prices/Bill of quantities (BOQ); (Annex-IV)
- (e) The Specifications; (Annex-V) and
- (f) The Drawings (Annex-VI)
- (g) General Condition

- (i) In case of any variation in provisions of Schedule-B - as per accepted tender and technically sanction detailed working estimate, the execution of work shall be regulated in accordance with the provisions as per technically sanctioned working estimate.
- (ii) No Premium shall be allowed on Non-Schedule Items.
- (iii) The payment is not made to the firm, if the water does not comes after boring.
- (iv) No separate payment for carriage of material will be allowed.
- (v) ALL Material required in connection of the subjected work shall be procured and brought at site by the Contractor at his own cost.
- (vi) No Payment of extra items shall be made unless written order is given by the Undersigned for execution of the extra items and approved by the competent authority.
- (vii) Income tax shall be deducted from the bills on the above values of work done and paid for as per Latest order of competent authority in this regard.
- (viii) The Sales tax invoice on taxable items should be provided to this office for record.
- (ix) Sweet & palatable water only shall have to be used in construction work which is to be arranged by the contractor.
- (x) The Arbitration clause from the agreement stands deleted.
- (xi) The work must be carried out as per PWD/PHE specifications.
- (xii) The successful bidder shall furnish 5% performance security of contract value, in the shape of bank guarantee to procuring agency within the period of (14) Fourteen days of the receipt of letter of acceptance of work order.

3. In consideration of the payments to be made by the Procuring Agency to the Contractor as hereinafter mentioned, the Contractor hereby covenants with the Procuring Agency to execute and complete the Works and remedy defects therein in conformity and in all respects within the provisions of the Contract.

4. The Procuring Agency hereby covenants to pay the Contractor, in consideration of the execution and completion of the Works as per provisions of the Contract, the Contract Price or such other sum as may become payable



M/S NEVAT ALIAS  
Govt. Contractor  
Propositor

under the provisions of the Contract at the times and in the manner prescribed by the Contract.

5. Now withstanding anything contained to the contrary or conflict with the provision of this agreement in any of the documents mentioned in clause 1, above the provision of this agreement shall prevail and the documents mentioned above, shall be deemed to have been amended to the extent of inconsistency found therein, by the provision of this agreement, in case of inconsistency between any of the document referred to herein, the later documents shall prevail and the tender documents shall be constructed to have been amended to that extent.

6. this contract shall not be transferable or assignable in whole or part of any of parties hereto, provided that the owner may assign his rights and obligations in whole or in part or any other company which shall be entirely owned Company belonging to the same group of the companies as the owner, in such as event touch other company shall be either to act to as owner under this contract.

IN WITNESS WHEREOF the parties hereto have caused this Contract Agreement to be executed on the day, month and year first before written in accordance with their respective Laws.

  
NAVEET MAL  
GOVERNMENT CONTRACTOR



  
NAZAM MUHAMMAD BOZDAR  
DIRECTOR (F&A)  
PDMA, SINDH



Signed, Sealed and Delivered in the presence of:

Witness:  
Signature   
Name Dilip Kumar  
Title: \_\_\_\_\_  
CNIC: 4234-197903-1

Witness:  
Signature   
Name Anil Kumar Senani  
Title: Assistant Director  
CNIC: 42201-7942651-5



OFFICE OF THE PROVINCIAL DISASTER MANAGEMENT AUTHORITY KARACHI

1

Tender Form issued to M/S: B.S. Traders & Engineering Services Government Contractor.

Charge to Rs:-3000/= Vide D.R No: 084470.50 Dated the:- 08/01/2015

*[Signature]*  
DIRECTOR FINANCE (PDMA)  
GOVERNMENT OF SINDH KARACHI

**NAME OF WORK:-** PROVISION AND INSTALATION OF HAND DEEP PUMP AT KOHISTAN AREAS IN DISTRICT JAMSHORO TALUKA BULA KHAN UNION COUNCIL TONG (DEEP HAND PUMP 15-NOS)

I/We hereby tender for execution of the works of Government of Sindh herein before/after referred to as Government of the work specification in the written memorandum with time specification in each memorandum at:-

I. *[Signature]*  
Civil Work

*[Signature]* / At PMS % At Par/Above/Below

(CONTRACTOR SIGNATURE)

*[Signature]*  
DIRECTOR FINANCE (PDMA)  
GOVERNMENT OF SINDH KARACHI

The estimate carried out & according to all respect with the specification design/drawing & instruction in writing referred to rule-I here of the clause-12 of the annexed condition of the contract & agreement that when material for the work are provided by the Govt: such material & rate to paid for then shall be as provided in Schedule 'B' here to:-

**GENERAL DESCRIPTION**

i.	Estimated Cost	Rs:-27.443-Million
ii.	Earnest Money 2%	Rs:-0.548-Million
iii.	S/Deposit in/c: E/Money 10%	Rs:-Million
iv.	Income Tax will be deducted 7%	Rs:-1.921-Million
v.	Time of Completion of Work:-	Rs:-03-Months

I/We have offered the above rates after taking into consideration all the terms & conditions as per B-I printed tender & this form so as to completed the agreement, In case of Failure the Department will be at liberty to take action me /us.

BIDDING DACUMENTS/BOQ

Attached herewith

Call Deposit/Pay order bearing No: 0049680 Dated:- 13/01/2015  
Amounting to Rs:- 543500/- Bank Sindh Bank Branch Karachi  
Is enclosed herewith as desired on account of Security Deposit

*[Signature]*  
**B.S Traders & Engineering Services**  
(CONTRACTOR SIGNATURE)



## SCHEDULE "B"

Name of work:- Provision and Installation of hand pump at Kohistan area in District Jamshoro Taluka Thano Bala Khan Union Council Tong (Deep Hand pump).

- |    |  |           |              |              |                            |
|----|--|-----------|--------------|--------------|----------------------------|
| 1. | Boring of Tube Well in water bearing soil from ground level upto 100ft depth i/c sinking and with drawing and casing pipes (PHSINo. 1P/36).  | 15500 Rft | @ Rs.414/-   | Per Rft =    | Rs:-64,17,000/✓            |
| 2. | Boring of Tube Well in water bearing soil from depth 101' to 200' below ground level i/c sinking and with drawing and casing pipes (PHSINo. 2P/42).  | 12400 Rft | @ Rs.516/-   | Per Rft =    | Rs:-639,800/-<br>6398400/2 |
| 3. | Supplying and Installing PVC Blind pipe "C" Class approved designed quality and make i/c necessary sockets etc complete (PHSINo. 11P/14 & PHSMINo. 16P/111).   | 15500 Rft | @ Rs.212/10  | Per Rft =    | Rs:-32,87,550/✓            |
| 4. | Supplying and Installing PVC Strainer Pipe "C" Class of approved design quality including necessary sockets etc complete.(PHSINo.9b P/43).   | 12400 Rft | @ Rs.242/95  | Per Rft =    | Rs:-30,12,580 ✓            |
| 5. | Shrouding with Graded Bajri (3/8" to 1/8" or 9 to 3mm) in between bore and blind pipe for the following diameter or strainer (PHSINo. 13P/35).   | 13950Rft  | @ Rs.49/-    | Per Rft =    | Rs:-683,550/-✓             |
| 6. | Construction of CC Platform inside 4' x 4' with 1/2" Thick Wall and CC drain in length 10' (Based on scheduled rate).  | 155-Nos   | @ Rs.-6691/- | Each =       | Rs:-10,37,105/-✓           |
|    |  |           |              | Total Rupees | Rs. 20836185/2             |
| 7. | Supplying installing Rising with one end socket factor Standar DS 3505 Pipe material UPVC class "E" pipe pressure 15 Bars wall thickness 4.7 mm dia 63 mm (Rate approved)  | 23250 Rft | @ Rs. 66/4   | Per Rft =    | Rs. 1534500/2              |
| 8. | Supplying, Installing and Testing Deep hand pump pipe machine suitable for Kohistan area superior quality make as per site requirement i.e including all required accessories, i.e Labor Charges for lowering the hand pump. | 155 Nos   | Rs. 24500/-  | Each =       | Rs. 3797500/               |

Total Cost

Rs. 26168185/

Say Rs 26.168-Million

**TERMS AND CONDITIONS**

1. Arbitration clause stands deleted from the agreement.
2. Any typographical errors in the schedule "B" are subject to correction with the reference to the schedule of rates General item 2012 in force -10-2012 as approved by the standing rates Committee Sindh, Karachi.
3. Water shall be arranged by the contractor at site of work without any extra payment.
4. No premium shall be paid on non-Schedule items.
5. No Cartage or any item of material either supplied by the Department or arranged by the Contractor shall be paid.
6. Contractor has to bring sample of the material and handed to the Engineer in charged free of cost.
7. All buildings debries& surplus stuff not req. for use construction shall be removed from the site and suitable disposed off by the contractor for which no extra cartages shall be paid.
8. This work will be carried out as per PWD Specifications.

CIVIL ENGINEER (PDMA)

DIRECTOR FINANCE (PDMA)

DEEP HAND PUMP  
KOHISTAN AREA OF THATTÁ DISTRICT

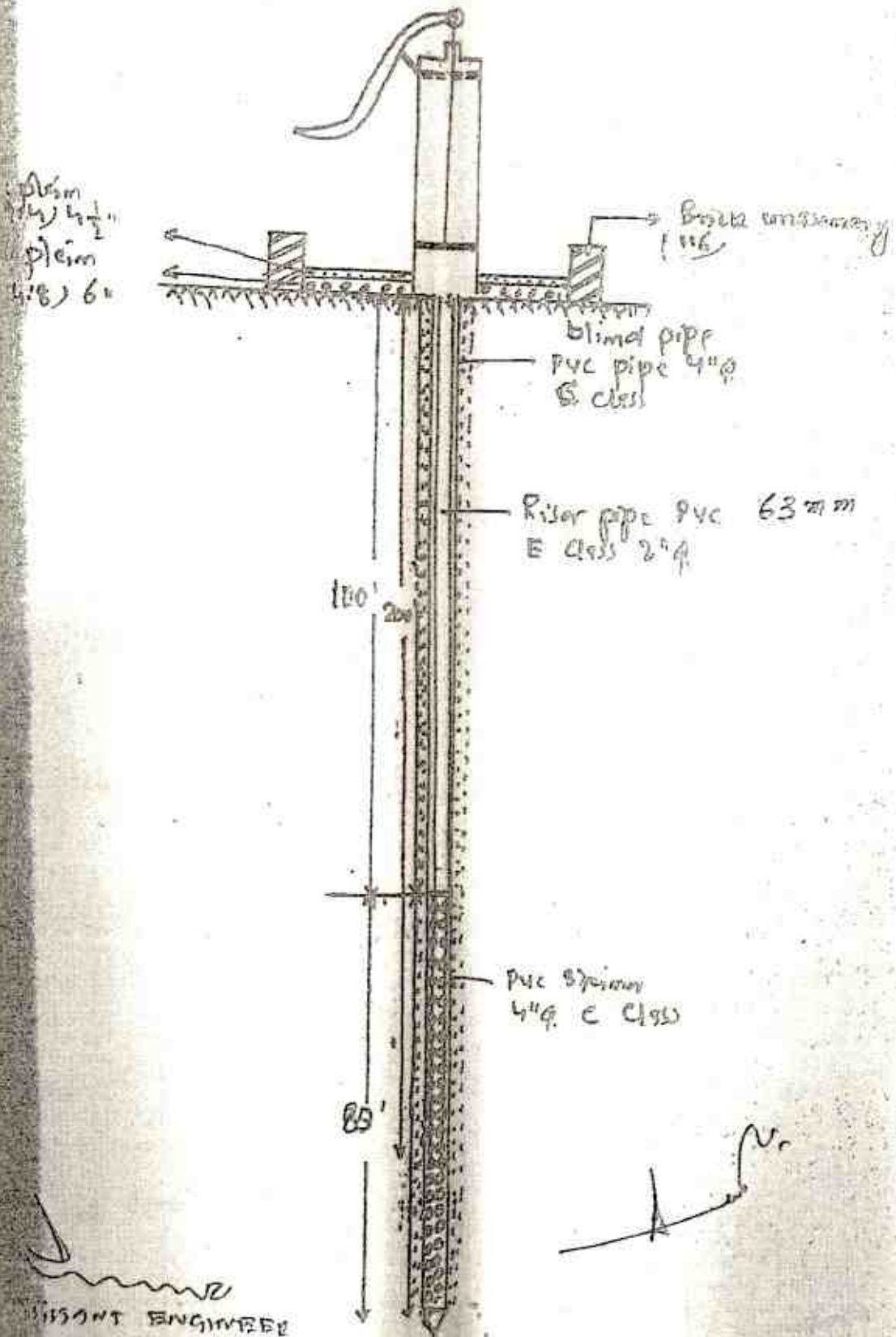

ASSISTANT ENGINEER  
AT HANSAH ENGLISH

PLAN AND SECTION OF PLATE FORM FOR HAND PUMP

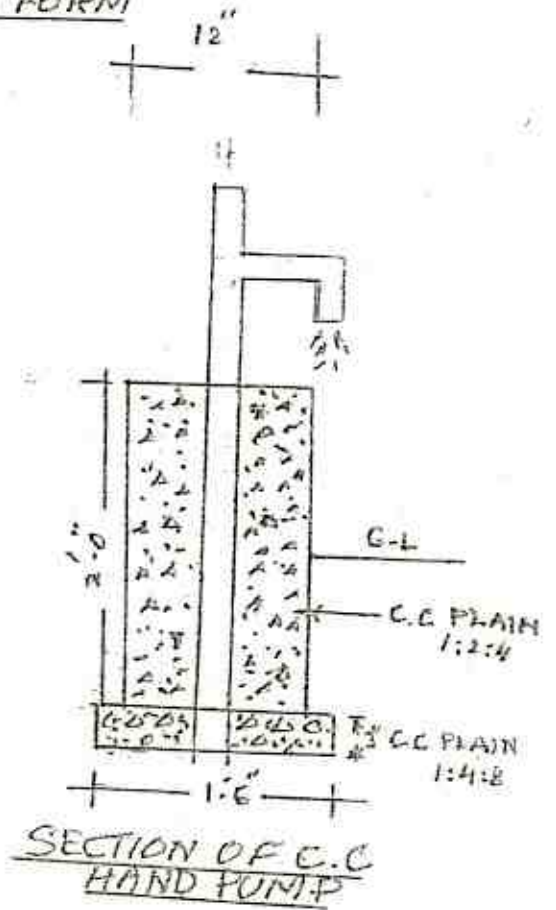
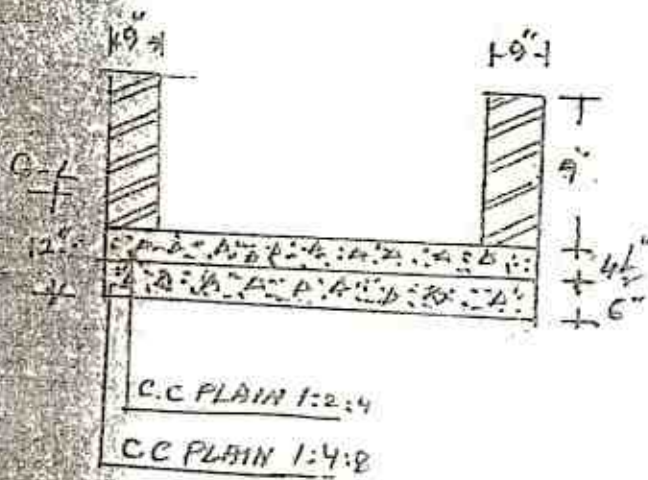

SECTION OF PLAT FORM.

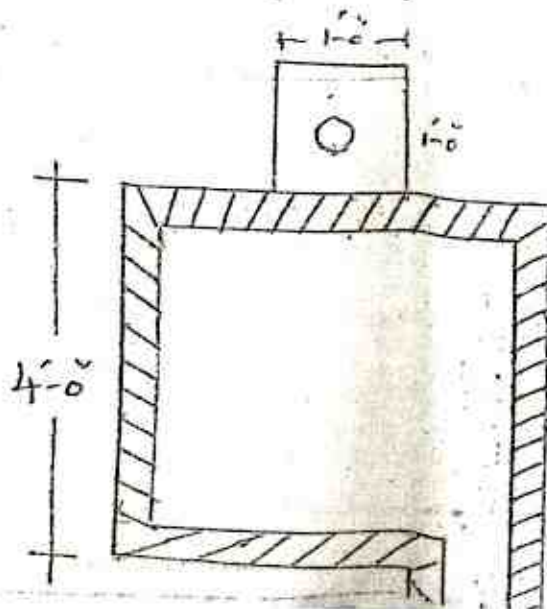

*[Handwritten signature]*

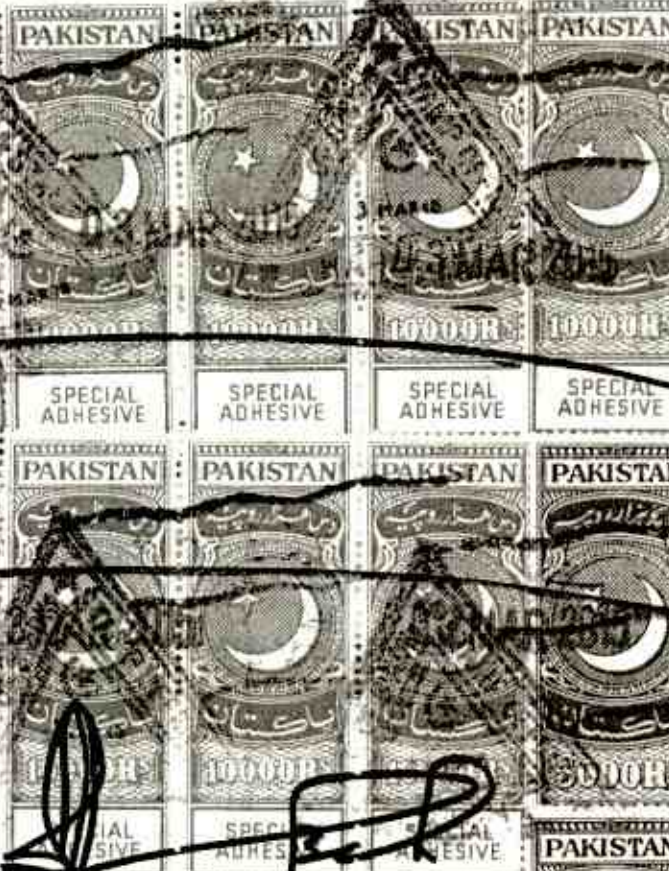

SIKANDAR IMRAN STAMP VENDOR  
 Licence No. 88, Seat No. 19, City Court Karachi  
 S No: 29711 DATE .....  
 ISSUED TO WITH ADDRESS .....  
 THROUGH WITH ADDRESS M/s. B.S. Traders  
 PURPOSE .....  
 VALUE RS ..... ATTESTED .....  
 STAMP VENDOR'S SIGNATURE .....

16 FEB 2015

*[Handwritten signature]*  
 3-3-15  
 Stamp Vendor's Court  
 Karachi

03 MAR 2015

**FORM OF CONTRACT AGREEMENT  
 SUM OF RS.26.168-MILLION**

THIS CONTRACT AGREEMENT (hereinafter called the -Agreement) made on the 23rd day of February, 2015 between Provincial Disaster Management Authority Rehabilitation Department Governments of Sindh Karachi

And

M/S B.S. Traders & Engineering Services Government Contractor, Office at House No:39 Rehman Town Jamnadas Colony Phase-II Mirpurkhas (hereinafter called the Contractor) of the other part

*[Handwritten signature]*



**B.S Traders  
 & Engineering Services**

M/S B.S. Traders & Engineering Services, the Provincial Disaster Management Authority, lying its office in Bungalow No. 40, Street No.24 Khayaban-e- Mujahid DHA Phase V Karachi, is desirous certain work" Viz PROVISION AND INSTALLATION OF DEEP HAND PUMPS IN KOHISTAN AREA IN DISTRICT JAMSHORO TALUKA THANA BULA KHAN UNION COUNCIL TONG (DEEP HAND PUMPS 155-Nos) Should be executed & completed by the contractor and has accepted a bid, by the contractor for the execution and completion of the work and the remedying of any defects therein.

NOW this Agreement witnesses as follows:

1. In this Agreement words and expressions shall have the same meanings as are respectively assigned to them in the Conditions of Contract hereinafter referred to.



2. The following documents after incorporating addenda, (if any) except those parts relating to Instructions to Bidders, shall be deemed to form and be read and construed as an integrated part of this Agreement, viz:

- (a) The Letter of Acceptance; (Annex-I)
- (b) The completed Form of Bid along with Schedules to Bid; (Annex-II)
- (c) Conditions of Contract & Contract Data ;( Annex-III)
- (d) The priced Schedule of Prices/Bill of quantities (BOQ); (Annex-IV)
- (e) The Specifications; (Annex-V) and
- (f) The Drawings (Annex-VI)
- (g) General Condition

- (i) In case of any variation in provisions of Schedule-B - as per accepted tender and technically sanction detailed working estimate, the execution of work shall be regulated in accordance with the provisions as per technically sanctioned working estimate.
- (ii) No Premium shall be allowed on Non-Schedule Items.
- (iii) The payment is not made to the firm, if the water does not comes after boring.
- (iv) No separate payment for carriage of material will be allowed.
- (v) All Material required in connection of the subjected work shall be procured and brought at site by the Contractor at his own cost.
- (vi) No Payment of extra items shall be made unless written order is given by the Undersigned for execution of the extra items and approved by the competent authority.
- (vii) Income tax shall be deducted from the bills on the above values of work done and paid for as per latest order of competent authority in this regard.
- (viii) The Sales tax invoice on taxable items should be provided to this office for record.
- (ix) Sweet & palatable water only shall have to be used in construction work which is to be arranged by the contractor.
- (x) The Arbitration clause from the agreement stands deleted.
- (xi) The work must be carried out as per PWD/PHE specifications.
- (xii) The successful bidder shall furnish 5% performance security of contract value, in the shape of bank guarantee to procuring agency within the period of (14) Fourteen days of the receipt of letter of acceptance of work order.

3. In consideration of the payments to be made by the Procuring Agency to the Contractor as hereinafter mentioned, the Contractor hereby covenants with the Procuring Agency to execute and complete the works and remedy defects therein in conformity and in all respects within the provisions of the Contract.

4. The Procuring Agency hereby covenants to pay the Contractor, in consideration of the execution and completion of the Works as per provisions of the Contract, the Contract Price or such other sum as may become payable



**B.S Traders**  
& Engineering Services

under the provisions of the Contract at the times and in the manner prescribed by the Contract.

5. Now withstanding anything contained to the contrary or conflict with the provision of this agreement in any of the documents mentioned in clause 1, above the provision of this agreement shall prevail and the documents mentioned above, shall be deemed to have been amended to the extent of inconsistency found therein, by the provision of this agreement, in case of inconsistency between any of the document referred to herein, the Later documents shall prevail and the tender documents shall be constructed to have been amended to that extend.

6. this contract shall not be transferable or assignable in whole or part of any of parties hereto, provided that the owner may assign his rights and obligations in whole or in part or any other company which shall be entirely owned Company belonging to the same group of the companies as the owner, in such as event touch other company shall be either to act to as owner under this contract .

IN WITNESS WHEREOF the parties hereto have caused this Contract Agreement to be executed on the day, month and year first written in accordance with their respective laws.



**B.S. TRADERS & ENGINEERING SERVICES**  
**GOVERNMENT CONTRACTOR**

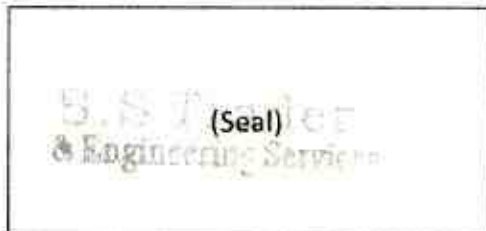

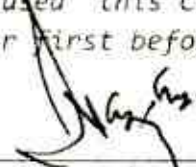

**NAZAR MUHAMMAD BOZDAR**  
**DIRECTOR (F&A)**  
**PDMA, SINDH**



Signed, Sealed and Delivered in the presence of:

Witness:

Signature 

Name Lekheraj

Title: \_\_\_\_\_

CNIC: 42501-3887896-1

Witness:

Signature 

Name Ajay Kumar

Title: Assistant Director

CNIC: 42201-7942551-5



OFFICE OF THE PROVINCIAL DISASTER MANAGEMENT AUTHORITY KARACHI

(7)

Tender Form issued to M/S: Modern Engineering Works Government Contractor.

Charge to Rs:-3000/= Vide D.R No: 03467054 Dated the: 08/01/2015

  
DIRECTOR FINANCE (PDMA)  
GOVERNMENT OF SINDH KARACHI

NAME OF WORK:- PROVISION AND INSTALATION OF HAND DEEP PUMP AT KOHISTAN AREAS IN DISTRICT DADU TALUKA JOHI UNION COUNCIL TOOR, SAWARO, CHANNI, PHULJI, AND TR KHAN(DEEP HAND PUMP 163-NOS)

I/We hereby tender for execution of the works of Government of Sindh herein before/after referred to as Government of the work specification in the written memorandum with time specification in each memorandum at:-

I. Civil Work

 1. At Par % At Par/Above/Below

  
(CONTRACTOR SIGNATURE)

**Modern Engineering Works**  
**Modern Engineering Works**

  
DIRECTOR FINANCE (PDMA)  
GOVERNMENT OF SINDH KARACHI

The estimate carried out & according to all respect with the specification design/drawing & instruction in writing referred to rule-1 here of the clause-12 of the annexed condition of the contract & agreement that when material for the work are provided by the Govt: such material & rate to paid for then shall be as provided in Schedule 'B' here to:-

GENERAL DESCRIPTION

i.	Estimated Cost	Rs:-28.57-Million
ii.	Earnest Money 2%	Rs:-0.571-Million
iii.	S/Deposit in/c: E/Money 10%	Rs:-2.857-Million
iv.	Income Tax will be deducted 7%	Rs:-1.999-Million
v.	Time of Completion of Work:-	Rs:-03-Months

I/We have offered the above rates after taking into consideration all the terms & conditions as per B-1 printed tender & this form so as to completed the agreement, In case of Failure the Department will be at liberty to take action me /us.

BIDDING DOCUMENTS/BOQ

Attached herewith

Call Deposit/Pay order bearing No: 0012462 Dated: 12/01/2015  
Amounting to Rs:- 570500/- Bank ASKOSI Bank Branch Karachi  
Is enclosed herewith as desired on account of Security Deposit

  
(CONTRACTOR SIGNATURE)

**Modern Engineering Works**

**Bill of Quantities**

**Name of work:-** Provision and Installation of hand pump at Kohistan area in District Dadu Taluka Johi U/C Toor, Sawaro, Channi, Phulji and TR Khan (Deep Hand Pump 163Nos)

1. Boring of Tube Well in water bearing soil from ground level up to 100ft depth i/c sinking and with drawing and casing pipes (PHSINo. 1P/36).  
 16300-Rft @ Rs.414.00 PerRft Rs:-6748200/- ✓
2. Boring of Tube Well in water bearing soil from depth 101' to 200' below ground level i/c sinking and with drawing and casing pipes (PHSINo. 2P/42).  
 13040 Rft @ Rs.516.00 PerRft Rs:-6728640 ✓
3. Supplying and Installing PVC Blind pipe "C" Class approved designed quality and make i/c necessary sockets etc complete (PHSINo. 11P/14 & PHSMINo. 16P/111).  
 16300-Rft @ Rs.212.10 PerRft Rs:-3457230 ✓
4. Supplying and Installing PVC Strainer Pipe "C" Class of approved design quality including necessary sockets etc complete. (PHSINo. 9b P/43).  
 13040 Rft @ Rs.242.95 PerRft Rs:-31,68,068 ✓
5. Shrouding with Graded Bajri (3/8" to 1/8" or 9 to 3mm) in between bore and blind pipe for the following diameter or strainer (PHSINo. 13P/35).  
 14670-Rft @ Rs.49.00 PerRft Rs:-718830/-  
 Rs:-4124700/- ✓
6. Construction of CC Platform inside 4' x 4' with 1/2" Thick Wall and CC drain in length 10' (Based on scheduled rate)  
 163-Nos @ Rs.6691/= each Rs:-10,90,633/-  
**Total Rupees:-** 21911601/-
7. Supplying installing Rising with one end socket factor Standard DS 3505 Pipe material UPVC class 'E' pipe pressure 15 Bars wall thickness 4.7 mm dia 63 mm (Rate approved)  
 24450 Rft @ Rs. 66/- Per Rft Rs. 1613700/-
8. Supplying, Installing and Testing Deep hand pump pipe machine suitable for Kohistan area superior quality make as per site requirement i.e. including all required accessories, i.e. Labor Charges for lowering the hand pump.  
 163-Nos @ Rs. 24500 Each Rs. 3993500/-

**TERMS AND CONDITIONS :**

Arbitration clause stands deleted from the agreement.  
 Any typographical errors in the schedule "B" are subject to correction with the reference to the schedule of rates General item 2012 in force -10-2012 as approved by the standing rates Committee Sindh,  
 Total Cost - Rs. 27518801/-  
 Rs. 5607200/- Cost of N.S.I. items  
 Sign: 27.5/8  
 Mollion



Karachi.

100 % well graded crushed bajri shall be used in item of RCC 1:24

Water shall be arranged by the contractor at site of work without any extra payment.

No premium shall be paid on non-Schedule items.

No Cartage or any item of material either supplied by the Department or arranged by the Contractor shall be paid.

C.C. Block shall be machine made.

Contractor has to bring sample of material and handed over to the Engineer In-charge

The work will be carried out as per PWD Specification.

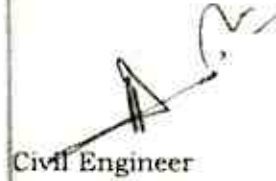

Civil Engineer

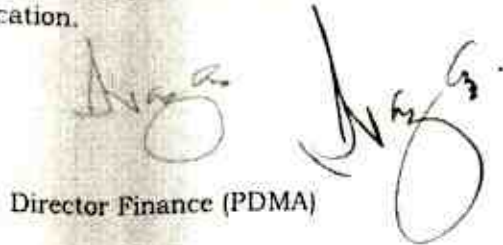

Director Finance (PDMA)

DEEP HAND PUMP  
KOHISTAN AREA OF THATTA DISTRICT

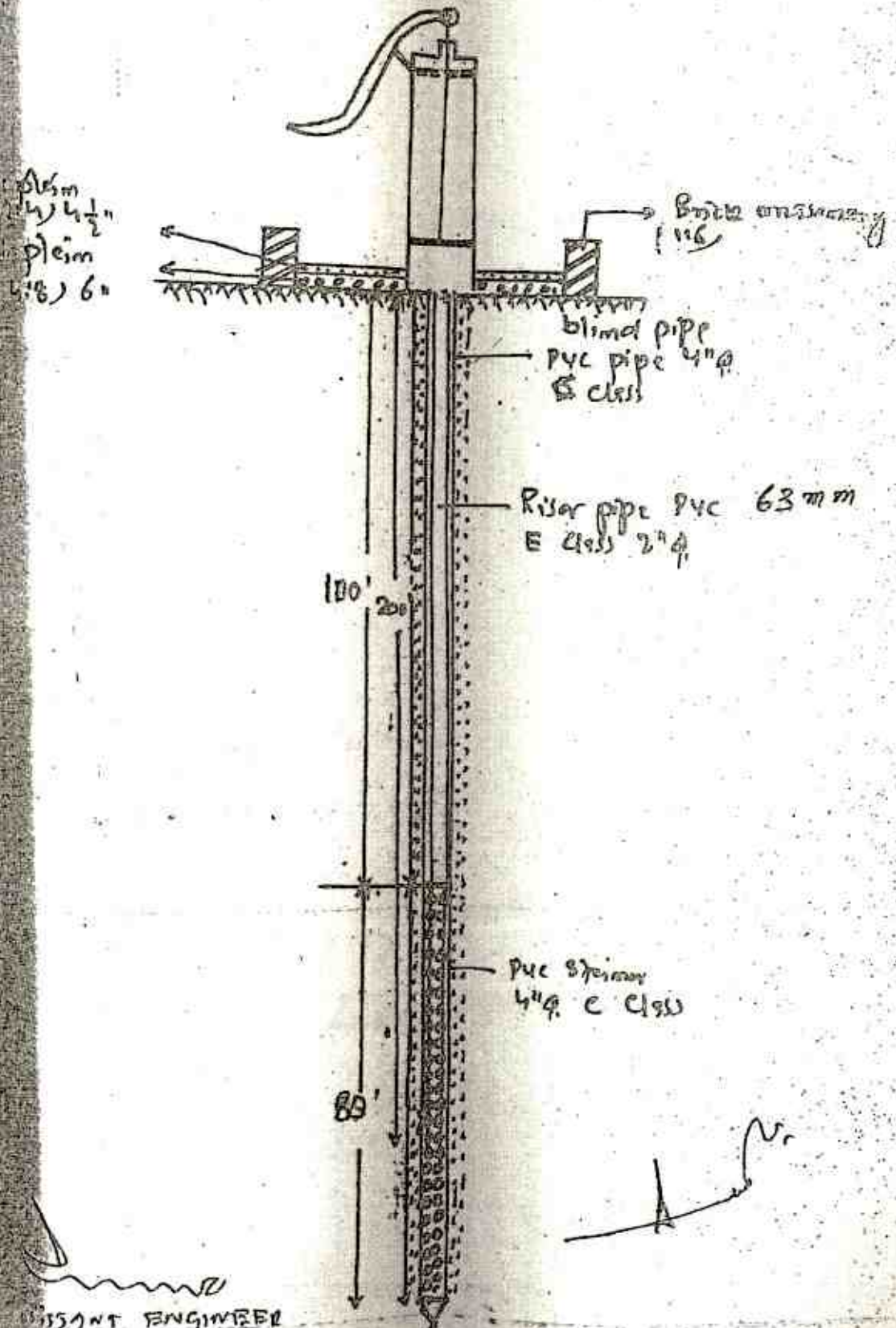

ASSANT ENGINEER  
 IN HONORARY ENGINEERING

PLAN AND SECTION OF PLATE FORM FOR HAND PUMP

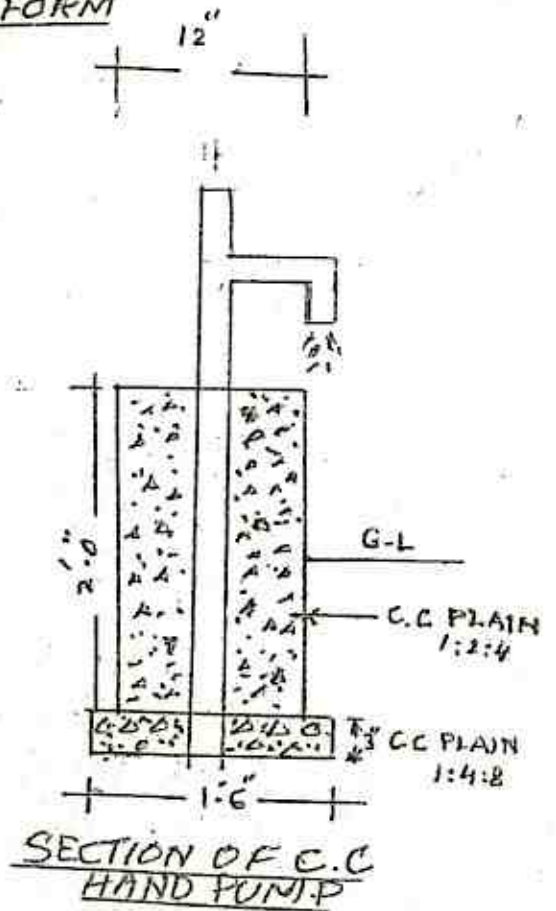
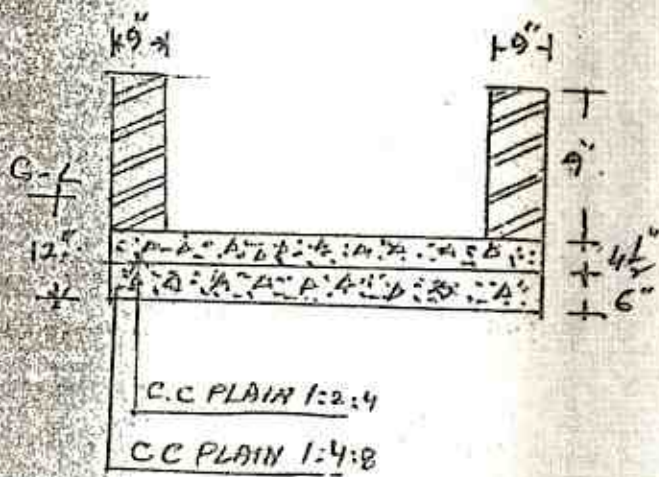

SECTION OF PLAT FORM.

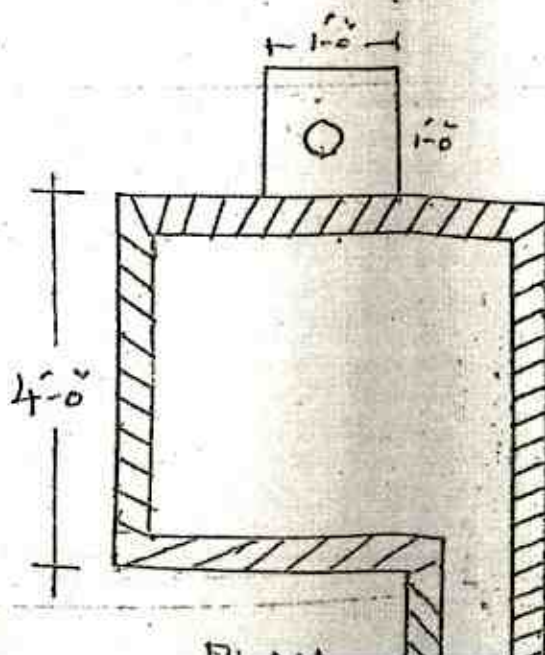

*[Handwritten signature]*

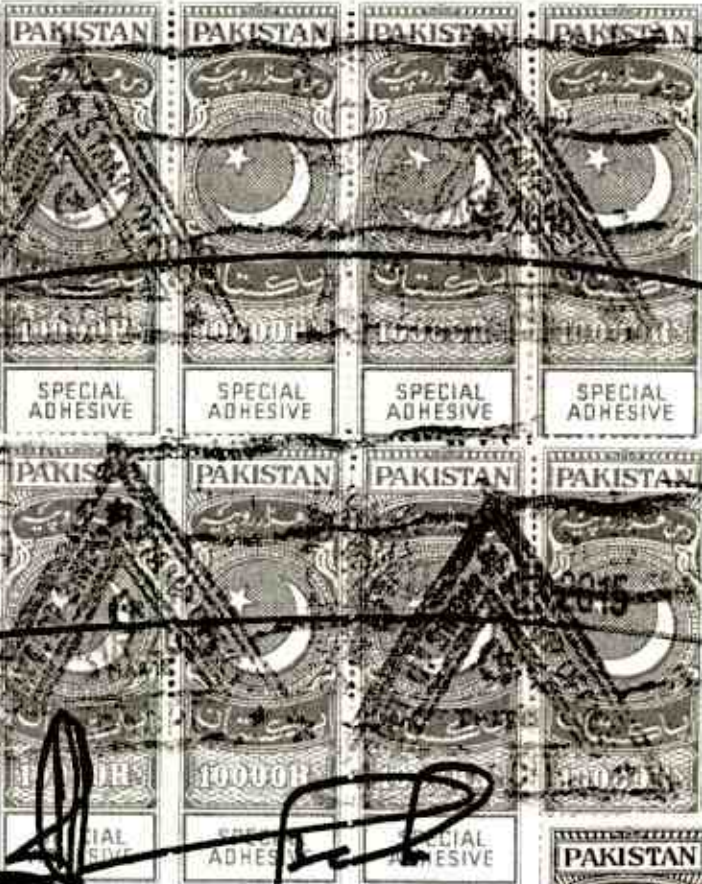

KANDAR IMRAN STAMP VENDOR  
29730

16 FEB 2015

M/S. Modern Engin

OFFICE SUPERINTENDENT  
Stamp Office, City Comm  
Karachi.

03 MAR 2015

03 MAR

FORM OF CONTRACT AGREEMENT  
SUM OF RS.27.518-MILLION

THIS CONTRACT AGREEMENT (hereinafter called the -Agreement) made on the 23rd day of February, 2015 between Provincial Disaster Management Authority Rehabilitation Department Governments of Sindh Karachi

And

M/S Modern Engineering Works Government Contractor, Office -11 Haji Wali Muhammad Arcade Centre Doctor Line Saddar Hyderabad (hereinafter called the Contractor) of the other part



WHEREAS, the Provincial Disaster Management Authority, lying its office in Bungalow No. 40, Street No.24 Khayaban-e- Mujahid DHA Phase V Karachi, is desirous certain work" Viz PROVISION AND INSTALLATION OF DEEP HAND PUMPS IN KOHISTAN AREA IN DISTRICT DADU TALUKA JOHI UNION COUNCIL TOOR SAWARO CHANNI, PHULJI AND TR KHAN (DEEP HAND PUMPS 163-Nos) Should be executed & completed by the contractor and has accepted a bid, by the contractor for the execution and completion of the work and the remedying of any defects therein.

NOW this Agreement witnesses as follows:

- 1. In this Agreement words and expressions shall have the same meanings as are respectively assigned to them in the Conditions of Contract hereinafter referred to.

Modern Engineering Works



2. The following documents after incorporating addenda, ( if any) except those parts relating to Instructions to Bidders, shall be deemed to form and be read and construed as an integrated part of this Agreement, viz:

- (a) The Letter of Acceptance; ( Annex-I)
- (b) The completed Form of Bid along with Schedules to Bid; (Annex-II)
- (c) Conditions of Contract & Contract Data ;( Annex-III)
- (d) The priced Schedule of Prices/Bill of quantities (BOQ); (Annex-IV)
- (e) The Specifications; (Annex-V) and
- (f) The Drawings (Annex-VI)
- (g) General Condition

- (i) In case of any variation in provisions of Schedule-B - as per accepted tender and technically sanction detailed working estimate, the execution of work shall be regulated in accordance with the provisions as per technically sanctioned working estimate.
- (ii) No Premium shall be allowed on Non-Schedule Items.
- (iii) The payment is not made to the firm, if the water does not comes after boring.
- (iv) No separate payment for carriage of material will be allowed.
- (v) ALL Material required in connection of the subjected work shall be procured and brought at site by the Contractor at his own cost.
- (vi) No Payment of extra items shall be made unless written order is given by the Undersigned for execution of the extra items and approved by the competent authority.
- (vii) Income tax shall be deducted from the bills on the above values of work done and paid for as per Latest order of competent authority in this regard.
- (viii) The Sales tax invoice on taxable items should be provided to this office for record.
- (ix) Sweet & palatable water only shall have to be used in construction work which is to be arranged by the contractor.
- (x) The Arbitration clause from the agreement stands deleted.
- (xi) The work must be carried out as per PWD/PHE specifications.
- (xii) The successful bidder shall furnish 5% performance security of contract value, in the shape of bank guarantee to procuring agency within the period of (14) Fourteen days of the receipt of Letter of acceptance of work order.

3. In consideration of the payments to be made by the Procuring Agency to the Contractor as hereinafter mentioned, the Contractor hereby covenants with the Procuring Agency to execute and complete the Works and remedy defects therein in conformity and in all respects within the provisions of the Contract.

4. The Procuring Agency hereby covenants to pay the Contractor, in consideration of the execution and completion of the Works as per provisions of the Contract, the Contract Price or such other sum as may become payable

Moham M. M.  
Modern Engineering Works



under the provisions of the Contract at the times and in the manner prescribed by the Contract.

5. Now withstanding anything contained to the contrary or conflict with the provision of this agreement in any of the documents mentioned in clause 1, above the provision of this agreement shall prevail and the documents mentioned above, shall be deemed to have been amended to the extent of inconsistency found therein, by the provision of this agreement, in case of inconsistency between any of the document referred to herein, the later documents shall prevail and the tender documents shall be constructed to have been amended to that extend.

6. this contract shall not be transferable or assignable in whole or part of any of parties hereto, provided that the owner may assign his rights and obligations in whole or in part or any other company which shall be entirely owned Company belonging to the same group of the companies as the owner, in such as event touch other company shall be either to act to as owner under this contract.

IN WITNESS WHEREOF the parties hereto have caused this Contract Agreement to be executed on the day, month and year first before written in accordance with their respective Laws.

Mohar Mal

**MODERN ENGINEERING WORK  
GOVERNMENT CONTRACTOR**

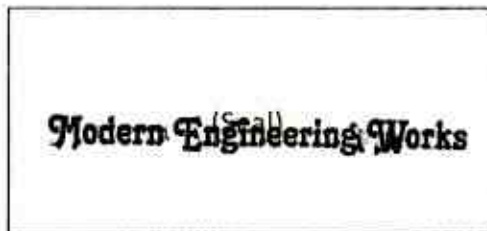

Nazar Muhammad Bozdar

**NAZAR MUHAMMAD BOZDAR  
DIRECTOR (F&A)  
PDMA, SINDH**

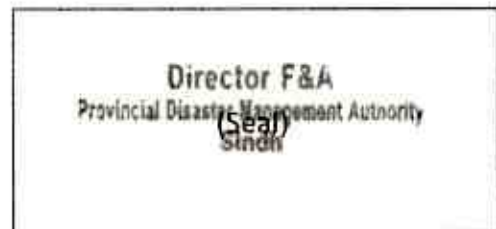

Signed, Sealed and Delivered in the presence of:

Witness:

Signature

Name

Title:

CNIC:

Naveed Mal

Naveed Mal

\_\_\_\_\_

42501-3743090-7

Witness:

Signature

Name

Title:

CNIC:

Asif Kumar Senoo

Asif Kumar Senoo

Assistant Director

4220179425515



**OFFICE OF THE PROVINCIAL DISASTER MANAGEMENT AUTHORITY KARACHI**

(4)

Tender Form issued to M/S Nevatmal Govt Contractor Government Contractor.

Charge to Rs:-3000/= Vide D.R No: 03447052 Dated the:- 08-01-2015

  
DIRECTOR FINANCE (PDMA)  
GOVERNMENT OF SINDH KARACHI

**NAME OF WORK:-** PROVISION AND INSTALATION OF HAND DEEP PUMP AT KOHISTAN AREAS IN DISTRICT JAMSHORO, KOTRI, MANJHAND, & SEWAN UNION COUNCIL SINDH UNIVERSITY, MARHO, JABAL, AMRI MANZORABAD SUN, LAKHA AND JHANGARA (DEEP HAND PUMP 79-NOS)

I/We hereby tender for execution of the works of Government of Sindh herein before/after referred to as Government of the work specification in the written memorandum with time specification in each memorandum at:-

i.  Civil Work

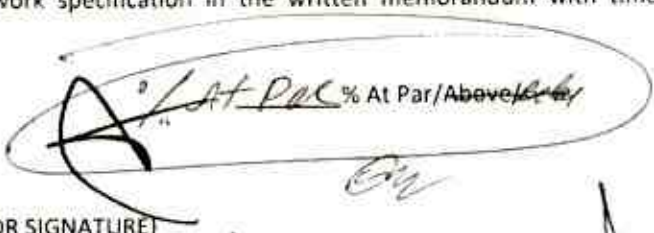
  
(CONTRACTOR SIGNATURE)

  
DIRECTOR FINANCE (PDMA)  
GOVERNMENT OF SINDH KARACHI

The estimate carried out & according to all respect with the specification design/drawing & instruction in writing referred to rule-1 here of the clause-12 of the annexed condition of the contract & agreement that when material for the work are provided by the Govt: such material & rate to paid for then shall be as provided in Schedule 'B' here to:-

**GENERAL DESCRIPTION**

i.	Estimated Cost	Rs:-14.518-Million
ii.	Earnest Money 2%	Rs:-0.290-Million
iii.	S/Deposit in/c: E/Money 10%	Rs:-1.451-Million
iv.	Income Tax will be deducted 7%	Rs:-1.016-Million
v.	Time of Completion of Work:-	Rs:-03-Months

I/We have offered the above rates after taking into consideration all the terms & conditions as per B-I printed tender & this form so as to completed the agreement, In case of Failure the Department will be at liberty to take action me /us.

BIDDING DACUMENTS/BOQ

Attached herewith

Call Deposit/Pay order bearing No: 0000033896 Dated:- 12/01/2015  
Amounting to Rs:- 290500/- Bank The Bank of Punjab Branch Karachi  
is enclosed herewith as desired on account of Security Deposit

  
(CONTRACTOR SIGNATURE)

## SCHEDULE "B"

Name of work:-

Provision and Installation of hand pump at Kohistan area in District Jamshoro Taluka Kori Manjhand & Sewan U/C Sindh university Morhojabal, Amri, Manzoorabad, Lakha & Jhangari (Deep Hand pump 79Nos)

- |                       |  |                 |              |         |                   |
|-----------------------|--|-----------------|--------------|---------|-------------------|
| 1.                    | Boring of Tube Well in water bearing soil from ground level upto 100ft depth i/c sinking and with drawing and casing pipes (PHSINO. 1P/36).  | 7900Rft         | @ Rs.414/=   | Per Rft | Rs.32,70,600/-    |
| 2.                    | Boring of Tube Well in water bearing soil from depth 101' to 200' below ground level i/c sinking and with drawing and casing pipes (PHSINO. 2P/42).  | 6320Rft         | @ Rs.516/=   | Per Rft | Rs.32,61,120/-    |
| 3.                    | Supplying and Installing PVC Blind pipe "C" Class approved designed quality and make i/c necessary sockets etc complete (PHSINO. 11P/14 & PHSMNo.16P/111).   | 7900Rft         | @ Rs.212.10  | Per Rft | Rs.16,755,900/-   |
| 4.                    | Supplying and Installing PVC Strainer Pipe "B" Class of approved design quality including necessary sockets etc complete. (PHSINO. 9b P/43).   | 6320 Rft        | @ Rs.242.95  | Per Rft | Rs.15,35,444/-    |
| 5.                    | Shrouding with Graded Bajri (3/8" to 1/8" or 9 to 3mm) in between bore and blind pipe for the following diameter or strainer (PHSINO. 13P/35).   | 7110Rft         | @ Rs.49.00   | Per Rft | Rs.-348,390/-     |
| 6.                    | Construction of CC Platform inside 4' x 4' with 1/2" Thick Wall and CC drain in length 10' (Based on scheduled rate).  | 79-Nos          | @ Rs.-6691/= | Each    | Rs.-528,589/-     |
| <b>Total Rupees:-</b> |  |                 |              |         | <b>10619733/-</b> |
| 7.                    | Supplying installing Rising with one end socket factor Standard DS 3505 Pipe material UPVC class "E" pipe pressure 15 Bars wall thickness 4.7 mm dia 63 mm (Rate approved)   | 11850Rft @ Rs.- | 67           | Per Rft | Rs.- 793950/-     |
| 8.                    | Supplying, Installing and Testing Deep hand pump pipe machine suitable for Kohistan area superior quality make as per site requirement i/c including all required accessories, i.e Labor Charges for levering the hand pump. | 79-Nos          | @ Rs.-24500  | Each    | Rs.-1935500/-     |

### TERMS AND CONDITIONS

1. Arbitration clause stands deleted from the agreement.
2. Any typographical errors in the schedule "B" are subject to correction with the reference to the schedule of rates General item 2012 in force -10-2012 as approved by the standing rates Committee Sindh, Karachi.
3. Water shall be arranged by the contractor at site of work without any extra payment.
4. No premium shall be paid on non-Schedule items.
5. No Cartage or any item of material either supplied by the Department or arranged by the Contractor shall be paid.
6. Contractor has to bring sample of the material and handed to the Engineer in charged free of cost.
7. All buildings debris & surplus stuff not req. for use construction shall be removed from the site and suitable disposed off by the contractor for which no extra cartages shall be paid.
8. This work will be carried out as per PWD Specifications.

CIVIL ENGINEER (PDMA)

DIRECTOR FINANCE (PDMA)

Cost Rs: 13349183/-  
Sd/- 13.3.17-Miller



PLAN AND SECTION OF PLATE FORM FOR HAND PUMP

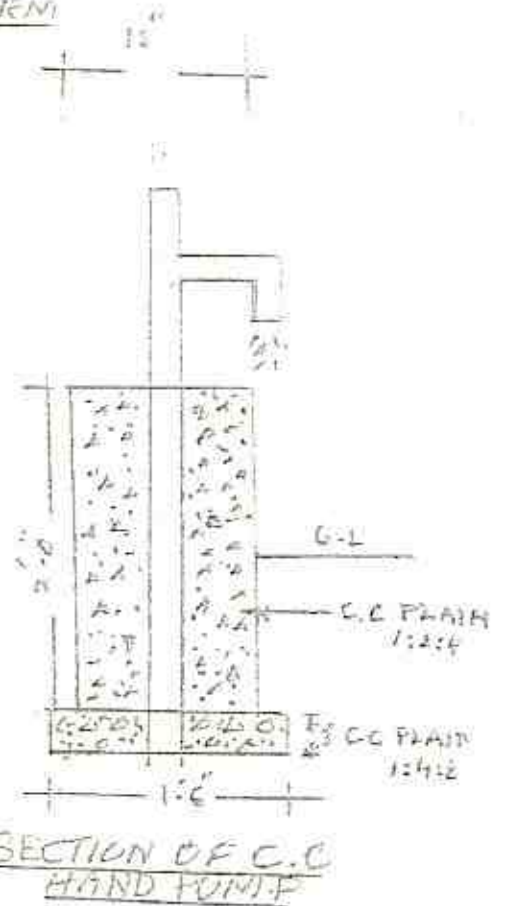
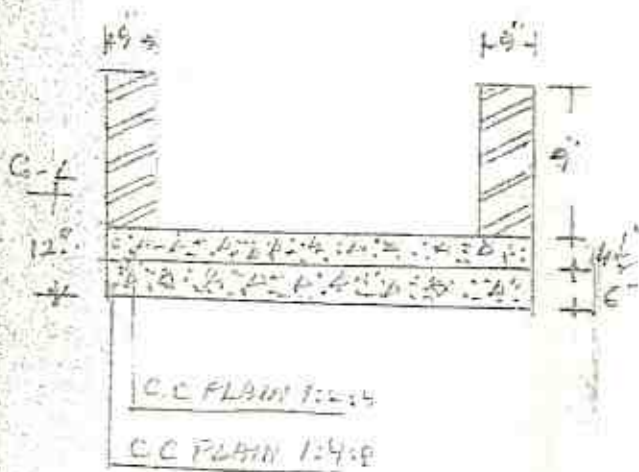

SECTION OF PLAT FORM.

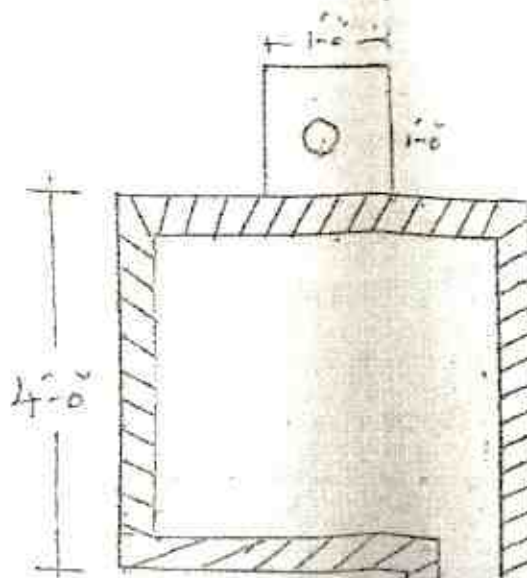

*[Handwritten signature]*

5

DEEP HAND PUMP  
KOHISTAN AREA OF THATTA DISTRICT

Steel  
plate  
6" x 6"

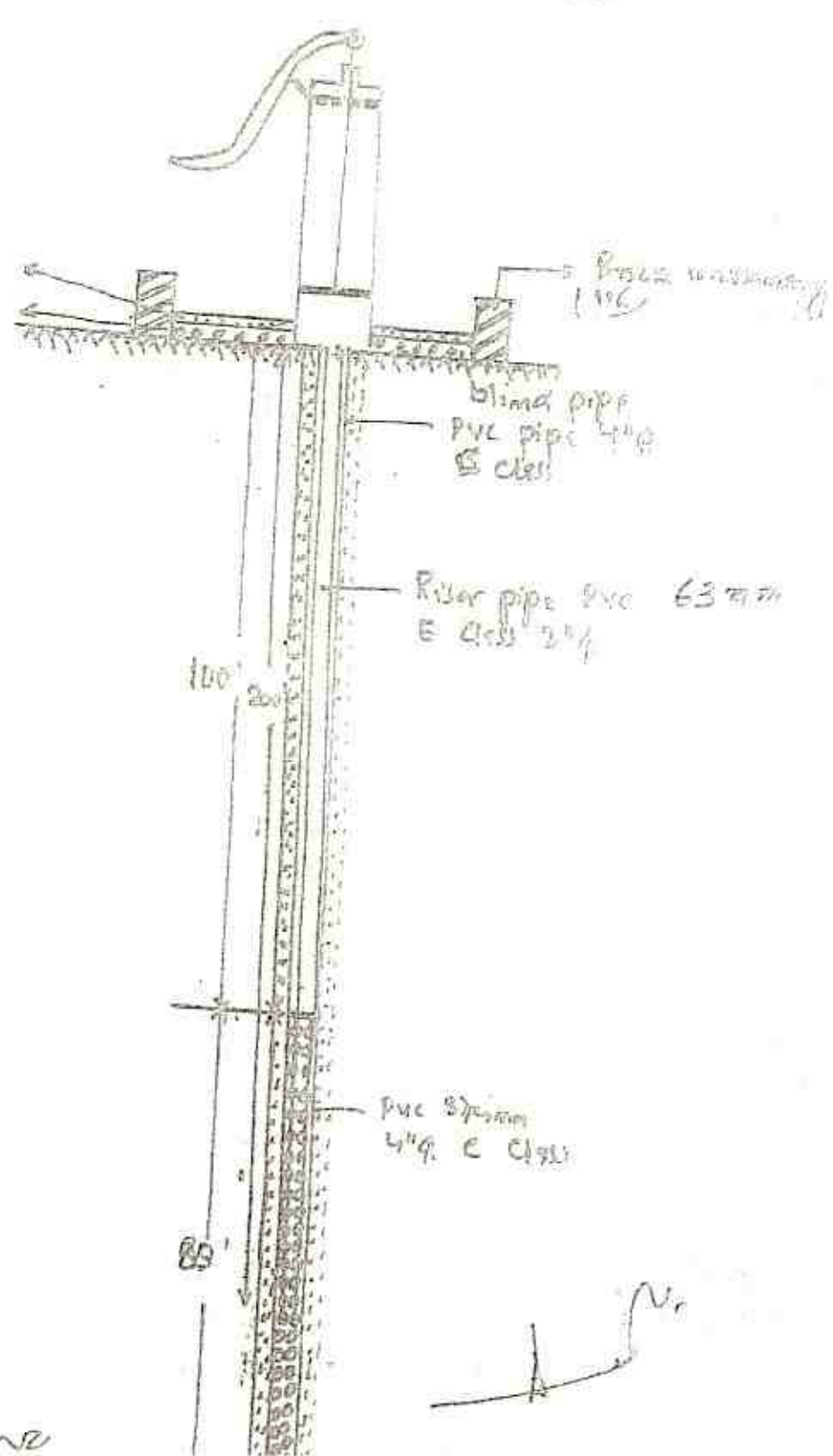

*[Signature]*





SIKANDAR IMRAN STAMP VENDOR  
 Licence No. 88, Seat No. 19, City Court Karachi.  
 S.No. ' 29697 DATE .....  
 ISSUED TO WITH ADDRESS .....  
 THROUGH WITH ADDRESS M.B. NAWAT MAL  
 PURPOSE .....  
 WITNESSES ..... (WITNESSED)  
 STAMP VENDOR'S SIGNATURE [Signature]

16 FEB 2015

OFFICE SUPERINTENDENT  
 City Court  
 Karachi  
 3-3-15  
 03 MAR 2015

**FORM OF CONTRACT AGREEMENT  
 SUM OF RS.13.349-MILLION**

THIS CONTRACT AGREEMENT (hereinafter called the -Agreement) made on the 23rd day of February, 2015 between Provincial Disaster Management Authority Rehabilitation Department Governments of Sindh Karachi

And

M/S Nevat Mal Government Contractor, Office at Top Ands Store, Bolani Muhalla jamote Bara, Ibrahim Hyderi Karachi (hereinafter called the Contractor) of the other part

[Signature]

WHEREAS, the Provincial Disaster Management Authority, lying its office in Bungalow No. 40, Street No.24 Khayaban-e- Mujahid DHA Phase V Karachi, is desirous certain work" Viz PROVISION AND INSTALLATION OF DEEP HAND PUMPS IN KOHISTAN AREA IN DISTRICT JAMSHORO , KOTRI ,MANJHAND & SEWAN UNION COUNCIL SINDH UNIVERSITY MOHRO JABAL AMRI MANZORABAD SUN LAKHA AND JHANGARA (DEEP HAND PUMPS 79-NOS Should be executed & completed by the contractor and has accepted a bid, by the contractor for the execution and completion of the work and the remedying of any defects therein.

[Signature]  
**M/S NEVAT MAL**  
 Govt Contractor  
 Proprietor

NOW this Agreement witnesses as follows:

1. In this Agreement words and expressions shall have the same meanings as are respectively assigned to them in the Conditions of Contract hereinafter referred to.

2. The following documents after incorporating addenda, ( if any) except those parts relating to Instructions to Bidders, shall be deemed to form and be read and construed as an integrated part of this Agreement, viz:

- (a) The Letter of Acceptance; ( Annex-I)
- (b) The completed Form of Bid along with Schedules to Bid; (Annex-II)
- (c) Conditions of Contract & Contract Data ;( Annex-III)
- (d) The priced Schedule of Prices/Bill of quantities (BOQ); (Annex-IV)
- (e) The Specifications; (Annex-V) and
- (f) The Drawings (Annex-VI)
- (g) General Condition

- (i) In case of any variation in provisions of Schedule-B - as per accepted tender and technically sanction detailed working estimate, the execution of work shall be regulated in accordance with the provisions as per technically sanctioned working estimate.
- (ii) No Premium shall be allowed on Non-Schedule Items.
- (iii) The payment is not made to the firm, if the water does not comes after boring.
- (iv) No separate payment for carriage of material will be allowed.
- (v) All Material required in connection of the subjected work shall be procured and brought at site by the Contractor at his own cost.
- (vi) No Payment of extra items shall be made unless written order is given by the Undersigned for execution of the extra items and approved by the competent authority.
- (vii) Income tax shall be deducted from the bills on the above values of work done and paid for as per latest order of competent authority in this regard.
- (viii) The Sales tax invoice on taxable items should be provided to this office for record.
- (ix) Sweet & palatable water only shall have to be used in construction work which is to be arranged by the contractor.
- (x) The Arbitration clause from the agreement stands deleted.
- (xi) The work must be carried out as per PWD/PHE specifications.
- (xii) The successful bidder shall furnish 5% performance security of contract value, in the shape of bank guarantee to procuring agency within the period of (14) Fourteen days of the receipt of letter of acceptance of work order.

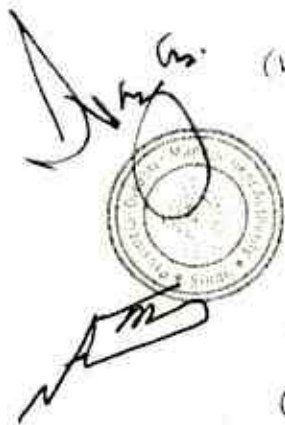

S. S. V. S. S.  
Govt. Engineer  
Proprietor

3. In consideration of the payments to be made by the Procuring Agency to the Contractor as hereinafter mentioned, the Contractor hereby covenants with the Procuring Agency to execute and complete the Works and remedy defects therein in conformity and in all respects within the provisions of the Contract.

4. The Procuring Agency hereby covenants to pay the Contractor, in consideration of the execution and completion of the Works as per provisions of the Contract, the Contract Price or such other sum as may become payable

under the provisions of the Contract at the times and in the manner prescribed by the Contract.

5. Now withstanding anything contained to the contrary or conflict with the provision of this agreement in any of the documents mentioned in clause 1, above the provision of this agreement shall prevail and the documents mentioned above, Shall be deemed to have been amended to the extent of inconsistency found therein, by the provision of this agreement, in case of inconsistency between any of the document referred to herein, the Later documents shall prevail and the tender documents shall be constructed to have been amended to that extend.

6. this contract shall not be transferable or assignable in whole or part of any of parties hereto, provided that the owner may assign his rights and obligations in whole or in part or any other company which shall be entirely owned Company belonging to the same group of the companies as the owner, in such as event touch other company shall be either to act to as owner under this contract .

IN WITNESS WHEREOF the parties hereto have caused this Contract Agreement to be executed on the day, month and year first before written in accordance with their respective Laws.



NEVAT MA

GOVERNMENT CONTRACTOR



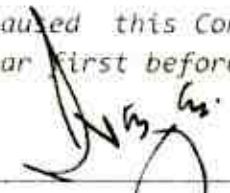

NAZAR MUHAMMAD BOZDAR  
DIRECTOR (F&A)  
PDMA, SINDH



Signed, Sealed and Delivered in the presence of:

Witness:

Signature 

Name Delip Kumar

Title: \_\_\_\_\_

CNIC: 42301-1197903-1

Witness:

Signature 

Name Ajay Kumar Senani

Title: Assistant Director

CNIC: 42201-7942551-5



**OFFICE OF THE PROVINCIAL DISASTER MANAGEMENT AUTHORITY KARACHI**

(3)

Tender Form issued to M/S: B.S. Traders Engineering Services Government Contractor.

Charge to Rs: 3000/= Vide D.R No: 03447048 Dated the: 08-01-2015

  
DIRECTOR FINANCE (PDMA)  
GOVERNMENT OF SINDH KARACHI

**NAME OF WORK:-** PROVISION AND INSTALATION OF HAND DEEP PUMP AT KOHISTAN AREAS IN DISTRICT JAMSHORO TALUKA BULA KHAN UNION COUNCIL SARI, THANO ARAB (DEEP HAND PUMP 120-NOS)

I/We hereby tender for execution of the works of Government of Sindh herein before/after referred to as Government of the work specification in the written memorandum with time specification in each memorandum at:-

I. Civil Work At Par % At Par/Above/Below  
  
(CONTRACTOR SIGNATURE)

  
DIRECTOR FINANCE (PDMA)  
GOVERNMENT OF SINDH KARACHI

The estimate carried out & according to all respect with the specification design/drawing & instruction in writing referred to rule-1 here of the clause-12 of the annexed condition of the contract & agreement that when material for the work are provided by the Govt: such material & rate to paid for then shall be as provided in Schedule 'B' here to:-

**GENERAL DESCRIPTION**

i.	Estimated Cost	Rs.-21.033-Million
ii.	Earnest Money 2%	Rs.-0.420-Million
iii.	S/Deposit in/c: E/Money 10%	Rs.-2.103-Million
iv.	Income Tax will be deducted 7%	Rs.-1.472-Million
v.	Time of Completion of Work:-	Rs.-03-Months

I/We have offered the above rates after taking into consideration all the terms & conditions as per B-I printed tender & this form so as to completed the agreement, In case of Failure the Department will be at liberty to take action me /us.

BIDDING DOCUMENTS/BOQ Attached herewith

Call Deposit/Pay order bearing No: 0049681 Dated: 12/01/2015  
Amounting to Rs: 480000/- Bank Sindh Bank Branch Karachi  
Is enclosed herewith as desired on account of Security Deposit

**B.S Traders & Engineering Services**  
  
(CONTRACTOR SIGNATURE)

## BILL OF QUANTITIES

**Name of Work:** Provision and Installation of Hand Pump at Kohistan area in District Jamshoro Taluka Tando Bola Khan Union Council Sari and Arab Khan ( Deep Hand Pump 120 Nos).

S.NOS	DESCRIPTION	QUANTITY	RATE	UNIT	AMOUNT
1	Name of Work: Provision and Installation of Hand Pump at Kohistan area in District Jamshoro Taluka Tando Bola Khan Union Council Sari and arab Khan ( Deep Hand Pump 120 Nos).	12000-Rft	Rs.-414/=	P-Rft	Rs.-49,68,000/=
2	Boring of Tube Well in water bearing soil from depth 101' to 200' below ground level i/c sinking and with drawing and casing pipes (PHSINo. 2P/42).	9600-Rft	Rs.-516/=	P-Rft	Rs.-49,53,600/=
3	Supplying and Installing PVC Blind pipe "C" Class approved designed quality and makes i/c necessary sockets etc complete (PHSINo. 11P/14 & PHSMNo. 16P/111).	12000-Rft	Rs.-212/10	P-Rft	Rs.-25,45,200/=
4	Supplying and Installing PVC Strainer Pipe "B" Class of approved design quality including necessary sockets etc complete (PHSINo. P43).	9600-Rft	Rs.-242/95	P-Rft	Rs.-23,32,320/=
5	Shrouding with Graded Bajri (3/8" to 1/8" or 9 to 3mm) in between bore and blind pipe for the following diameter or strainer (PHSINo. 13P/35).	10800-Rft	Rs.-49/46	P-Rft	Rs.- 529,200/=
6	Construction of CC Platform inside 4' x 4' with 1/2" Thick Wall and CC drain in length 10' (Based on scheduled rate).	120-Nos	Rs.-6691/=	Each	Rs.- 802,920/=
Total Schedule Items					Rs.-1,61,31,240/=
7	<b>NON-SCHEDULE ITEMS</b> Supplying installing Rising with one end socket factor Standar DS 3505 Pipe material UPVC class 'E' pipe pressure 15 Bars wall thickness 4.7 mm dia 63 mm (Rate approved)	18000-Rft	Rs -	P-Rft	1188000/=
8	Supplying, Installing and Testing Deep hand pump pipe machine suitable for Kohistan area superior quality make as per site requirement i.e including all required accessories, i.e Labor Charges for lowering the hand pump	120-Nos	24500/=	Each	2940000/=
Net Amount Rs:-					Rs. 20,259,240/-

### TERMS AND CONDITIONS

1. Arbitration clause stands deleted from the agreement.
2. Any typographical errors in the schedule "B" are subject to correction with the reference to the schedule of rates General item 2012 in force -10-2012 as approved by the standing rates Committee Sindh, Karachi.
3. Water shall be arranged by the contractor at site of work without any extra payment.
4. No premium shall be paid on non-Schedule items.
5. No Cartage or any item of material either supplied by the Department or arranged by the Contractor shall be paid.
6. Contractor has to bring sample of the material and handed to the Engineer in charged free of cost.
7. All buildings debris& surplus stuff not req. for use construction shall be removed from the site and suitable disposed off by the contractor for which no extra cartages shall be paid.
8. This work will be carried out as per PWD Specifications.

CIVIL ENGINEER (PDMA)

DIRECTOR FINANCE (PDMA)

PLAN AND SECTION OF PLATE FORM FOR HAND PUMP

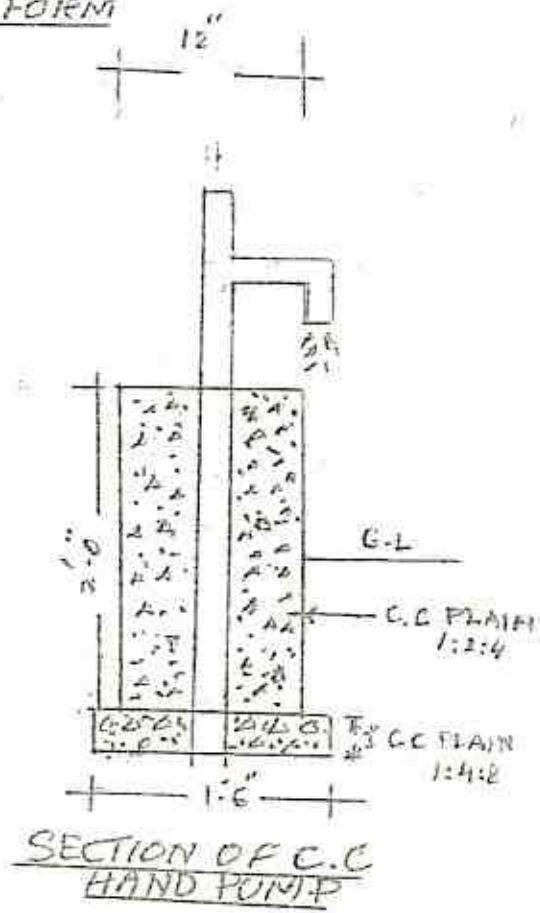
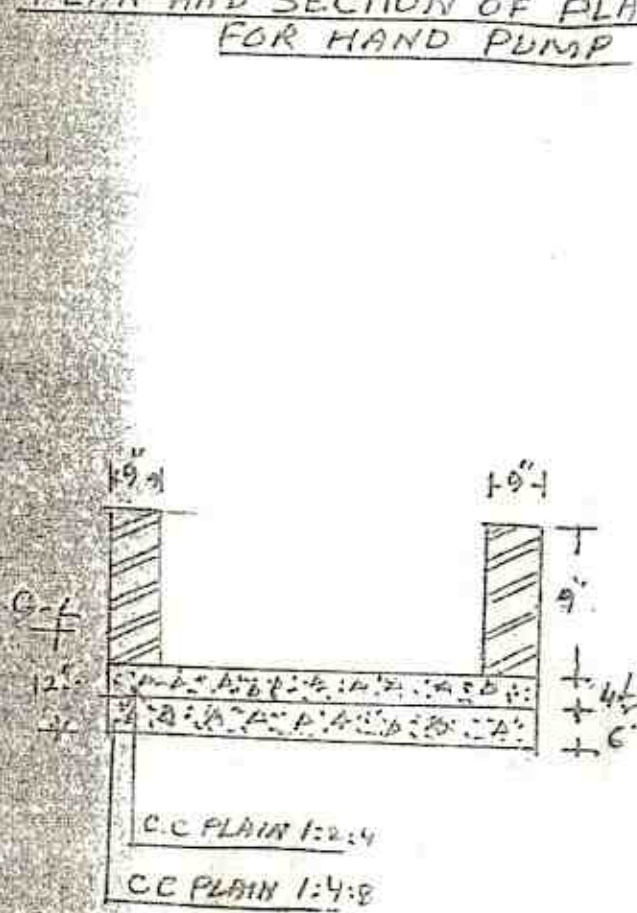

SECTION OF PLAT FORM.

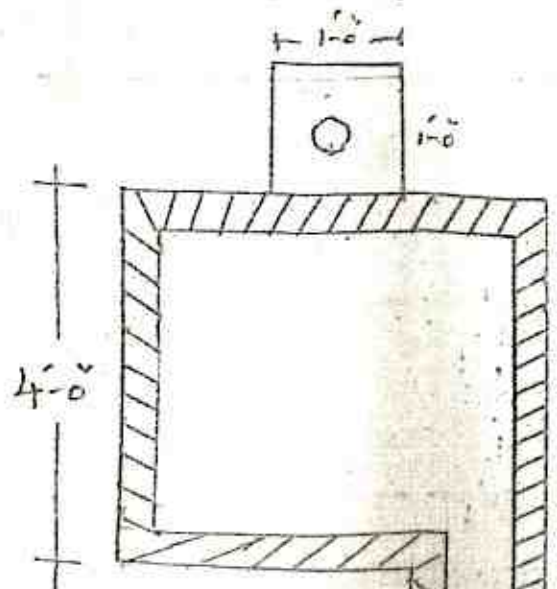

*[Handwritten signature]*



5

DEEP HAND PUMP  
KOHISTAN AREA OF THAKKA DISTRICT

Blind  
ply 1/2"  
ply  
1/8" 6"

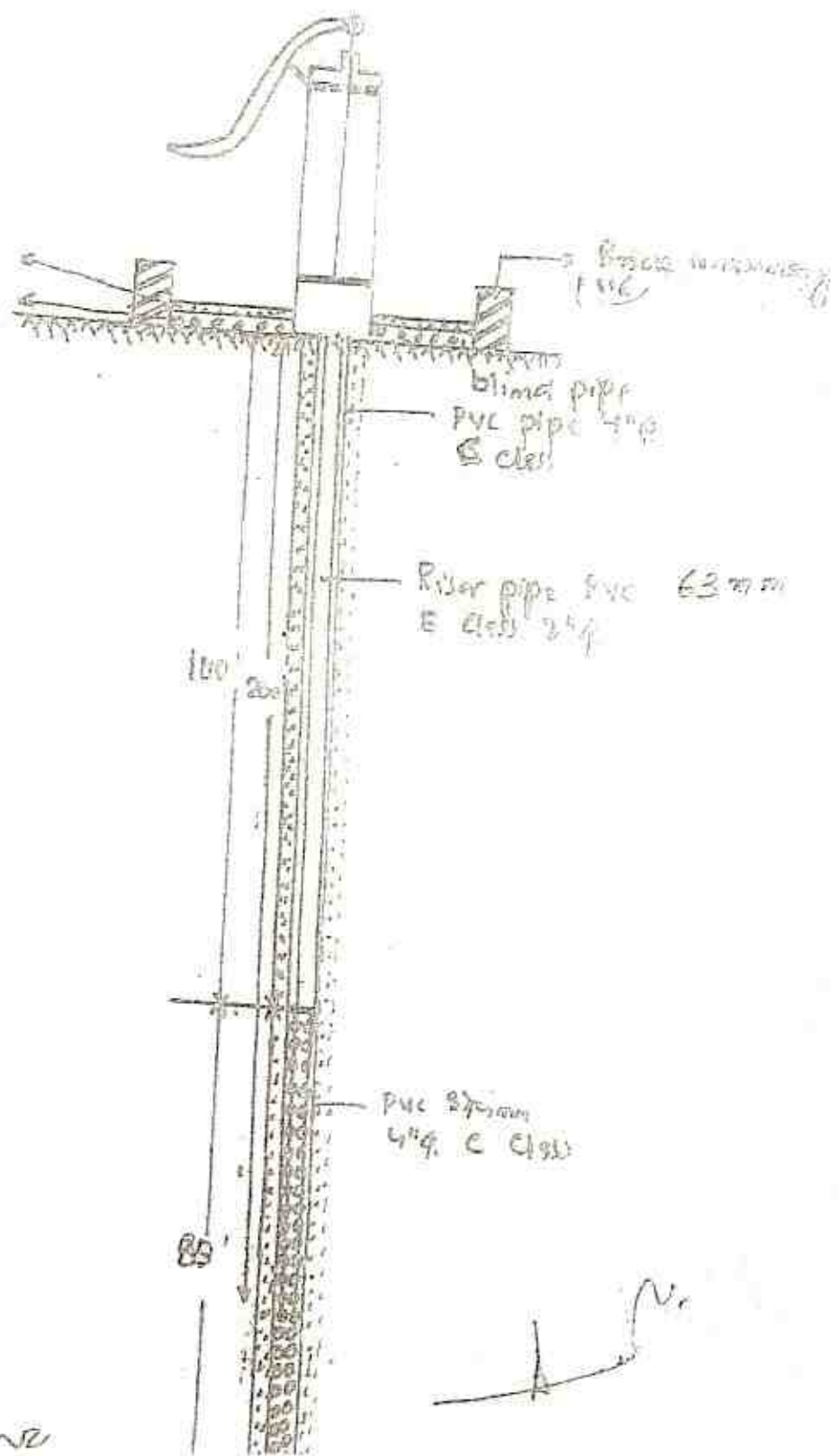



200 Rupees



SIKANDAR IMRAN STAMP VENDOR  
License No. 505 for Sindh Govt Karachi  
S.N. 29636  
ISSUED TO: M/S B.S. Traders  
THROUGH: M/S B.S. Traders  
FOR: [unclear]  
VALUE: [unclear]  
STAMP VENDOR'S SIGNATURE: [unclear]

16 FEB 2015

*[Handwritten signature]*  
3-3-15  
Karachi

03 MAR 2015

03 M

FORM OF CONTRACT AGREEMENT  
SUM OF RS.20.259-MILLION

THIS CONTRACT AGREEMENT (hereinafter called the -Agreement) made on the 23rd day of February, 2015 between Provincial Disaster Management Authority Rehabilitation Department Governments of Sindh Karachi

And

*[Signature]*  
**B.S Traders**  
Engineering Services

M/S B.S. Traders & Engineering Services Government Contractor, Office at House No:39 Rehman Town Jamnadas Colony Phase-II Mirpurkhas (hereinafter called the Contractor) of the other part



WHEREAS, the Provincial Disaster Management Authority, lying its office in Bungalow No. 40, Street No.24 Khayaban-e- Mujahid DHA Phase V Karachi, is desirous certain work" Viz PROVISION AND INSTALLATION OF DEEP HAND PUMPS IN KOHISTAN AREA IN DISTRICT JAMSHORO TALUKA THANA BULA KHAN UNION COUNCIL SARI (DEEP HAND PUMPS 120-Nos) Should be executed & completed by the contractor and has accepted a bid, by the contractor for the execution and completion of the work and the remedying of any defects therein.

NOW this Agreement witnesses as follows:

- 1. In this Agreement words and expressions shall have the same meanings as are respectively assigned to them in the Conditions of Contract hereinafter referred to.

2. The following documents after incorporating addenda, (if any) except those parts relating to Instructions to Bidders, shall be deemed to form and be read and construed as an integrated part of this Agreement, viz:

- (a) The Letter of Acceptance; ( Annex-I)
  - (b) The completed Form of Bid along with Schedules to Bid; (Annex-II)
  - (c) Conditions of Contract & Contract Data ;( Annex-III)
  - (d) The priced Schedule of Prices/Bill of quantities (BOQ); (Annex-IV)
  - (e) The Specifications; (Annex-V) and
  - (f) The Drawings (Annex-VI)
  - (g) General Condition
    - (i) In case of any variation in provisions of Schedule-B - as per accepted tender and technically sanction detailed working estimate, the execution of work shall be regulated in accordance with the provisions as per technically sanctioned working estimate.
    - (ii) No Premium shall be allowed on Non-Schedule Items.
    - (iii) The payment is not made to the firm, if the water does not comes after boring.
    - (iv) No separate payment for carriage of material will be allowed.
    - (v) ALL Material required in connection of the subjected work shall be procured and brought at site by the Contractor at his own cost.
    - (vi) No Payment of extra items shall be made unless written order is given by the Undersigned for execution of the extra items and approved by the competent authority.
    - (vii) Income tax shall be deducted from the bills on the above values of work done and paid for as per latest order of competent authority in this regard.
    - (viii) The Sales tax invoice on taxable items should be provided to this office for record.
    - (ix) Sweet & palatable water only shall have to be used in construction work which is to be arranged by the contractor.
    - (x) The Arbitration clause from the agreement stands deleted.
    - (xi) The work must be carried out as per PWD/PHE specifications.
- The successful bidder shall furnish 5% performance security of contract value, in the shape of bank guarantee to procuring agency within the period of (14) Fourteen days of the receipt of Letter of acceptance of work order.

  
**B.S Traders & Engineering Services**

3. In consideration of the payments to be made by the Procuring Agency to the Contractor as hereinafter mentioned, the Contractor hereby covenants with the Procuring Agency to execute and complete the works and remedy defects therein in conformity and in all respects within the provisions of the Contract.

4. The Procuring Agency hereby covenants to pay the Contractor, in consideration of the execution and completion of the Works as per provisions of the Contract, the Contract Price or such other sum as may become payable under the provisions of the Contract at the times and in the manner prescribed by the Contract.

5. Now withstanding anything contained to the contrary or conflict with the provision of this agreement in any of the documents mentioned in clause 1, above the provision of this agreement shall prevail and the documents mentioned above, Shall be deemed to have been amended to the extent of inconsistency found therein, by the provision of this agreement, in case of inconsistency between any of the document referred to herein, the Later documents shall prevail and the tender documents shall be constructed to have been amended to that extend.

6. this contract shall not be transferable or assignable in whole or part of any of parties hereto, provided that the owner may assign his rights and obligations in whole or in part or any other company which shall be entirely owned Company belonging to the same group of the companies as the owner, in such as event touch other company shall be either to act to as owner under this contract.

IN WITNESS WHEREOF the parties hereto have caused this Contract Agreement to be executed on the day, month and year first before written in accordance with their respective laws.

  
\_\_\_\_\_

**B.S. TRADERS & ENGINEERING SERVICES**  
**GOVERNMENT CONTRACTOR**

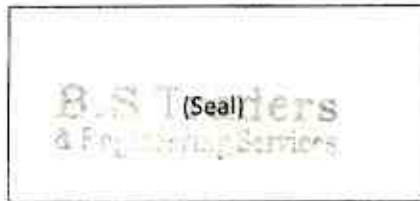

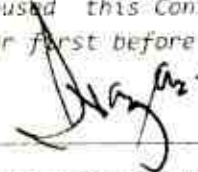
  
\_\_\_\_\_

**NAZAR MUHAMMAD BOZDAR**  
**DIRECTOR (F&A)**  
**PDMA, SINDH**

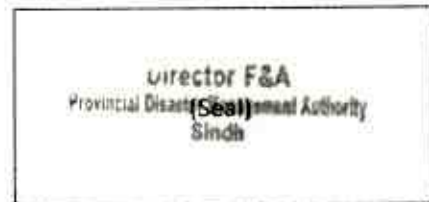

Signed, Sealed and Delivered in the presence of:

Witness:  
Signature   
Name Lekhraj  
Title: \_\_\_\_\_  
CNIC: 42501-3887896-1

Witness:  
Signature   
Name Asay Kumar Saman  
Title: Asistan Director  
CNIC: 42201-7992561-5



**OFFICE OF THE PROVINCIAL DISASTER MANAGEMENT AUTHORITY KARACHI**

(5)

Tender Form issued to M/S: B.S. Engineers & Contracting Services Government Contractor.

Charge to Rs:-3000/= Vide D.R No: 03447049 Dated the: 08-01- 2015

*[Signature]*  
DIRECTOR FINANCE (PDMA)  
GOVERNMENT OF SINDH KARACHI

NAME OF WORK:-

PROVISION AND INSTALATION OF HAND DEEP PUMP AT KOHISTAN AREAS IN DISTRICT THATTA TALUKA THATTA UNION COUNCIL JHAMPIR (DEEP HAND PUMP 174-NOS)

I/We hereby tender for execution of the works of Government of Sindh herein before/after referred to as Government of the work specification in the written memorandum with time specification in each memorandum at:-

i. *[Signature]*  
Civil Work

At Par % At Par/Above/Below

(CONTRACTOR SIGNATURE)

*[Signature]*  
DIRECTOR FINANCE (PDMA)  
GOVERNMENT OF SINDH KARACHI

The estimate carried out & according to all respect with the specification design/drawing & instruction in writing referred to rule-1 here of the clause-12 of the annexed condition of the contract & agreement that when material for the work are provided by the Govt: such material & rate to paid for then shall be as provided in Schedule 'B' here to:-

**GENERAL DESCRIPTION**

i.	Estimated Cost	Rs:- 30.080-Million
ii.	Earnest Money 2%	Rs:-0.601-Million
iii.	S/Deposit in/c: E/Money 10%	Rs:-3.008-Million
iv.	Income Tax will be deducted 7%	Rs:-2.105-Million
v.	Time of Completion of Work:-	Rs:-03-Months

I/We have offered the above rates after taking into consideration all the terms & conditions as per B-1 printed tender & this form so as to completed the agreement, In case of Failure the Department will be at liberty to take action me /us.

BIDDING DOCUMENTS/BOQ

Attached herewith

Call Deposit/Pay order bearing No: 0049679 Dated: 13/01/2015  
Amounting to Rs:- 690000/- Bank QAD Bank Branch Karachi  
Is enclosed herewith as desired on account of Security Deposit

*[Signature]*  
(CONTRACTOR SIGNATURE)

## SCHEDULE "B"

Name of work:- Provision and Installation of hand pump at Kohistan area in District Jamshoro Taluka U/C Jhampir (Deep Hand Pump 174-Nos)

- |                             |   |           |                |         |                  |
|-----------------------------|---|-----------|----------------|---------|------------------|
| 1.                          | Boring of Tube Well in water bearing soil from ground level upto 100ft depth i/c sinking and with drawing and casing pipes (PHSINo. 1P/36).   | 17400-Rft | @ Rs-414/=     | Per Rft | Rs-72,03,600/-   |
| 2.                          | Boring of Tube Well in water bearing soil from depth 101' to 200' below ground level i/c sinking and with drawing and casing pipes (PHSINo. 2P/42).   | 13920-Rft | @ Rs. 516/=    | Per Rft | Rs. 71,82,720/-  |
| 3.                          | Supplying and Installing PVC Blind pipe "C" Class approved designed quality and make i/c necessary sockets etc complete (PHSINo. 11P/14 & PHSM/No. 16P/111)   | 17400-Rft | @ Rs. 242/10   | Per Rft | Rs. 36,90,540/-  |
| 4.                          | Supplying and Installing PVC Strainer Pipe "B" Class of approved design quality including necessary sockets etc complete (PHSINo. 9b P/43).   | 3920-Rft  | @ Rs. 242/95   | Per Rft | Rs. -33,81,864/- |
| 5.                          | Shrouding with Graded Bajri (3/8" to 1/8" or 9 to 3mm) in between bore and blind pipe for the following diameter or strainer (PHSINo. 13P/35).  | 15660-Rft | @ Rs.-49/=     | Per Rft | Rs.-767,340/-    |
| 6.                          | Construction of CC Platform inside 4' x 4' with 1/2" Thick Wall and CC drain in length 10' (Based on scheduled rate).   | 174-Nos   | @ Rs.-6691/=   | Each    | Rs.-11,64,234/-  |
| Total Rupees:- <i>Jat L</i> |   |           |                |         | 23290298/-       |
| 7.                          | Supplying installing Rising with one end socket factor Standar DS 3505 Pipe material UPVC class 'E' pipe pressure 15 Bars wall thickness 4.7 mm dia 63 mm (Rate approved)   | 26100-Rft | @ Rs.- 66/1    | Per Rft | Rs.- 1722600/-   |
| 8.                          | Supplying, Installing and Testing Deep hand pump pipe machine suitable for Kohistan area superior quality make as per site requirement i.e including all required accessories, i. Labor Charges for levering the hand pump. | 174-Nos   | @ Rs.- 24500/- | Each    | Rs.- 4263000/-   |
|                             |   |           |                |         | 29375898/-       |

### TERMS AND CONDITIONS

1. Arbitration clause stands deleted from the agreement.
2. Any typographical errors in the schedule "B" are subject to correction with the reference to the schedule of rates General item 2012 in force -10-2012 as approved by the standing rates Committee Sindh, Karachi.
3. Water shall be arranged by the contractor at site of work without any extra payment.
4. No premium shall be paid on non-Schedule items.
5. No Cartage or any item of material either supplied by the Department or arranged by the Contractor shall be paid.
6. Contractor has to bring sample of the material and handed to the Engineer in charged free of cost.
7. All buildings debris & surplus stuff not req. for use construction shall be removed from the site and suitable disposed off by the contractor for which no extra cartages shall be paid.
8. This work will be carried out as per PWD Specifications.

*[Signature]*  
CIVIL ENGINEER (PDMA)

*[Signature]*  
DIRECTOR FINANCE (PDMA)

*Sept 29. 29.375-Million*

DEEP HAND PUMP  
KOHISTAN AREA OF THATTA DISTRICT

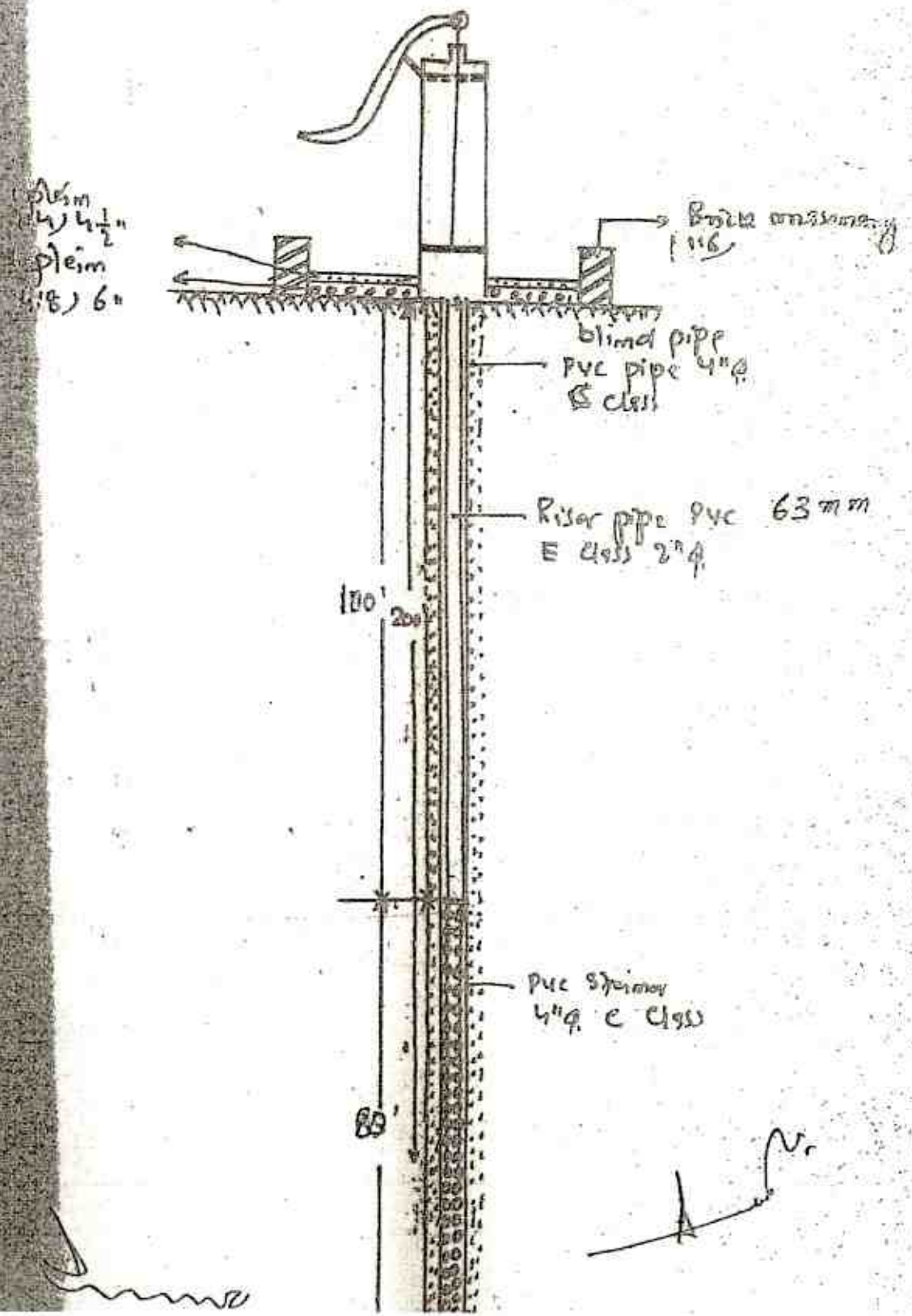

2

PLAN AND SECTION OF PLATE FORM FOR HAND PUMP

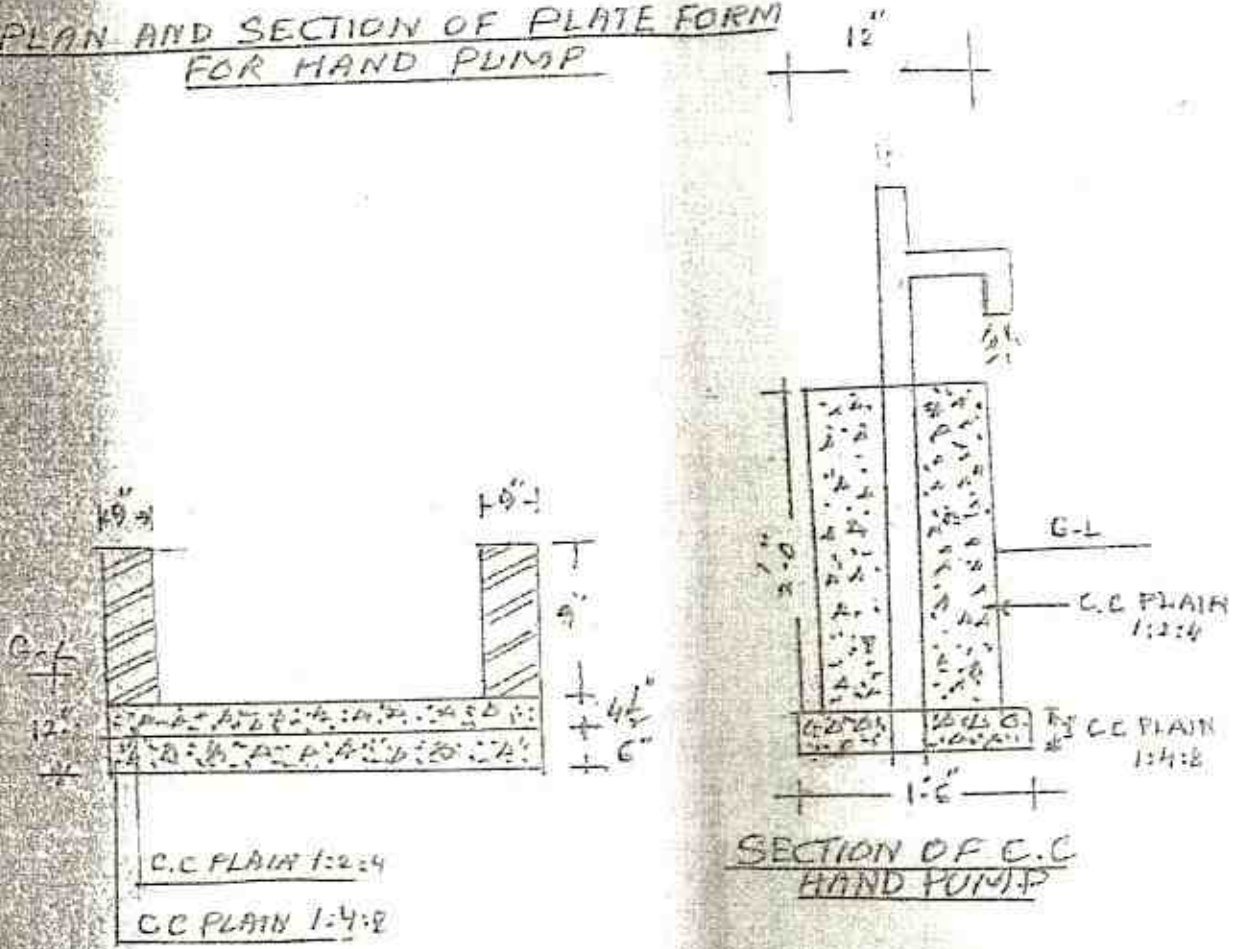

SECTION OF PLAT FORM.

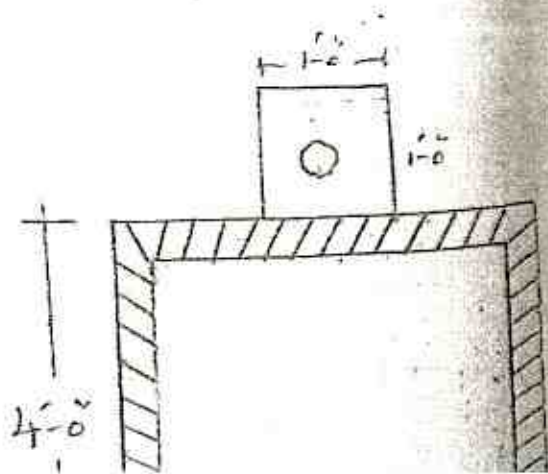

*[Handwritten signature]*





SIKANDAR IMRAN STAMP VENDOR  
Licence No. 88, Seat No. 19, City Court Karachi  
S.No. 29638 DATE  
M/S. B.S. Traders  
[Signature]

16 FEB 2015

OFFICE SUPERINTENDENT  
Stamp Office, City Court  
Karachi  
353215

03 MAR 2015

FORM OF CONTRACT AGREEMENT  
SUM OF RS.29.375-MILLION

THIS CONTRACT AGREEMENT (hereinafter called the -Agreement) made on the 23rd day of February, 2015 between Provincial Disaster Management Authority Rehabilitation Department Governments of Sindh Karachi

And



M/S B.S. Traders & Engineering Services Government Contractor, Office at House No:39 Rehman Town Jamnadas Colony Phase-II Mirpurkhas (hereinafter called the Contractor) of the other part

B.S Traders & Engineering Services

WHEREAS, the Provincial Disaster Management Authority, lying its office in Bungalow No. 40, Street No.24 Khayaban-e- Mujahid DHA Phase V Karachi, is desirous certain work" Viz PROVISION AND INSTALLATION OF DEEP HAND PUMPS IN KOHISTAN AREA IN DISTRICT AND TALUKA THATTA UNION COUNCIL JHAMPIR (DEEP HAND PUMPS 174-Nos) Should be executed & completed by the contractor and has accepted a bid, by the contractor for the execution and completion of the work and the remedying of any defects therein.

NOW this Agreement witnesses as follows:

1. In this Agreement words and expressions shall have the same meanings as are respectively assigned to them in the Conditions of Contract hereinafter referred to.



2. The following documents after incorporating addenda, (if any) except those parts relating to Instructions to Bidders, shall be deemed to form and be read and construed as an integrated part of this Agreement, viz:

- (a) The Letter of Acceptance; ( Annex-I)
- (b) The completed Form of Bid along with Schedules to Bid; (Annex-II)
- (c) Conditions of Contract & Contract Data ;( Annex-III)
- (d) The priced Schedule of Prices/Bill of quantities (BOQ); (Annex-IV)
- (e) The Specifications; (Annex-V) and
- (f) The Drawings (Annex-VI)
- (g) General Condition

- (i) In case of any variation in provisions of Schedule-B - as per accepted tender and technically sanction detailed working estimate, the execution of work shall be regulated in accordance with the provisions as per technically sanctioned working estimate.
- (ii) No Premium shall be allowed on Non-Schedule Items.
- (iii) The payment is not made to the firm, if the water does not come after boring.
- (iv) No separate payment for carriage of material will be allowed.
- (v) All Material required in connection of the subjected work shall be procured and brought at site by the Contractor at his own cost.
- (vi) No Payment of extra items shall be made unless written order is given by the Undersigned for execution of the extra items and approved by the competent authority.
- (vii) Income tax shall be deducted from the bills on the above values of work done and paid for as per latest order of competent authority in this regard.
- (viii) The Sales tax invoice on taxable items should be provided to this office for record.
- (ix) Sweet & palatable water only shall have to be used in construction work which is to be arranged by the contractor.
- (x) The Arbitration clause from the agreement stands deleted.
- (xi) The work must be carried out as per PWD/PHE specifications.
- (xii) The successful bidder shall furnish 5% performance security of contract value, in the shape of bank guarantee to procuring agency within the period of (14) Fourteen days of the receipt of Letter of acceptance of work order.

  
**B.S Traders  
& Engineering Service**

3. In consideration of the payments to be made by the Procuring Agency to the Contractor as hereinafter mentioned, the Contractor hereby covenants with the Procuring Agency to execute and complete the Works and remedy defects therein in conformity and in all respects within the provisions of the Contract.

4. The Procuring Agency hereby covenants to pay the Contractor, in consideration of the execution and completion of the Works as per provision of the Contract, the Contract Price or such other sum as may become payable

under the provisions of the Contract at the times and in the manner prescribed by the Contract.

5. Now withstanding anything contained to the contrary or conflict with the provision of this agreement in any of the documents mentioned in clause 1, above the provision of this agreement shall prevail and the documents mentioned above, Shall be deemed to have been amended to the extent of inconsistency found therein, by the provision of this agreement, in case of inconsistency between any of the document referred to herein, the Later documents shall prevail and the tender documents shall be constructed to have been amended to that extend.

6. this contract shall not be transferable or assignable in whole or part of any of parties hereto, provided that the owner may assign his rights and obligations in whole or in part or any other company which shall be entirely owned Company belonging to the same group of the companies as the owner, in such as event touch other company shall be either to act to as owner under this contract.

IN WITNESS WHEREOF the parties hereto have caused this Contract Agreement to be executed on the day, month and year first before written in accordance with their respective Laws.



**B.S. TRADERS & ENGINEERING SERVICES**  
**GOVERNMENT CONTRACTOR**

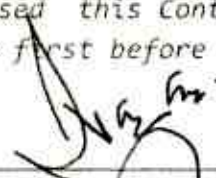

**NAZAR MUHAMMAD BOZDAR**  
**DIRECTOR (F&A)**  
**PDMA, SINDH**

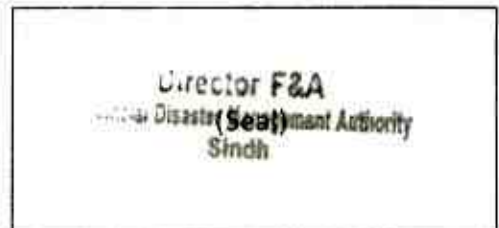

Signed, Sealed and Delivered in the presence of:

Witness:

Signature



Name

Lekhaaj

Title:

\_\_\_\_\_

CNIC:

42501-3887876-1

Witness:

Signature



Name

Asad Asay / Sumar

Title:

Assistant Director

CNIC:

42201-7442661-5



**OFFICE OF THE PROVINCIAL DISASTER MANAGEMENT AUTHORITY KARACHI**

81

Tender Form issued to M/S: Modern Engineering Works Government Contractor.

Charge to Rs:-3000/= Vide D.R No: 03447055 Dated the:- 05/01/2015

*Juz*  
DIRECTOR FINANCE (PDMA)  
GOVERNMENT OF SINDH KARACHI

**NAME OF WORK:-**

**PROVISION AND INSTALATION OF HAND DEEP PUMP AT KOHISTAN AREAS IN DISTRICT DADU TALUKA JOHI UNION COUNCIL PAT, GHULAM MUHAMMAD, DIG BELA, FAREEDABAD, CHOR 7 BURIRA (DEEP HAND PUMP 115-NOS)**

I/We hereby tender for execution of the works of Government of Sindh herein before/after referred to as Government of the work specification in the written memorandum with time specification in each memorandum at:-

I. Civil Work

0% At Par % At Par / Above / Below

**Modern Engineering Works**  
(CONTRACTOR SIGNATURE)

DIRECTOR FINANCE (PDMA)  
GOVERNMENT OF SINDH KARACHI

The estimate carried out & according to all respect with the specification design/drawing & instruction in writing referred to rule-1 here of the clause-12 of the annexed condition of the contract & agreement that when material for the work are provided by the Govt: such material & rate to paid for then shall be as provided in Schedule 'B' here to:-

**GENERAL DESCRIPTION**

i.	Estimated Cost	Rs:-20.536-Million
ii.	Earnest Money 2%	Rs:-0.410-Million
iii.	S/Deposit in/c: E/Money 10%	Rs:-2.056-Million
iv.	Income Tax will be deducted 7%	Rs:-1.437-Million
v.	Time of Completion of Work:-	Rs:-03-Months

I/We have offered the above rates after taking into consideration all the terms & conditions as per B-1 printed tender & this form so as to completed the agreement; In case of Failure the Department will be at liberty to take action me /us.

BIDDING DOCUMENTS/BOQ

Attached herewith

Call Deposit/Pay order bearing No: 0019461 Dated:- 13/01/2015  
Amounting to Rs:- 402500/- Bank ASKALI BANK Branch Karachi  
Is enclosed herewith as desired on account of Security Deposit

**Modern Engineering Works**  
(CONTRACTOR SIGNATURE)

## SCHEDULE "B"

Name of work:-

Provision and Installation of hand pump at Kohistan area in District Dadu Taluka Johi U/C Pot G Muhammad Dig Bala, Fareedabad, Choor and Burita (Deep Hand Pump 115 Nos)

- |                       |  |                           |         |                       |
|-----------------------|--|---------------------------|---------|-----------------------|
| 1.                    | Boring of Tube Well in water bearing soil from ground level up to 100ft depth i/c sinking and with drawing and casing pipes (PHSINO.1P/36).  | 11500-Rft @ Rs.444/=      | Per Rft | Rs 4761000/-          |
| 2.                    | Boring of Tube Well in water bearing soil from depth 101' to 200' below ground level i/c sinking and with drawing and casing pipes (PHSINO. 2P/42)   | 9200-Rft @ Rs.516/=       | Per Rft | Rs.4747200/-          |
| 3.                    | Supplying and Installing PVC Blind pipe "C" Class approved designed quality and make i/c necessary sockets etc complete (PHSINO.11P/14 & PHSMNo.16P/111)   | 11500-Rft @ Rs.212/10     | PerRft  | Rs.2439150/-          |
| 4.                    | Supplying and Installing PVC Strainer Pipe "C" Class of approved design quality including necessary sockets etc complete (PHSINO.9b P/43).   | 9200-Rft @ Rs.242/95      | PerRft  | Rs 22,35,140/-        |
| 5.                    | Shrouding with Graded Bajri (3/8" to 1/8" or 9 to 3mm) in between bore and blind pipe for the following diameter or strainer (PHSINO. 13P/35).   | 10350-Rft @ Rs.46/=       | Per Rft | Rs:-476,100/-         |
| 6.                    | Construction of CC Platform inside 4' x 4' with 1/2" Thick Wall and CC drain in length 10' (Based on scheduled rate).  | 115-Nos @ Rs.6621/=       | each    | Rs:-769,465/-         |
| <b>Total Rupees:-</b> |  |                           |         | <b>Rs:-15428055/2</b> |
| 7.                    | Supplying installing Rising with one end socket factor Standard DS 3505 Pipe material UPVC class 'E' pipe pressure 15 Bars wall thickness 4.7 mm dia 63 mm (Rate approved)   | 17250-Rft @ Rs. 66/=      | Per Rft | Rs:-1138500/-         |
| 8.                    | Supplying, Installing and Testing Deep hand pump pipe machine suitable for Kohistan area superior quality make as per site requirement i.e including all required accessories, i.e Labor Charges for levering the hand pump. | 115-Nos @ Rs.-24500/ Each | Each    | Rs. 28175002          |

### TERMS AND CONDITIONS

1. Arbitration clause stands deleted from the agreement.
2. Any typographical errors in the schedule "B" are subject to correction with the reference to the schedule of rates General item 2012 in force -10-2012 as approved by the standing rates Committee Sindh, Karachi.
3. Water shall be arranged by the contractor at site of work without any extra payment.
4. No premium shall be paid on non-Schedule items.
5. No Cartage or any item of material either supplied by the Department or arranged by the Contractor shall be paid.
6. Contractor has to bring sample of the material and handed to the Engineer in charged free of cost.
7. All buildings debris& surplus stuff not req. for use construction shall be removed from the site and suitable disposed off by the contractor for which no extra cartages shall be paid.
8. This work will be carried out as per PWD Specifications.

CIVIL ENGINEER (PDMA)

DIRECTOR FINANCE (PDMA)

Total Cost Rs. 19384055/-  
19.384 Million.

2

PLAN AND SECTION OF PLATE FORM FOR HAND PUMP

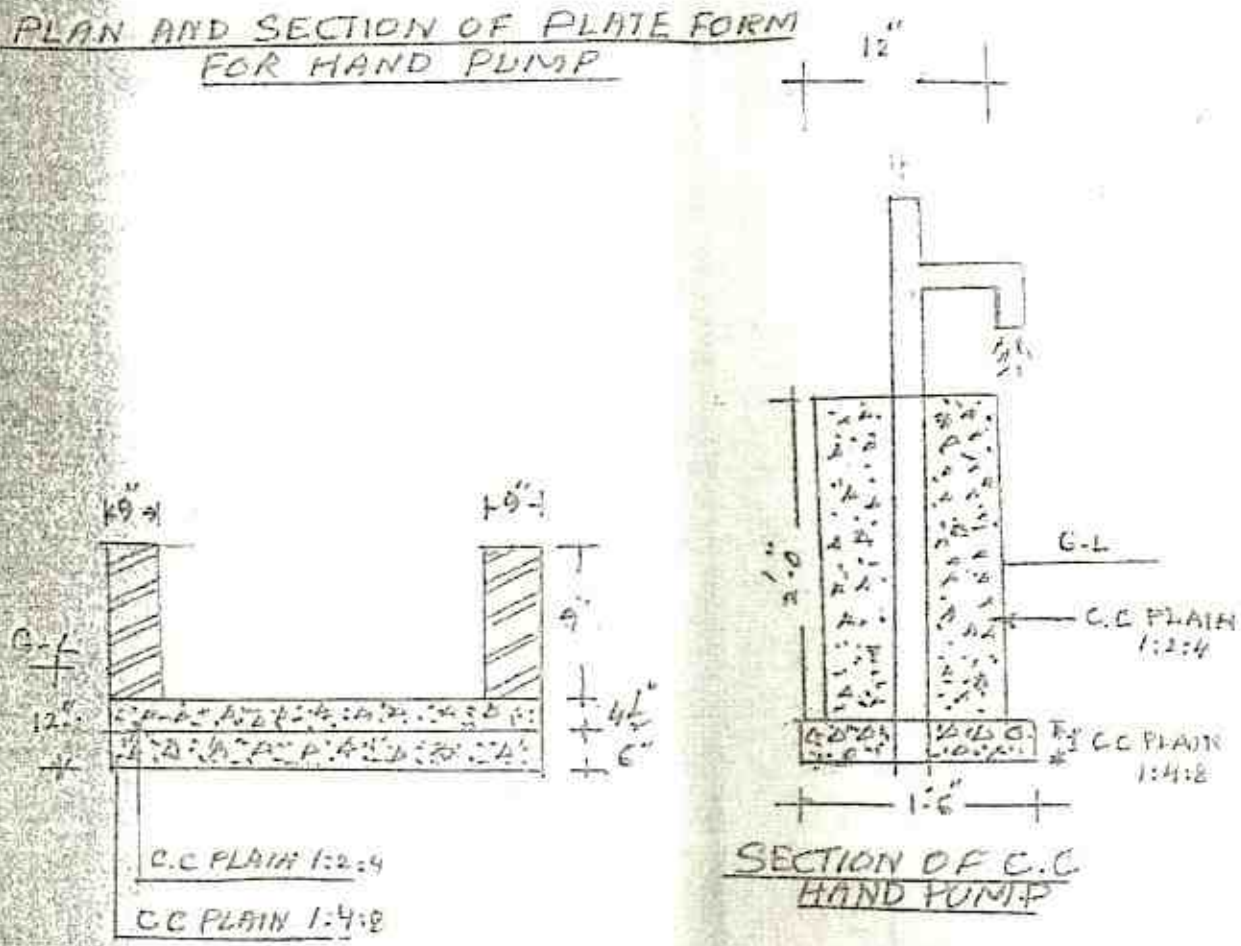

SECTION OF PLAT FORM.

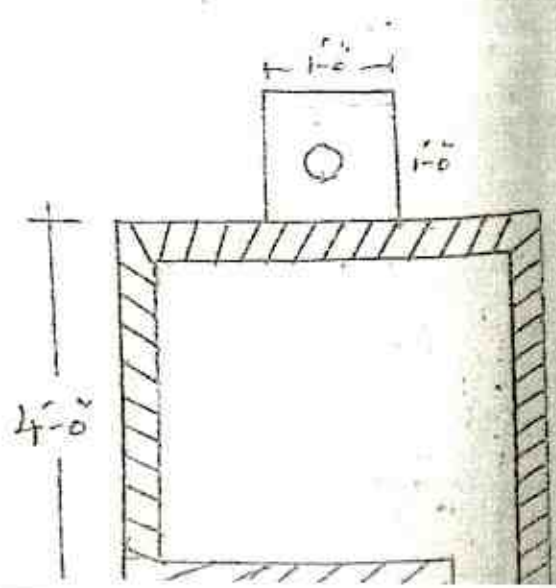

5

DEEP HAND PUMP  
KOHISTAN AREA OF THATTA DISTRICT

Blind  
ply 4" x 1/2"  
plaster  
4.8) 6"

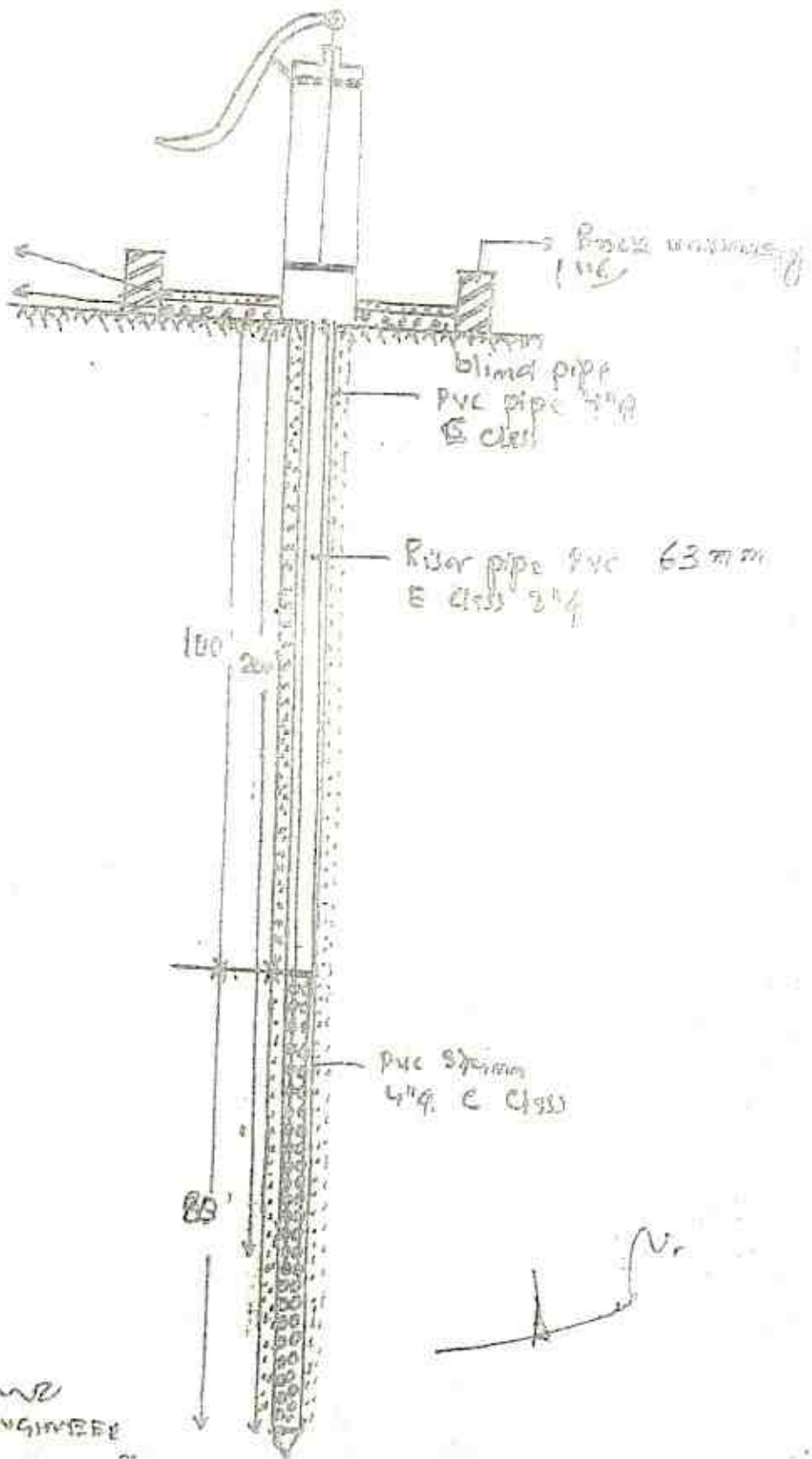

ASSISTANT ENGINEER

489982

58201

265



**SIKANDAR IMRAN STAMP VENDOR**

Licence No. 88, Seat No. 19, City Court Karachi.

S No **29695** DATE .....

ISSUED TO WITH ADDRESS .....

THROUGH WITH ADDRESS *M/S. MODERN ENGIN...*

PURPOSE .....

VALUATION .....

STAMP VENDOR'S SIGNATURE .....

16 FEB 2015

*Handwritten signature and date: 3-3-15*

OFFICE SUPERINTENDENT  
Stamp Office, City Court  
Karachi

03 MAR 2015

**FORM OF CONTRACT AGREEMENT  
SUM OF RS.19.384-MILLION**

THIS CONTRACT AGREEMENT (hereinafter called the -Agreement) made on the 23rd day of February, 2015 between Provincial Disaster Management Authority Rehabilitation Department Governments of Sindh Karachi

And

M/S Modern Engineering Work Government Contractor, Office -11 haji Wali Muhammad Arcade Centre Doctor Line Saddar Hyderabad (hereinafter called the Contractor) of the other part.

WHEREAS, the Provincial Disaster Management Authority, lying its office in Bungalow No. 40, Street No.24 Khayaban-e- Mujahid DHA Phase V Karachi, is desirous certain work" Viz PROVISION AND INSTALLATION OF DEEP HAND PUMPS IN KOHISTAN AREA IN DISTRICT DADU TALUKA JOHI UNION COUNCIL POT 6 MUHAMMAD DIG BELA FAREDABAD CHOOR AND BURIRA (DEEP HAND PUMPS 115-NOS Should be executed & completed by the contractor and has accepted a bid, by the contractor for the execution and completion of the work and the remedying of any defects therein.

NOW this Agreement witnesses as follows:

1. In this Agreement words and expressions, shall have the same meanings as are respectively assigned to them in the

*Handwritten signature*  
  
*Moham Md*  
**Modern Engineering Works**



Conditions of Contract hereinafter referred to.

2. The following documents after incorporating addenda, (if any) except those parts relating to Instructions to Bidders, shall be deemed to form and be read and construed as an integrated part of this Agreement, viz:

- (a) The Letter of Acceptance; (Annex-I)
- (b) The completed Form of Bid along with Schedules to Bid; (Annex-II)
- (c) Conditions of Contract & Contract Data ;( Annex-III)
- (d) The priced Schedule of Prices/Bill of quantities (BOQ); (Annex-IV)
- (e) The Specifications; (Annex-V) and
- (f) The Drawings (Annex-VI)
- (g) General Condition
  - (i) In case of any variation in provisions of Schedule-B - as per accepted tender and technically sanction detailed working estimate, the execution of work shall be regulated in accordance with the provisions as per technically sanctioned working estimate.
  - (ii) No Premium shall be allowed on Non-Schedule Items.
  - (iii) The payment is not made to the firm, if the water does not comes after boring.
  - (iv) No separate payment for carriage of material will be allowed.
  - (v) All Material required in connection of the subjected work shall be procured and brought at site by the Contractor at his own cost.
  - (vi) No Payment of extra items shall be made unless written order is given by the Undersigned for execution of the extra items and approved by the competent authority.
  - (vii) Income tax shall be deducted from the bills on the above values of work done and paid for as per latest order of competent authority in this regard.
  - (viii) The Sales tax invoice on taxable items should be provided to this office for record.
  - (ix) Sweet & palatable water only shall have to be used in construction work which is to be arranged by the contractor.
  - (x) The Arbitration clause from the agreement stands deleted.
  - (xi) The work must be carried out as per PWD/PHE specifications.
  - (xii) The successful bidder shall furnish 5% performance security of contract value, in the shape of bank guarantee to procuring agency within the period of (14) Fourteen days of the receipt of Letter of acceptance of work order.

3. In consideration of the payments to be made by the Procuring Agency to the Contractor as hereinafter mentioned, the Contractor hereby covenants with the Procuring Agency to execute and complete the Works and remedy defects therein in conformity and in all respects within the provisions of the contract.

4. The Procuring Agency hereby covenants to pay the Contractor, in consideration of the execution and completion of the Works as per provisions



Moham Md

Modern Engineering Works

of the Contract, the Contract Price or such other sum as may become payable under the provisions of the Contract at the times and in the manner prescribed by the Contract.

5. Now withstanding anything contained to the contrary or conflict with the provision of this agreement in any of the documents mentioned in clause 1, above the provision of this agreement shall prevail and the documents mentioned above, Shall be deemed to have been amended to the extent of inconsistency found therein, by the provision of this agreement, in case of in-consistency between any of the document referred to herein, the later documents shall prevail and the tender documents shall be constructed to have been amended to that extend.

6. this contract shall not be transferable or assignable in whole or part of any of parties hereto, provided that the owner may assign his rights and obligations in whole or in part or any other company which shall be entirely owned Company belonging to the same group of the companies as the owner, in such as event touch other company shall be either to act to as owner under this contract.

IN WITNESS WHEREOF the parties hereto have caused this Contract Agreement to be executed on the day, month and year first before written in accordance with their respective laws.

Mohammad

**MODERN ENGINEERING WORKS**  
**GOVERNMENT CONTRACTOR**

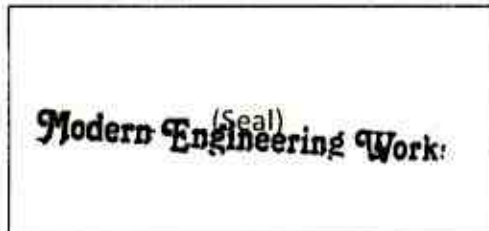

Nazar Muhammad Bozdar

**NAZAR MUHAMMAD BOZDAR**  
**DIRECTOR (F&A)**  
**PDMA, SINDH**



Signed, Sealed and Delivered in the presence of:

Witness:

Signature

Naveed Mal

Name

Naveed Mal

Title:

\_\_\_\_\_

CNIC:

42501-3743090-7

Witness:

Signature

Asim Kumar

Name

Asim Kumar

Title:

Asst. Director

CNIC:

42201-7942651-5



## COMPARATIVE STATEMENT

Name of Work: -

Provision and Installation of Hand Pump at Kohistan Area in District & Talukathatta Union Council Jungshahi,  
Chato Chand, Ongar (Deep Hand Pumps 86 & Shallow Hand Pumps 23-Nos)

Estimate Sanctioned by Chief Engineer Public Health Department Government of Sindh Vide Sanction Order No:DB/DWE/102 dated:-

13<sup>th</sup> January 2015

Tender invited vide letter No:-PDMA/1275 Dated:-24<sup>th</sup> December 2014

Date of Submission:-14-01-2015 Upto 2:00 PM

Date of Opening:-14-01-2015 at 2:30-PM

DESCRIPTION	Estimates cost	AMOUNT	Rate quoted by the contractor/firm M/S:-NAVETMAL	SAVING	PERCENT	REMARKS
Cost of Schedule Items		Rs:-13,108-M	Cost of Schedule Items @rate At Par	Rs:-13,108-M		
<b>Cost Non Schedule Items</b>			<b>Cost of Non Schedule</b>			
Hand Deep Pump Rs:25000/= Each		Rs:-2,150-M	Hand Deep Pump Rs:-24500/= Each	Rs:-2,107-M		
Shallow Pump Rs: 7000/= Each		Rs:-0,161-M	Shallow Pump Rs: 6800/= Each	Rs:-0,156-M		
UPVC Class "E" Pipe Rs:-72.70 P-Rft		Rs:-0,937-M	UPVC Class "F" Pipe Rs:-68/= P-Rft	Rs:-0,877-M		
<b>Total Cost</b>		<b>Rs:-16,356-M</b>	<b>Total Cost</b>	<b>Rs:-16,248-M</b>	<b>Rs:-0,108-M</b>	<b>0.66%</b>

@ The Rate of At Par Quoted by M/S: Navetmal Government Contractor on Schedule Items along with Quoted rate which comes to Rs:-16,248-Million found lowest and approved.

*Nazar*  
NAZAR KHAN  
DIRECTOR (FINANCE & ACCOUNTS) (CHARMAN)  
PROVINCIAL DISASTER MANAGEMENT AUTHORITY  
GOVERNMENT OF SINDH KARACHI



*Bhanani*  
BHANANI SHANTAR  
PUBLIC HEALTH DEPARTMENT (IGD) (MEMBER)  
GOVERNMENT OF SINDH

*Prasad*  
PRASAD PRADEEP SINGH  
DEPUTY DIRECTOR (HQ&F) (MEMBER)  
(PDMA) GOS KARACHI

*Ghulam*  
GHULAM HAJMATS QADANI  
FOREST & WILDLIFE DEPARTMENT (MEMBER)  
GOVERNMENT OF SINDH

*Hussain*  
HUSSEIN MEER  
CIVIL ENGINEER (MEMBER)  
(PDMA) GOS KARACHI

**BID EVALUATION REPORT**

1.	Name of Procuring Agency	Provincial Disaster Management Authority Government of Sindh Karachi				
2.	Tender Reference No:	NIT NO:PDMA/1275 Dated the 24 <sup>th</sup> December 2014				
3.	Tender Description/Name of Work/Items	Provision and installation of Deep Hand Pump at Kohistan Area in District & Taluka Thatta Union Council Jungshahi Chato Chand, Ongar (Deep hand Pumps 86 & Shallow Hand Pump 23-Nos)				
4.	Method of Procurement	Single Step-Two Envelope Method				
5.	Tender Published (Print & Electronic Media)(SPPRA ID No: & News Papers names with dated	On Print Media On Sindh Government Website (SPPRA) Photo copies of Newspaper attached PDMA Website				
6.	Total Bid documents sold	5-Nos				
7.	Total Bid Received	5-Nos				
8.	Technical Bid Opening date (if applicable) Provide detail on separate form)	14-01-2015.				
9.	No of Bid Technically qualified (if applicable)	1-Nos				
10.	Bids Rejected	4-Nos				
11.	Financial Bid Opening date.	29-01-2015 at 2.00-PM				
12.	Comparative Statement	Photo Copy attached herewith				
<b>S.NOS</b>	<b>Name of Firm or Bidder</b>	<b>Cost of offered by the Bidder</b>	<b>Ranking in items of cost</b>	<b>Comparison with Estimate cost</b>	<b>Reasons for acceptance/rejection</b>	<b>Remarks</b>
1.	M/S: Navetmal	Rs:- 16.248-M	1st	Rs:-16.356-M	Lowest	Accepted

  
**NAZAR MUHAMMAD BOZDAR**  
 DIRECTOR (F&A) (CHAIRMAN)  
 PROVINCIAL DISASTER MANAGEMENT AUTHORITY  
 GOVERNMENT OF SINDH KARACHI

  
**ABDUL SAMI SIDDIQUI**  
 DEPUTY DIRECTOR (H&C) SECRETARY  
 (PDMA) GOS KARACHI

  
**ABDUL SAMI MEMON**  
 CIVIL ENGINEER (MEMBER)  
 (PDMA) GOVERNMENT OF SINDH

  
**BHAWANIS SHANKAR**  
 PUBLIC HEALTH DEPARTMENT (LGD) (MEMBER)  
 GOVERNMENT OF SINDH



  
**GHULAM MUHAMMAD GADANI**  
 FOREST & WILDLIFE DEPARTMENT (MEMBER)  
 GOVERNMENT OF SINDH

# COMPARATIVE STATEMENT

Name of Work: -

Provision and Installation of Hand Pump at Kohistan Area in District Dadu/Talukalohi Union Council Toor Sawaro Channi, Phulji and TR Khan (Deep hand Pumps 163-Nos

Estimate Sanctioned by Chief Engineer Public Health Department Government of Sindh Vide Sanction Order No:DB/DWE/100 dated:-

13<sup>th</sup> January 2015

Tender invited vide letter No:-PDMA/1275 Dated:-24<sup>th</sup> December 2014

Date of Submission:-14-01-2015 Upto 2.00-PM

Date of Opening:-14-01-2015 at 2.30-PM

DESCRIPTION	Estimates cost	AMOUNT	Rate quoted by the contractor/firm	M/S:-MODERN ENGINEERING WORK	SAVING	PERCENT	REMARKS
Cost of Schedule Items		Rs:-21,911-M		Cost of Schedule Items @rate At Par	Rs:-21,911-M		
Cost Non Schedule Items				Cost of Non Schedule			
Hand Deep Pump Rs:25000/= Each		Rs:-4,075-M		Hand Deep Pump Rs: 24500/= Each	Rs:-3,993-M		
UPVC Class "E" Pipe Rs:-72 70 P-Rft		Rs:-1,777-M		UPVC Class "E" Pipe Rs:-65/= P-Rft	Rs:-1,613-M		
<b>Total Cost</b>		<b>Rs:-27,763-M</b>		<b>Total Cost</b>	<b>Rs:-27,518-M</b>	<b>Rs:-0.245-M</b>	<b>0.88%</b>

@ The Rate of A Par Quoted by M/S: Modern Engineering Work Government Contractor on Schedule Items along with Quoted rate which comes to Rs:-27,518-M Million found lowest and approved

*(Signature)*  
**SYAZAR MUHAMMAD BOZ ANG**  
 DIRECTOR (FINANCE & ACCOUNTS) (CHAIRMAN)  
 PROVINCIAL DISASTER MANAGEMENT AUTHORITY  
 GOVERNMENT OF SINDH KARACHI

*(Signature)*  
**DEPUTY DIRECTOR (PDMA) MEMBER**  
 (PDMA) GOS KARACHI

*(Signature)*  
**AGDUL SAMI (Member)**  
 CIVIL ENGINEER (MEMBER)  
 (PDMA) GOS KARACHI

*(Signature)*  
**BHAVANI SHANKAR**  
 PUBLIC HEALTH DEPARTMENT (IGD) (MEMBER)  
 GOVERNMENT OF SINDH

*(Signature)*  
**SHUJAH MUHAMMAD SHADANI**  
 FOREST & WILDLIFE DEPARTMENT (MEMBER)  
 GOVERNMENT OF SINDH



## BID EVALUATION REPORT

1.	Name of Procuring Agency	Provincial Disaster Management Authority Government of Sindh Karachi				
2.	Tender Reference No:	NIT NO:PDMA/1275 Dated the 24 <sup>th</sup> December 2014				
3.	Tender Description/Name of Work/Items	Provision and installation of Deep Hand Pump at Kohistan Area in District Dadu Taluka Johi Union Council Toor, Sawaro, Channi, Phulji and TR Khan (Deep hand Pumps 163-Nos)				
4.	Method of Procurement	Single Step-Two Envelope Method				
5.	Tender Published (Print & Electronic Media)(SPPRA ID No: & News Papers names with dated	On Print Media On Sindh Government Website (SPPRA) Photo copies of Newspaper attached PDMA Website				
6.	Total Bid documents sold	7-Nos				
7.	Total Bid Received	5-Nos				
8.	Technical Bid Opening date (if applicable) Provide detail on separate form)	14-01-2015.				
9.	No of Bid Technically qualified (if applicable)	1-Nos				
10.	Bids Rejected	4-Nos				
11.	Financial Bid Opening date	29-01-2015 at 2.00-PM				
12.	Comparative Statement	Photo Copy attached herewith				
S.NOS	Name of Firm or Bidder	Cost of offered by the Bidder	Ranking in items of cost	Comparison with Estimate cost	Reasons for acceptance/ rejection	Remarks
1.	M/S:- Modern Engineering Works	Rs- 27.518 M	1st	Rs- 27.763 M	Lowest	Accepted

  
**(SYED MUHAMMAD BOZDAR)**  
 DIRECTOR (F&A) (CHAIRMAN)  
 PROVINCIAL DISASTER MANAGEMENT AUTHORITY  
 GOVERNMENT OF SINDH KARACHI

  
**(FAROOQ AHMED SIDDIQUE)**  
 DEPUTY DIRECTOR (HQ&C) (SECRETARY)  
 (PDMA) GOS KARACHI

  
**(ABDUL SAMI MEMON)**  
 CIVIL ENGINEER (MEMBER)  
 (PDMA) GOVERNMENT OF SINDH

  
**(BHAWANI SHANKAR)**  
 PUBLIC HEALTH DEPARTMENT ((LGD) (MEMBER)  
 GOVERNMENT OF SINDH

  
**(GHULAM MUHAMMAD GADANI)**  
 FOREST & WILDLIFE DEPARTMENT (MEMBER)  
 GOVERNMENT OF SINDH



# COMPARATIVE STATEMENT

Name of Work :-

Provision and Installation of Hand Pump at Kohistan Area in District Jamshoro, Kotri, Manjhand&Sewan Union  
Council Sindh University Mohrojabal Amari manzorabad, Sun Laha and Jhangara (Deep hand Pumps 79-Nos

Estimate Sanctioned by Chief Engineer Public Health Department Government of Sindh Vide Sanction Order No:DB/DWE/101 dated:-  
13<sup>th</sup> January 2015

Tender invited vide letter No:-PDMA/1275 Dated:- 24<sup>th</sup> December 2014

Date of Submission:- 14-01-2015 Upto 2.00-PM

Date of Opening:- 14-01-2015 at 2.30-PM

DESCRIPTION	Estimates cost	Rate quoted by the contractor/firm	SAVING	PERCENT	REMARKS
Cost of Schedule Items	Rs:-10.619-M	Cost of Schedule Items @Rate At Par	Rs:-10.619-M		
<b>Cost Non Schedule Items</b>		<b>Cost of Non Schedule</b>			
Hand Deep Pump Rs:25000/= Each	Rs:-1.975-M	Hand Deep Pump Rs:-24500/= Each	Rs:-1.935-M		
UPVC Class "E" Pipe Rs:-72.70 P-RH	Rs:-0.861-M	UPVC Class "E" Pipe Rs:-67/= P-RH	Rs:-0.793-M		
<b>Total Cost</b>	<b>Rs:-13.456-M</b>	<b>Total Cost</b>	<b>Rs:-13.349-M</b>	<b>0.80%</b>	

@ The Rate of At Par Quoted by M/S: Nevatmal Government Contractor on Schedule Items along with Quoted rate which comes to Rs:-13.349. Million found lower and approved

*Nazam*  
**NAZAM MUHAMMAD BOZDAR**  
DIRECTOR (FINANCE & ACCOUNTS) (CHAIRMAN)  
PROVINCIAL DISASTER MANAGEMENT AUTHORITY  
GOVERNMENT OF SINDH KARACHI

*Bhawani Shankar*  
**BHAWANIS SHANKAR**  
PUBLIC HEALTH DEPARTMENT (LIGD) (MEMBER)  
GOVERNMENT OF SINDH



*Shahid*  
**DEPUTY DIRECTOR (HEAD) (MEMBER)**  
(PDMA) GOS KARACHI

*Abdul Same*  
**ABDUL SAME MEMON**  
CIVIL ENGINEER (MEMBER)  
(PDMA) GOS KARACHI

*Shahid*  
**SHAHID MUHAMMAD GHADANI**  
FOREST & WILDLIFE DEPARTMENT (MEMBER)  
GOVERNMENT OF SINDH

## BID EVALUATION REPORT

1.	Name of Procuring Agency	Provincial Disaster Management Authority Government of Sindh Karachi				
2.	Tender Reference No:	NIT NO:PDMA/1275 Dated the 24 <sup>th</sup> December 2014				
3.	Tender Description/Name of Work/Items:	Provision and installation of Deep Hand Pump at Kohistan Area in District Jamshoro, union Council Kotri, Manjhand, & Sewan Sindh University Mahro Jabal Amri Manzoorabad Lakha and Jhangara (Deep hand Pumps 79-Nos)				
4.	Method of Procurement	Single Step-Two Envelope Method				
5.	Tender Published (Print & Electronic Media)(SPPRA ID No: & News Papers names with dated	On Print Media On Sindh Government Website (SPPRA) Photo copies of Newspaper attached PDMA Website				
6.	Total Bid documents sold	6-Nos				
7.	Total Bid Received	6-Nos				
8.	Technical Bid Opening date (if applicable) Provide detail on separate form)	14-01-2015.				
9.	No of Bid Technically qualified (if applicable)	1-Nos				
10.	Bids Rejected	5-Nos				
11.	Financial Bid Opening date	29-01-2015 at 2.00-PM				
12.	Comparative Statement	Photo Copy attached herewith				
S.NOS	Name of Firm or Bidder	Cost of offered by the Bidder	Ranking in items of cost	Comparison with Estimate cost	Reasons for acceptance/rejection	Remarks
1.	M/S:- Navetmal	Rs:- 13.349-M	1st	Rs:-13.456-M	Lowest	Accepted

  
**(NAZAM MUHAMMAD BOZDAR)**  
 DIRECTOR (F&A) (CHAIRMAN)  
 PROVINCIAL DISASTER MANAGEMENT AUTHORITY  
 GOVERNMENT OF SINDH KARACHI

  
**ABDUL SAMI MEEMON**  
 CIVIL ENGINEER (MEMBER)  
 (PDMA) GOVERNMENT OF SINDH

  
**FAROOQUE AHMED SIDDIQUI**  
 DEPUTY DIRECTOR (HQ&C) (SECRETARY)  
 (PDMA) GOS KARACHI

  
**BHAWANI SHANKAR**  
 PUBLIC HEALTH DEPARTMENT ((LGD) (MEMBER)  
 GOVERNMENT OF SINDH



  
**GHULAM MUHAMMAD GADANI**  
 FOREST & WILDLIFE DEPARTMENT (MEMBER)  
 GOVERNMENT OF SINDH



## COMPARATIVE STATEMENT

Name of Work: Provision and Installation of Hand Pump at Kohistan Area in District and Taluka Thatta Union Council Jampur (Deep hand Pumps 174-Nos)

Estimate Sanctioned by Chief Engineer Public Health Department Government of Sindh Vide Sanction Order No: DB/DWE/105 dated: 13<sup>th</sup> January 2015

Tender invited vide letter No: PDMA/1275 Dated: 24<sup>th</sup> December 2014

Date of Submission: 14-01-2015 Upto 2:00 PM

Date of Opening: 14-01-2015 at 2:30 PM

DESCRIPTION	Estimates cost	AMOUNT	M/S:- B.S. TRADERS & ENGINEERING SERVICES	Rate quoted by the contractor/firm	SAVING	PERCENT	REMARKS
Cost of Schedule Items		Rs: 23,390-M	Cost of Schedule Items @rate At Par	Rs: 23,390			
Cost Non Schedule Items			Cost of Non Schedule				
Hand Deep Pump Rs: 25000/= Each		Rs: 4,350-M	Hand Deep Pump Rs: 24500/= Each	Rs: 4,263-M			
UPVC Class "E" Pipe Rs: 72.70 P-Rft		Rs: 1,897-M	UPVC Class "E" Pipe Rs: 66/= P-Rft	Rs: 1,722-M			
<b>Total Cost</b>	<b>Rs: 29,637-M</b>		<b>Total Cost</b>	<b>Rs: 29,375-M</b>	<b>Rs: 0.262-M</b>	<b>0.88%</b>	

@ The Rate of At Par Quoted by M/S: B.S. Traders Engineering Services Government Contractor on Schedule Items along with Quoted rate which comes to Rs: 29.375 Million found lowest and approved.

*(Signature)*  
 DIRECTOR (FINANCE & ACCOUNTS) (CHARMAN)  
 PROVINCIAL DISASTER MANAGEMENT AUTHORITY  
 GOVERNMENT OF SINDH KARACHI

*(Signature)*  
 DEPUTY DIRECTOR (HQ) MEMBER  
 (PDMA) GOS KARACHI

*(Signature)*  
 CIVIL ENGINEER (MEMBER)  
 (PDMA) GOS KARACHI

*(Signature)*  
 PUBLIC HEALTH DEPARTMENT (LGD) (MEMBER)  
 GOVERNMENT OF SINDH

*(Signature)*  
 FOREST & WILDLIFE DEPARTMENT (MEMBER)  
 GOVERNMENT OF SINDH



## BID EVALUATION REPORT

1.	Name of Procuring Agency	Provincial Disaster Management Authority Government of Sindh Karachi				
2.	Tender Reference No:	NIT NO:PDMA/1275 Dated the 24 <sup>th</sup> December 2014				
3.	Tender Description/Name of Work/Items	Provision and installation of Deep Hand Pump at Kohistan Area in District and Taluka Thatta Union Council Jhampir (Deep hand Pumps 174-Nos)				
4.	Method of Procurement	Single Step-Two Envelope Method				
5.	Tender Published (Print & Electronic Media)(SPPRA ID No: & News Papers names with dated	On Print Media On Sindh Government Website (SPPRA) Photo copies of Newspaper attached PDMA Website				
6.	Total Bid documents sold	7-Nos				
7.	Total Bid Received	5-Nos				
8.	Technical Bid Opening date (if applicable) Provide detail on separate form)	14-01-2015				
9.	No of Bid Technically qualified (if applicable)	1-Nos				
10.	Bids Rejected	4-Nos				
11.	Financial Bid Opening date	29-01-2015 at 2.00-PM				
12.	Comparative Statement	Photo Copy attached herewith				
S.NOS	Name of Firm or Bidder	Cost of offered by the Bidder	Ranking in items of cost	Comparison with Estimate cost	Reasons for acceptance/rejection	Remarks
1.	M/S:- B.S. Traders Engineering Services	Rs- 29.375-M	1st	Rs-29.637-M	Lowest	Accepted

  
 (MUZAL MUHAMMAD BOZDAR)  
 DIRECTOR (F&A) (CHAIRMAN)  
 PROVINCIAL DISASTER MANAGEMENT AUTHORITY  
 GOVERNMENT OF SINDH KARACHI

  
 (TARIQ ARIF) (SECRETARY)  
 DEPUTY DIRECTOR (HQ&C)  
 (PDMA) GOS KARACHI

  
 (JAVED SAMI) (MEMBER)  
 CIVIL ENGINEER  
 (PDMA) GOVERNMENT OF SINDH

  
 (SHAMA SHAKAR)  
 PUBLIC HEALTH DEPARTMENT (LGD) (MEMBER)  
 GOVERNMENT OF SINDH



  
 (GHULAM MUHAMMAD) (MEMBER)  
 FOREST & WILDLIFE DEPARTMENT  
 GOVERNMENT OF SINDH

# COMPARATIVE STATEMENT

Name of Work: - Provision and Installation of Hand Pump at Kohistan Area in District Jamshoro Taluka Thanabula Khan Union Council Tong (Deep hand Pumps 155-Nos

Estimate Sanctioned by Chief Engineer Public Health Department Government of Sindh Vide Sanction Order No:DB/DWE/107 dated: 13<sup>th</sup> January 2015

Tender invited vide letter No:-PDMA/1275 Dated:-24<sup>th</sup> December 2014

Date of Submission:- 14-01-2015 Upto 2.00-PM

Date of Opening:- 14-01-2015 at 2.30-PM

DESCRIPTION	Estimates cost	AMOUNT	M/S:-B.S. TRADERS ENGINEERING SERVICES	Rate quoted by the contractor/firm	SAVING	PERCENT	REMARKS
Cost of Schedule Items		Rs:-20,836-M	Cost of Schedule Items @rate At Par	Rs:-20,836-M			
<b>Cost Non Schedule Items</b>			<b>Cost of Non Schedule</b>				
Hand Deep Pump Rs:25000/= Each		Rs:- 3,875- M	Hand Deep Pump Rs:- 24500/= Each	Rs:- 3,797- M			
UPVC Class "E" Pipe Rs:-72.70 p-RH		Rs:-1,690-M	UPVC Class "E" Pipe Rs:-66/= p-RH	Rs:-1,534-M			
<b>Total Cost</b>		<b>Rs:-26,401-M</b>	<b>Total Cost</b>	<b>Rs:-26,168-M</b>	<b>Rs:-0.233-M</b>	<b>0.88%</b>	

@ The Rate of At Par Quoted by M/S: B.S. Traders Engineering Services Government Contractor on Schedule Items along with Quoted rate which comes to Rs:26.168 Million found lowest and approved.

*(Signature)*  
 CHAIRMAN  
 DIRECTOR (FINANCE & ACCOUNTS) (CHAIRMAN)  
 PROVINCIAL DISASTER MANAGEMENT AUTHORITY  
 GOVERNMENT OF SINDH KARACHI

*(Signature)*  
 DEPUTY DIRECTOR (HQS)  
 (PDMA) GOS KARACHI

*(Signature)*  
 CIVIL ENGINEER (MEMBER)  
 (PDMA) GOS KARACHI

*(Signature)*  
 PUBLIC HEALTH DEPARTMENT ((IGD) (MEMBER)  
 GOVERNMENT OF SINDH

*(Signature)*  
 FOREST & WILDLIFE DEPARTMENT (MEMBER)  
 GOVERNMENT OF SINDH





## BID EVALUATION REPORT

1.	Name of Procuring Agency	Provincial Disaster Management Authority Government of Sindh Karachi				
2.	Tender Reference No:	NIT NO:PDMA/1275 Dated the 24 <sup>th</sup> December 2014				
3.	Tender Description/Name of Work/Items	Provision and installation of Deep Hand Pump at Kohistan Area in District Jamshoro, Taluka Thana Bula Khan Union Council Tong (Deep hand Pumps 155-Nos)				
4.	Method of Procurement	Single Step-Two Envelope Method				
5.	Tender Published (Print & Electronic Media)(SPPRA ID No: & News Papers names with dated	On Print Media On Sindh Government Website (SPPRA) Photo copies of Newspaper attached PDMA Website				
6.	Total Bid documents sold	6-Nos				
7.	Total Bid Received	5-Nos				
8.	Technical Bid Opening date (if applicable) Provide detail on separate form)	14-01-2015:				
9.	No of Bid Technically qualified (if applicable)	1-Nos				
10.	Bids Rejected	4-Nos				
11.	Financial Bid Opening date	29-01-2015 at 2.00-PM				
12.	Comparative Statement	Photo Copy attached herewith				
S.NOS	Name of Firm or Bidder	Cost of offered by the Bidder	Ranking in items of cost	Comparison with Estimate cost	Reasons for acceptance/ rejection	Remarks
1.	M/S- B.S. Traders Engineering Services	Rs- 26.168-M	1st	Rs-26.401-M	Lowest	Accepted

  
 (Muhammad Bozdar)  
 DIRECTOR (F&A) (CHAIRMAN)  
 PROVINCIAL DISASTER MANAGEMENT AUTHORITY  
 GOVERNMENT OF SINDH KARACHI

  
 (Muhammad Siddiq)  
 DEPUTY DIRECTOR (HQ&C) (SECRETARY)  
 (PDMA) GOS KARACHI

  
 (Abdul Sami Awan)  
 CIVIL ENGINEER (MEMBER)  
 (PDMA) GOVERNMENT OF SINDH

  
 (Bhawani Shamsar)  
 PUBLIC HEALTH DEPARTMENT ((LGD) (MEMBER)  
 GOVERNMENT OF SINDH



  
 (Ghulam Muhammad Gadani)  
 FOREST & WILDLIFE DEPARTMENT (MEMBER)  
 GOVERNMENT OF SINDH

# COMPARATIVE STATEMENT

Name of Work: - Provision and Installation of Hand Pump at Kohistan Area in District Jamshoro Taluka Thanabula Khan Union Council Sari (Deep hand Pumps 155-Nos)

Estimate Sanctioned by Chief Engineer Public Health Department Government of Sindh Vide Sanction Order No:DB/DWE/106 dated:- 13<sup>th</sup> January 2015

Tender invited vide letter No:-PDMA/1275 Dated:-24<sup>th</sup> December 2014

Date of Submission:-14-01-2015 Upto 2:00:PM

Date of Opening:-14-01-2015 at 2:30:PM

DESCRIPTION	Estimates cost	AMOUNT	Rate quoted by the contractor/firm	M/S:-B.S. TRADERS ENGINEERING SERVICES	SAVING	PERCENT	REMARKS
Cost of Schedule Items		Rs:-19,973-M	Cost of Schedule Items @rate At Par	Rs:-19,973-M			
Cost Non Schedule Items			Cost of Non Schedule				
Hand Deep Pump Rs:25000/= Each		Rs:-3,000-M	Hand Deep Pump Rs:-24500/= Each	Rs:-2,940-M			
UPVC Class "E" Pipe Rs:-72.70 P-Rft		Rs:-1,308-M	UPVC Class "E" Pipe Rs:-66/= P-Rft	Rs:-1,188-M			
<b>Total Cost</b>		<b>Rs:-20,439-M</b>	<b>Total Cost</b>	<b>Rs:-20,259-M</b>	<b>Rs:-0.180-M</b>	<b>0.88%</b>	

@ The Rate of At Par Quoted by M/S: B.S. Traders Engineering Services Government Contractor on Schedule Items along with Quoted rate which comes to Rs:-20.259 Million found lowest and approved.

  
**(MAZAR MUHAMMAD SOZOME)**  
 DIRECTOR (FINANCE & ACCOUNTS) (CHAIRMAN)  
 PROVINCIAL DISASTER MANAGEMENT AUTHORITY  
 GOVERNMENT OF SINDH KARACHI

  
**FAROOQ AHMED SIDDIQUE**  
 DEPUTY DIRECTOR (HQ&C) (MEMBER)  
 (PDMA) GOS KARACHI

  
**ABU SAMI MEMON**  
 CIVIL ENGINEER (MEMBER)  
 (PDMA) GOS KARACHI

  
**BAHAUDDIN SHAUKAT**  
 PUBLIC HEALTH DEPARTMENT (ILGD) (MEMBER)  
 GOVERNMENT OF SINDH

  
**GHULAM MUHAMMAD GONDAL**  
 FOREST & WILDLIFE DEPARTMENT (MEMBER)  
 GOVERNMENT OF SINDH



## BID EVALUATION REPORT

1.	Name of Procuring Agency	Provincial Disaster Management Authority Government of Sindh Karachi				
2.	Tender Reference No:	NIT NO:PDMA/1275 Dated the 24 <sup>th</sup> December 2014				
3.	Tender Description/Name of Work/Items	Provision and installation of Deep Hand Pump at Kohistan Area in District Jamshoro Taluka Thana Bula Khan Union Council Sari (Deep hand Pumps <del>120</del> Nos)				
4.	Method of Procurement	Single Step-Two Envelope Method				
5.	Tender Published (Print & Electronic Media)[SPPRA ID No: & News Papers names with dated	On Print Media On Sindh Government Website (SPPRA) Photo copies of Newspaper attached PDMA Website				
6.	Total Bid documents sold	7-Nos				
7.	Total Bid Received	5-Nos				
8.	Technical Bid Opening date (if applicable) Provide detail on separate form)	14-01-2015.				
9.	No of Bid Technically qualified (if applicable)	1-Nos				
10.	Bids Rejected	4 Nos				
11.	Financial Bid Opening date	29-01-2015 at 2.00-PM				
12.	Comparative Statement	Photo Copy attached herewith				
S.NOS	Name of Firm or Bidder	Cost of offered by the Bidder	Ranking in items of cost	Comparison with Estimate cost	Reasons for acceptance/rejection	Remarks
1.	M/S:- B.S. Traders Engineering Services	Rs:- 20.259-M	1st	Rs:-20.439-M	Lowest	Accepted

  
**(NAZAM MUHAMMAD BOZDAR)**  
 DIRECTOR (F&A) (CHAIRMAN)  
 PROVINCIAL DISASTER MANAGEMENT AUTHORITY  
 GOVERNMENT OF SINDH KARACHI

  
**ARDU ASAMI MEMON**  
 CIVIL ENGINEER (MEMBER)  
 (PDMA) GOVERNMENT OF SINDH

  
**(FAROOQ AHMED SIDDIQUE)**  
 DEPUTY DIRECTOR (HQ&C) (SECRETARY)  
 (PDMA) GOS KARACHI

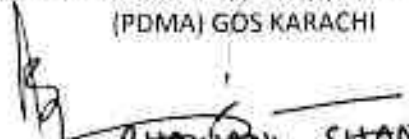
  
**BHAWANI SHANKER**  
 PUBLIC HEALTH DEPARTMENT ((LGD) (MEMBER)  
 GOVERNMENT OF SINDH

  
**GHULAM MUHAMMAD GADANI**  
 FOREST & WILDLIFE DEPARTMENT (MEMBER)  
 GOVERNMENT OF SINDH



## COMPARATIVE STATEMENT

Name of Work:-

**Provision and Installation of Hand Pump at Kohistan Area in District Jamshoro Talukabula Khan Union Council  
Mole and T. B. Khan (Deep hand Pumps 85-Nos**

Estimate Sanctioned by Chief Engineer Public Health Department Government of Sindh Vide Sanction Order No:DB/DWE/102 dated:-  
13<sup>th</sup> January 2015

Tender invited vide letter No:-PDMA/1275 Dated:- 24<sup>th</sup> December 2014

Date of Submission:- 14-01-2015 Upto 2.00-PM

Date of Opening:- 14-01-2015 at 2.30-PM

DESCRIPTION	Estimates cost	AMOUNT	Rate quoted by the contractor/firm	M/S:-NAVETMAL	SAVING	PERCENT	REMARKS
Cost of Schedule Items		Rs:-11,426-M	Cost of Schedule Items @rate At Par	Rs:-11,426-M			
<b>Cost Non Schedule Items</b>			<b>Cost of Non Schedule</b>				
Hand Deep Pump Rs:-25000/= Each		Rs:-2,125-M	Hand Deep Pump Rs:-24500/= Each	Rs:-2,082-M			
UPVC Class "E" Pipe Rs:-72.70 P-Rft		Rs:-0.926-M	UPVC Class "E" Pipe Rs:-68/= P-Rft	Rs:-0.867-M			
<b>Total Cost</b>		<b>Rs:-14,478-M</b>	<b>Total Cost</b>	<b>Rs:-14,375-M</b>	<b>Rs:-0.103-M</b>	<b>0.71%</b>	

@ The Rate of **A Par** Quoted by **M/S: Navetmal** Government Contractor on Schedule Items along with Quoted rate which comes to **Rs:-14,375-**  
Million found lowest and approved.

*(Signature)*  
DIRECTOR (FINANCE & ACCOUNTS) (CHAIRMAN)  
PROVINCIAL DISASTER MANAGEMENT AUTHORITY  
GOVERNMENT OF SINDH KARACHI

*(Signature)*  
DEPUTY DIRECTOR (HQS) (MEMBER)  
(PDMA) GOS KARACHI

*(Signature)*  
CIVIL ENGINEER (MEMBER)  
(PDMA) GOS, KARACHI

*(Signature)*  
PUBLIC HEALTH DEPARTMENT (LGD) (MEMBER)  
GOVERNMENT OF SINDH

*(Signature)*  
FOREST & WILDLIFE DEPARTMENT (MEMBER)  
GOVERNMENT OF SINDH



## BID EVALUATION REPORT

1.	Name of Procuring Agency	Provincial Disaster Management Authority Government of Sindh Karachi				
2.	Tender Reference No:	NIT NO:PDMA/1275 Dated the 24 <sup>th</sup> December 2014				
3.	Tender Description/Name of Work/Items	Provision and installation of Deep Hand Pump at Kohistan Area in District Jamshoro Taluka Thana Bula Khan Union Council Mole and T.B. Khan (Deep hand Pumps 85-Nos)				
4.	Method of Procurement	Single Step-Two Envelope Method				
5.	Tender Published (Print & Electronic Media)(SPPRA ID No: & News Papers names with dated	On Print Media On Sindh Government Website (SPPRA) Photo copies of Newspaper attached PDMA Website				
6.	Total Bid documents sold	5-Nos				
7.	Total Bid Received	4-Nos				
8.	Technical Bid Opening date (if applicable) Provide detail on separate form)	14-01-2015.				
9.	No of Bid Technically qualified (if applicable)	1-Nos				
10.	Bids Rejected	3-Nos				
11.	Financial Bid Opening date	29-01-2015 at 2.00-PM				
12.	Comparative Statement	Photo Copy attached herewith				
5.NOS	Name of Firm or Bidder	Cost of offered by the Bidder	Ranking in items of cost.	Comparison with Estimate cost	Reasons for acceptance/rejection	Remarks
1.	M/S:- Navetmal	Rs:- 14.375-M	1st	Rs:-14.478-M	Lowest	Accepted

  
 (MAZHAH MUHAMMAD BAZZAR)  
 DIRECTOR (F&A) (CHAIRMAN)  
 PROVINCIAL DISASTER MANAGEMENT AUTHORITY  
 GOVERNMENT OF SINDH KARACHI

  
 (FAROOQ AHMAD SIDDIQUI)  
 DEPUTY DIRECTOR (HQ&C) (SECRETARY)  
 (PDMA) GOS KARACHI

  
 (ASGHAR SAMI)  
 CIVIL ENGINEER (MEMBER)  
 (PDMA) GOVERNMENT OF SINDH

  
 (BHAWANJI SIMKAR)  
 PUBLIC HEALTH DEPARTMENT ((LGD) (MEMBER)  
 GOVERNMENT OF SINDH



  
 (GHULAM MUHAMMAD GADANI)  
 FOREST & WILDLIFE DEPARTMENT (MEMBER)  
 GOVERNMENT OF SINDH



## COMPARATIVE STATEMENT

Name of Work :

Provision and Installation of Hand Pump at Kohistan Area in District Dadu Taluk Jolhi Union Council Pot G Muhammad Dig Belafaredabad Choor and Burira (Deep hand Pumps 115-Nos

Estimate Sanctioned by Chief Engineer Public Health Department Government of Sindh Vide Sanction Order No: DB/DWE/108 dated: 13<sup>th</sup> January 2015

Tender invited vide letter No: PDMA/1275 Dated: 24<sup>th</sup> December 2014

Date of Submission: 14-01-2015 Upto 2.00-PM

Date of Opening: 14-01-2015 at 2.30-PM

DESCRIPTION	Estimates cost	AMOUNT	Rate quoted by the contractor/firm	SAVING	PERCENT	REMARKS
Cost of Schedule Items	Rs:-15,459 M	M/S:-MODERN ENGINEERING WORK	Cost of Schedule Items @rate At Par	Rs:-15,459 M		
Cost Non Schedule Items		Cost of Non Schedule				
Hand Deep Pump Rs:25000/= Each	Rs:-2,875-M	Hand Deep Pump Rs:-24500/= Each	Rs:-2,817-M			
UPVC Class "E" Pipe Rs: 72.70 P-Rft	Rs:-1,254-M	UPVC Class "E" Pipe Rs: 66/= P-Rft	Rs:-1,138-M			
<b>Total Cost</b>	<b>Rs:-19,588-M</b>	<b>Total Cost</b>	<b>Rs:-19,384-M</b>	<b>Rs:-0,204-M</b>	<b>1.04%</b>	

@ The Rate of At Par Quoted by M/S: Modern Engineering Work Government Contractor on Schedule Items along with Quoted rate which comes to Rs:-19,384 Million found lowest and approved.

*(Signature)*  
DIRECTOR (FINANCE & ACCOUNTS) (CHAIRMAN)  
PROVINCIAL DISASTER MANAGEMENT AUTHORITY  
GOVERNMENT OF SINDH KARACHI

*(Signature)*  
DEPUTY DIRECTOR (HORE) (MEMBER)  
(PDMA) GOS KARACHI

*(Signature)*  
CIVIL ENGINEER (MEMBER)  
(PDMA) GOS KARACHI

*(Signature)*  
PUBLIC HEALTH DEPARTMENT (LGD) (MEMBER)  
GOVERNMENT OF SINDH

*(Signature)*  
FOREST & WILDLIFE DEPARTMENT (MEMBER)  
GOVERNMENT OF SINDH



### BID EVALUATION REPORT

1.	Name of Procuring Agency	Provincial Disaster Management Authority Government of Sindh Karachi				
2.	Tender Reference No:	NIT NO:PDMA/1275 Dated the 24 <sup>th</sup> December 2014				
3.	Tender Description/Name of Work/Items	Provision and installation of Deep Hand Pump at Kohistan Area in District Dadu Taluka Johi Union Council Pot, G.Muhammad, Dig Bela, Fareedabad, Choor and Burira (Deep hand Pumps 115-Nos)				
4.	Method of Procurement	Single Step-Two Envelope Method				
5.	Tender Published (Print & Electronic Media)(SPPRA ID No. & News Papers names with dated	On Print Media On Sindh Government Website (SPPRA) Photo copies of Newspaper attached PDMA Website				
6.	Total Bid documents sold	6-Nos				
7.	Total Bid Received	5-Nos				
8.	Technical Bid Opening date (if applicable) Provide detail on separate form)	14-01-2015.				
9.	No of Bid Technically qualified (if applicable)	1-Nos				
10.	Bids Rejected	4-Nos				
11.	Financial Bid Opening date	29-01-2015 at 2.00-PM				
12.	Comparative Statement	Photo Copy attached herewith				
<b>S.NOS</b>	Name of Firm or Bidder	Cost of offered by the Bidder	Ranking in items of cost	Comparison with Estimate cost	Reasons for acceptance/rejection	Remarks
1.	M/S: Modern Engineering Works	Rs-19.384-M	1st	Rs-19.588-M	Lowest	Accepted

  
**FAYAZ MUHAMMAD BAZZANO**  
 DIRECTOR (F&W) (CHAIRMAN)  
 PROVINCIAL DISASTER MANAGEMENT AUTHORITY  
 GOVERNMENT OF SINDH KARACHI

  
**FAROOQ AHMED SIDDIQUE**  
 DEPUTY DIRECTOR (HQ&C) (SECRETARY)  
 (PDMA) GOS KARACHI





  
**ASIM SAMI MIRAN**  
 CIVIL ENGINEER (MEMBER)  
 (PDMA) GOVERNMENT OF SINDH

  
**BHAWANI SHAUKAT**  
 PUBLIC HEALTH DEPARTMENT ((LGD) (MEMBER)  
 GOVERNMENT OF SINDH



  
**GULAM MUHAMMAD SABANI**  
 FOREST & WILDLIFE DEPARTMENT (MEMBER)  
 GOVERNMENT OF SINDH

**Attendance Sheet**  
**Provision and Installation of Deep Head Pumps in Kohistan Areas**  
**Districts Jamshoro , Thatta and Dadu**  
**Meeting procurement committee for the opening of financial proposals**  
**Dated Thursday 29th, January 2015 @ 2.00 PM**

Sr #	Officer Name / Committee Member	Designation	Department	Cell No	Signature
1	A. Sami Memon	Civil Engineer	PDMA	03002766076	
2	Farooque A. Riddiq	DD(H) / Secty. R	PDMA	0321-2060132	
3	Bhawani Shanker	XEN	PHE Badli	033334-88005	
4	Ghulam Mohammad Gohar	Deputy Conservator	Wild life	0322-9206666	
	Nazar M. Bhandar	Dir E & A	PDMA	0333-2633713	



**Attendance Sheet**  
**Provision and Installation of Deep Head Pumps in Kohistan Areas**  
**Districts Jamshoro , Thatta and Dadu**  
**Meeting procurement committee for the opening of financial proposals**  
**Dated Thursday 29th, January 2015 @ 2.00 PM**

Sr #	Name of Firm/ Contractor	Cell No	Signature
(1)	MODERN ENGINEERING WORKS Mohan Mal	03033396966	Mohan Mal
2	NEEVAT MAL	03002875472	
(3)	B.S TRADERS	03213234198	

