

# SINDH PUBLIC PROCUREMENT REGULATORY AUTHORITY

## CONTRACT EVALUATION FORM

TO BE FILED IN BY ALL PROCURING AGENCIES FOR PUBLIC CONTRACTS OF WORKS, SERVICES & GOODS.

- 1). NAME OF THE ORGANIZATIN DEPTT: Executive Engineer Highway Division Shaheed Benazir Abad.
- 2). PROVINCIAL / LOCAL GOVT: / OTHER: District Government
- 3). TITLE OF CONTRACT: Constt: of road from Nawabshah Sarhari road to Connect Nawabshah Varr road Via Haji Muhammad Bux Brohi, Allah Ditto Magsi, Haji Jan Muhammad Brohi & Ghulam Hyder Zardari UC Khadhar & Gupchani Taluka Sakrand & Daur mile 0/0-3/2. A.D.P NO. 1171.
- 4). TENDER NUMBER E.E Highway TC/G-55/346, Dated 07-03-2016.
- 5). BRIEF DESCRIPTION OF CONTRACT \_\_\_\_\_
- 6). FORUM THAT APPROVED THE SCHEME: (A.D.P NO. 1171)
- 7). TENDER ESTIAMTED VALUE: 48.00 (M)
- 8). ENGINEER'S ESTIMATE 47.576 (M)  
(For civil works quality).
- 9). ESTIMATED COMPLETION PERIOD (AS PER CONTRACT) (15) Months
- 10). TENDER OPENED ON (DATE & TIME) 29-03-2016
- 11). NUMBER OF TENDER DOCUMENTS SLOD 06 Nos  
(Attach list of buyers)
- 12). NUMBER OF BIDS RECEIVED 06 Nos
- 13). NUMBER OF BIDDERS PRESENT AT THE TIME OF OPENING OF BIDS 06 Nos
- 14). BID EVALUATION REPORT Already sent
- 15). NAME AND ADDRESS OF THE SUCCESSFUL BIDDER Mr. Muhammad Akram Shaikh
- 16). CONTRACT AWARD PRICE 46934809
- 17). RAKING OF SUCCESSFUL BIDDER IN EVALUATION REPORT (1) Mr. Muhammad Akram Shaikh  
(i.e. 1<sup>st</sup>, 2<sup>nd</sup>, 3<sup>rd</sup> EVALUATION) (2) M/S Muhammad Ramzan Brohi & Co:  
(3) M/S Khalil Engg: Works  
(4) M/S Abdul Ghaffar Memon  
(5) M/S Crescent Engg: Works  
(6) M/S Atta Muhammad Bughio
- 18). MEHTOD OF PROCUREMENT USED (Tick one)
- a). SINGLE STAGE - ONE ENVELOPE PROCEDURE \_\_\_\_\_  Domicile / Local
- b). SINGLE STAGE - TWO ENVELOPE PROCEDURE \_\_\_\_\_
- c). TWO STAGE BIDDING PROCEDURE \_\_\_\_\_
- d). TWO STAGE TWO ENVELOPE PROCEDURE \_\_\_\_\_

PLEASE SPECIFY IF ANY OTHER MEHTOD OF PROCUREMENT WAS ADOPTED i.e. EMERGENCY, DIRECT CONTRACTING ETC. WITH BRIEF REASONS.

19). APPROVING AUTHORITY FOR AWARD OF CONTRACT

20). WHETHER THE PROCUREMENT WAS INCLUDED IN ANNUAL PROCUREMENT PLANT

Yes	<input checked="" type="checkbox"/>	No	<input type="checkbox"/>	<input type="checkbox"/>
-----	-------------------------------------	----	--------------------------	--------------------------

21). ADVERTISEMENT:

i). SPPRA Website

(If yes, give date and SPPRA Identification No)

Yes	SPPRA S.NO. 26875			
No				

ii). News Papers

(If yes, give names of newspapers and dates)

Jang Urdu dt: 14-03-2016, Sobh Sindhi dt: 11-03-2016,  
Ibrat Sindhi dt: 11-03-2016. & Dawn English dt: 11-03-2016.

Yes	<input checked="" type="checkbox"/>			
No				

22). NATURE OF CONTRACT

	<input checked="" type="checkbox"/>			Int
--	-------------------------------------	--	--	-----

23). WHETHER QUALIFICATION CRITERIA WAS INCLUDED IN BIDDING TENDER DOCUMENTS?

(If yes, enclose a copy)

Yes	<input checked="" type="checkbox"/>	No	<input type="checkbox"/>	<input type="checkbox"/>
-----	-------------------------------------	----	--------------------------	--------------------------

24). WHETHER BID EVALUATION CRITERIA WAS INCLUDED IN BIDDING TENDER DOCUMENTS?

(If yes, enclose a copy)

Yes	<input checked="" type="checkbox"/>	No	<input type="checkbox"/>	<input type="checkbox"/>
-----	-------------------------------------	----	--------------------------	--------------------------

25). WHETHER APPROVAL OF COMPETENT AUTHORITY WAS OBTAINED FOR USING A METHOD OTHER THAN OPEN COMPETITIVE BIDDING.

Yes	<input type="checkbox"/>	No	<input checked="" type="checkbox"/>	<input type="checkbox"/>
-----	--------------------------	----	-------------------------------------	--------------------------

26). WAS BID SECURITY OBTAINED FROM ALL THE BIDDERS?

Yes	<input checked="" type="checkbox"/>	No	<input type="checkbox"/>	<input type="checkbox"/>
-----	-------------------------------------	----	--------------------------	--------------------------

27). WETHER THE SUCCESSFUL BID WAS LOWEST EVALUATED BID/ BEST EVALUATED BID (in case of Consultancies)

Yes	<input checked="" type="checkbox"/>	No	<input type="checkbox"/>	<input type="checkbox"/>
-----	-------------------------------------	----	--------------------------	--------------------------

28). WETHER THE SUCCESSFUL BIDDER WAS TECHNICALLY COMPLAIANT?

Yes	<input checked="" type="checkbox"/>	No	<input type="checkbox"/>	<input type="checkbox"/>
-----	-------------------------------------	----	--------------------------	--------------------------

29). WHETHER NAMES OF BIDDERS AND THEIR QUOTED PRICES WERE READ OUT AT THE TIME OF OPENING OF BIDS?

Yes	<input checked="" type="checkbox"/>	No	<input type="checkbox"/>	<input type="checkbox"/>
-----	-------------------------------------	----	--------------------------	--------------------------

30). WHETHER EVALUATION REPORT GIVEN TO BIDDERS BEFORE THE AWARD OF CONTRACT?

(Attached copy of the bid evaluation report)

Yes	<input checked="" type="checkbox"/>	No	<input type="checkbox"/>	<input type="checkbox"/>
	<input checked="" type="checkbox"/>			

31). ANY COMPLAINTS RECEIVED  
(If yes, result thereof)

Yes		
✓ No		

32). ANY DEVIATION FROM SPECIFICATIONS GIVEN IN THE TENDER NOTICE / DOCUMENTS  
(If yes, give details)

Yes		
✓ No		

33). WAS THE EXTENSION MADE IN RESPONSE TIME?  
(If yes, give reasons)

Yes		✓ No	
-----	--	------	--

34). DEVIATION FROM QUALIFICATION CRITERIA  
(If yes, give details reasons)

Yes		✓ No	
-----	--	------	--

35). WAS IT ASSURED BY THE PROCURING AGENCY THAT THE SELECTED FIRM IS NOT  
BLACK LISTED?

Yes	✓	No	
-----	---	----	--

36). WAS A VISIT MADE BY ANY OFFICER OFFICIALS OF THE PROCURING AGENCY TO THE  
SUPPLIER 'S IN CONNECTIN WITH THE PROCUREMENT IF SO DETIALS TO BE  
ASSERIAINED REGARDING FINANCING OF VISIT IF ABROAD?  
(If yes, enclosed a copy).

Yes		No	✓
-----	--	----	---

37). WHERE PROPER SAFEFUARDS PROVIDED ON MOBILIZATION ADVANCE PAYMENT IN THE  
CONTRACT (BANK GUARANTEE ETC)?

Yes		No	
-----	--	----	--

38). SPECIAL CONDITION, IF ANY  
(If yes, give Brief Description)

Yes			
No	✓		

Signature & Official Stamp of  
Authorized Officer

EXECUTIVE ENGINEER  
Highway Division  
Shaheed Benazirabad

FOR OFFICE USE ONLY



OFFICE OF THE  
**EXECUTIVE ENGINEER**

HIGHWAY DIVISION, SHAHEED BENAZIR ABAD.

No: TC/G-55/ 603 S.B.A. Dated. 6/5 /2016

**WORK ORDER**

To,

Mr. Muhammad Akram Shaikh,  
Government Contractor,  
NAWABSIAH.

**Subject:-** CONSTT: OF ROAD FROM NAWABSHAH SARHARI ROAD TO CONNECT NAWABSHAH VARR ROAD VIA HAJI MUHAMMAD BUX BROHI, ALLAH DITTO MAGSI, HAJI JAN MUHAMMAD BROHI & GHULAM HYDER ZARDARI UC KHADHAR & GUPCHANI TALUKA SAKRAND & DAUR MILE 0/0-3/2 A.D.P NO. 1171.

**Reference: -** Your tender dated. 29-03-2016.

Rate quoted by you Part -A @Rs: 2.29% Below (Two Point Twenty Nine Percent Below) for road component Part A, 14.59% Above (Fourteen Point Fifty Nine Percent Above) for RCC Pipe component Part B, & 20.90% Above (Twenty Point Ninety Percent Above) for Masonry Structure component Part C, of the estimated rates entered in Schedule 'B' for the above work have been approved by the Chief Engineer, Highways Hyderabad vide letter No. H (8) / Shaheed Benazir Abad - (D.G) / (Tender) - c (i) /1134, Dated: 13-04-2016 & forwarded by the Superintending Engineer, Works and Services, Shaheed Benazir Abad vide his office letter No: BB/T/727 Dated: 14-04-2016 being the lowest.

You are therefore directed to please start the work within 7(Seven) days under the instruction from Assistant Engineer, concerned.

The period for the completion of the work is (15) (Fifteen) month and you are instructed to complete the same within the Schedule period and as per P.W.D. Specifications.

Also please attend the Divisional Office immediately to sign the tender documents and get the agreement stamped from Treasury Officer/District Accounts Officer, Shaheed Benazir Abad, otherwise no payment will be made.

EXECUTIVE ENGINEER  
HIGHWAY DIVISION  
SHAHEED BENAZIR ABAD

Copy forwarded to the Assistant Engineer, Highway Sub-Division, Sakrand, for information. He is directed to please intimate the actual date of start of the work in due course.

Certified copies of the Schedule 'A' & 'B' are enclosed herewith for office record.

EXECUTIVE ENGINEER  
HIGHWAY DIVISION  
SHAHEED BENAZIR ABAD



# FORM OF CONTRACT AGREEMENT

THIS CONTRACT AGREEMENT made on the 9th day of May 2017 between Executive Engineer, Highway Division, Shaheed Benazir Abad) of the one part and \_\_\_\_\_ of the other part.

Agency: Mr. Muhammad Akram Sheikh.

WHEREAS the Procuring Agency is desirous that certain Works, viz **CONSTT: OF ROAD FROM NAWABSHAH SARHARI ROAD TO CONNECT NAWABSHAH VARR ROAD VIA HAJI MUHAMMAD BUX BROHI, ALLAH DITTO MAGSI, HAJI JAN MUHAMMAD BROHI & GHULAM HYDER ZARDARI UC KHADHAR & GUPCHANI TALUKA SAKRAND & DAUR MILE 0/0-3/2.** should be executed by the Contractor and has accepted a Bid by the Contractor for the execution and completion of such Works and the remedying of any defects therein.

NOW this Agreement witnesses as follows:

1. In this Agreement words and expressions shall have the same meanings as are respectively assigned to them in the Conditions of Contract hereinafter referred to.

2. The following documents after incorporating addenda if any except those

Tender Amount

Rs = 4693480/-

Rs = 14



(CONTRACTOR)

EXECUTIVE ENGINEER  
HIGHWAY DIVISION  
SHAHEED BENAZIR ABAD

DIVISIONAL ACCOUNTS OFFICER  
HIGHWAY DIVISION,  
SHAHEED BENAZIR ABAD

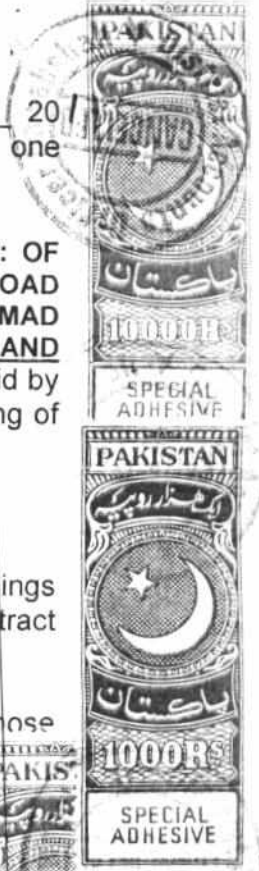

## FORM OF CONTRACT AGREEMENT

THIS CONTRACT AGREEMENT made on the 9<sup>th</sup> day of May 2016 between Executive Engineer, Highway Division, Shaheed Benazir Abad) of the one part and \_\_\_\_\_ of the other part.

Agency: Mr. Muhamad Akram Sheikh

WHEREAS the Procuring Agency is desirous that certain Works, viz **CONSTITUTION OF ROAD FROM NAWABSHAH SARHARI ROAD TO CONNECT NAWABSHAH VARR ROAD VIA HAJI MUHAMMAD BUX BROHI, ALLAH DITTO MAGSI, HAJI JAN MUHAMMAD BROHI & GHULAM HYDER ZARDARI UC KHADHAR & GUPCHANI TALUKA SAKRAN & DAUR MILE 0/0-3/2.** should be executed by the Contractor and has accepted a Bid by the Contractor for the execution and completion of such Works and the remedying of any defects therein.

NOW this Agreement witnesses as follows:

1. In this Agreement words and expressions shall have the same meanings as are respectively assigned to them in the Conditions of Contract hereinafter referred to.
2. The following documents after incorporating addenda, if any except those parts relating to Instructions to Bidders, shall be deemed to form and be read and construed as part of this Agreement, viz:
  - (a) The Letter of Acceptance;
  - (b) The completed Form of Bid along with Schedules to Bid;
  - (c) Conditions of Contract & Contract Data;
  - (d) The priced Schedule of Prices/Bill of quantities (BoQ);
  - (e) The Specifications; and
  - (f) The Drawings
3. In consideration of the payments to be made by the Procuring Agency to the Contractor as hereinafter mentioned, the Contractor hereby covenants with the Procuring Agency to execute and complete the Works and remedy defects therein in conformity and in all respects within the provisions of the Contract.
4. The Procuring Agency hereby covenants to pay the Contractor, in consideration of the Execution and completion of the Works as per provisions of the Contract, the Contract Price or such other sum as may become payable under the provisions of the Contract at the times and in the manner prescribed by the Contract.

IN WITNESS WHEREOF the parties hereto have caused this Contract Agreement to be executed on the day, month and year first before written in accordance with their respective laws.

  
(CONTRACTOR)

  
EXECUTIVE ENGINEER  
HIGHWAY DIVISION  
SHAHEED BENAZIR ABAD

  
DIVISIONAL ACCOUNTS OFFICER  
HIGHWAY DIVISION,  
SHAHEED BENAZIR ABAD

# CONDITIONS OF CONTRACT

## 1. GENERAL PROVISIONS

### 1.1 Definitions

In the Contract as defined below, the words and expressions defined shall have the following meanings assigned to them, except where the context requires otherwise:

#### The Contract

1.1.1 —Contract<sup>II</sup> means the Contract Agreement and the other documents listed in the Contract Data.

1.1.2 —Specifications<sup>II</sup> means the document as listed in the Contract Data, including Procuring Agency's requirements in respect of design to be carried out by the Contractor (if any), and any Variation to such document.

1.1.3 —Drawings<sup>II</sup> means the Procuring Agency's drawings of the Works as listed in the Contract Data, and any Variation to such drawings.

#### Persons

1.1.4 —Procuring Agency<sup>II</sup> means the person named in the Contract Data and the legal successors in title to this person, but not (except with the consent of the Contractor) any assignee.

1.1.5 —Contractor<sup>II</sup> means the person named in the Contract Data and the legal successors in title to this person, but not (except with the consent of the Procuring Agency) any assignee.

1.1.6 —Party<sup>II</sup> means either the Procuring Agency or the Contractor.

#### Dates, Times and Periods

1.1.7 —Commencement Date<sup>II</sup> means the date fourteen (14) days after the date the Contract comes into effect or any other date named in the Contract Data.

1.1.8 —Day<sup>II</sup> means a calendar day

1.1.9 —Time for Completion<sup>II</sup> means the time for completing the Works as stated in the Contract Data (or as extended under Sub-Clause 7.3), calculated from the Commencement Date.

#### Money and Payments

1.1.10 —Cost<sup>II</sup> means all expenditure properly incurred (or to be incurred) by the Contractor, whether on or off the Site, including overheads and similar charges but

  
**Contractor**

35  
  
**EXECUTIVE ENGINEER**  
Highway Division  
Shehed Benazirabad  

does not include any allowance for profit.

#### Other definitions

1.1.11 —Contractor's Equipmentll means all machinery, apparatus and other things required for the execution of the Works but does not include Materials or Plant intended to form part of the Works.

1.1.12 —Countryll means the Islamic Republic of Pakistan.

1.1.13 —Procuring Agency's Risksll means those matters listed in Sub-Clause 6.1.

1.1.14 —Force Majeurell means an event or circumstance which makes performance of a Party's obligations illegal or impracticable and which is beyond that Party's reasonable control.

1.1.15 —Materialsll means things of all kinds (other than Plant) to be supplied and incorporated in the Works by the Contractor.

1.1.16 —Plantll means the machinery and apparatus intended to form or forming part of the Works.

1.1.17 —Sitell means the places provided by the Procuring Agency where the Works are to be executed, and any other places specified in the Contract as forming part of the Site.

1.1.18 —Variationll means a change which is instructed by the Engineer/Procuring Agency under Sub-Clause 10.1.

1.1.19 —Worksll means any or all the works whether Supply, Installation, Construction etc. and design (if any) to be performed by the Contractor including temporary works and any variation thereof.

1.1.20 —Engineerll means the person notified by the Procuring Agency to act as Engineer for the purpose of the Contract and named as such in Contract Data.

#### 1.2 Interpretation

Words importing persons or parties shall include firms and organizations. Words importing singular or one gender shall include plural or the other gender where the context requires.

#### 1.3 Priority of Documents

The documents forming the Contract are to be taken as mutually explanatory of one another. If an ambiguity or discrepancy is found in the documents, the priority of the documents shall be in accordance with the order as listed in the Contract Data.

  
**Contractor**

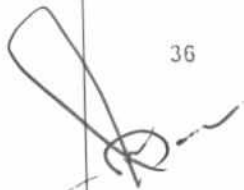
36  
  
**EXECUTIVE ENGINEER**  
Highway Division  
Shekhar Bazar Road  
Srinagar

#### 1.4 Law

The law of the Contract is the relevant Law of Islamic Republic of Pakistan.

#### 1.5 Communications

All Communications related to the Contract shall be in English language.

#### 1.6 Statutory Obligations

The Contractor shall comply with the Laws of Islamic Republic of Pakistan and shall give all notices and pay all fees and other charges in respect of the Works.

### 2. THE PROCURING AGENCY

#### 2.1 Provision of Site

The Procuring Agency shall provide the Site and right of access thereto at the times stated in the Contract Data.

**Site Investigation Reports** are those that were included in the bidding documents and are factual and interpretative reports about the surface and subsurface conditions at the Site.

#### 2.2 Permits etc.

The Procuring Agency shall, if requested by the Contractor, assist him in applying for permits, licenses or approvals which are required for the Works.

#### 2.3 Engineer's/Procuring Agency's Instructions

The Contractor shall comply with all instructions given by the Procuring Agency or the Engineer, if notified by the Procuring Agency, in respect of the Works including the suspension of all or part of the works.

#### 2.4 Approvals

No approval or consent or absence of comment by the Engineer/Procuring Agency shall affect the Contractor's obligations.

### 3. ENGINEER'S/PROCURING AGENCY'S REPRESENTATIVES

#### 3.1 Authorized Person

The Procuring Agency shall appoint a duly authorized person to act for him and on his behalf for the purposes of this Contract. Such authorized person shall be duly identified in the Contract Data or otherwise notified in writing to the Contractor as soon as he is so appointed. In either case the Procuring Agency shall notify the Contractor, in writing, the precise scope of the authority of such authorized person at the time of his appointment.

  
**Contractor**

37  
  
**EXECUTIVE ENGINEER**  
Highway Division  
Sheesh Benazirabad



### 3.2 Engineer's/Procuring Agency's Representative

The name and address of Engineer's/Procuring Agency's Representative is given in Contract Data. However the Contractor shall be notified by the Engineer/Procuring Agency, the delegated duties and authority before the Commencement of works.

### 4. THE CONTRACTOR

#### 4.1 General Obligations

The Contractor shall carry out the works properly and in accordance with the Contract. The Contractor shall provide all supervision, labour, Materials, Plant and Contractor's Equipment which may be required

#### 4.2 Contractor's Representative

The Contractor shall appoint a representative at site on full time basis to supervise the execution of work and to receive instructions on behalf of the Contractor but only after obtaining the consent of the Procuring Agency for such appointment which consent shall not be withheld without plausible reason(s) by the Procuring Agency. Such authorized representative may be substituted/ replaced by the Contractor at any time during the Contract Period but only after obtaining the consent of the Procuring Agency as aforesaid.

#### 4.3 Subcontracting

The Contractor shall not subcontract the whole of the works. The Contractor shall not subcontract any part of the works without the consent of the Procuring Agency.

#### 4.4 Performance Security

The Contractor shall furnish to the Procuring Agency within fourteen (14) days after receipt of Letter of Acceptance a Performance Security at the option of the bidder, in the form of Payee's order /Bank Draft or Bank Guarantee from scheduled bank for the amount and validity specified in Contract Data.

### 5. DESIGN BY CONTRACTOR

#### 5.1 Contractor's Design

The Contractor shall carry out design to the extent specified, as referred to in the Contract Data. The Contractor shall promptly submit to the Engineer/Procuring Agency all designs prepared by him, within fourteen (14) days of receipt the Engineer/Procuring Agency shall notify any comments or, if the design submitted is not in accordance with the Contract, shall reject it stating the reasons. The ,

  
Contractor

38  
  
EXECUTIVE ENGINEER  
Highway Division  
State Road Contractors

Contractor shall not construct any element of the works designed by him within fourteen (14) days after the design has been submitted to the Engineer/Procuring Agency or which has been rejected. Design that has been rejected shall be promptly amended and resubmitted. The Contractor shall resubmit all designs commented on taking these comments into account as necessary.

## 5.2 Responsibility for Design

The Contractor shall remain responsible for his bided design and the design under this Clause, both of which shall be fit for the intended purposes defined in the Contract and he shall also remain responsible for any infringement of any patent or copyright in respect of the same. The Engineer/Procuring Agency shall be responsible for the Specifications and Drawings.

## 6. PROCURING AGENCY'S RISKS

### 6.1 The Procuring Agency's Risks

The Procuring Agency's Risks are:-

- a) war, hostilities (whether war be declared or not), invasion, act of foreign enemies, within the Country;
- b) Rebellion, terrorism, revolution, insurrection, military or usurped power, or civil war, within the Country;
- c) riot, commotion or disorder by persons other than the Contractor's personnel and other employees including the personnel and employees of Sub- Contractors, affecting the Site and/or the Works;
- d) ionizing radiations, or contamination by radio-activity from any nuclear fuel, or from any nuclear waste from the combustion of nuclear fuel, radio-active toxic explosive, or other hazardous properties of any explosive nuclear assembly or nuclear component of such an assembly, except to the extent to which the Contractor/Sub-Contractors may be responsible for the use of any radio-active material;
- e) Pressure waves caused by aircraft or other aerial devices travelling at sonic or supersonic speeds;
- f) use or occupation by the Procuring Agency of any part of the Works, except as may be specified in the Contract;
- g) late handing over of sites, anomalies in drawings, late delivery of designs and drawings of any part of the Works by the Procuring Agency's personnel or by others for whom the Procuring Agency is responsible;
- h) a suspension under Sub-Clause 2.3 unless it is attributable to the Contractor's failure; and

  
**Contractor**

39  
  
**EXECUTIVE ENGINEER**  
**Highway Division**  
**Shree Benazir Road**



physical obstructions or physical conditions other than climatic conditions, encountered on the Site during the performance of the Works, for which the Contractor immediately notified to the Procuring Agency and accepted by the Procuring Agency.

## 7. TIME FOR COMPLETION

### 7.1 Execution of the Works

The Contractor shall commence the Works on the Commencement Date and shall proceed expeditiously and without delay and shall complete the Works, subject to Sub-Clause 7.3 below, within the Time for Completion.

### 7.2 Programme

Within the time stated in the Contract Data, the Contractor shall submit to the Engineer/Procuring Agency a programme for the Works in the form stated in the Contract Data.

### 7.3 Extension of Time

The Contractor shall, within such time as may be reasonable under the circumstances, notify the Procuring Agency/Engineer of any event(s) falling within the scope of Sub-Clause 6.1 or 10.3 of these Conditions of Contract and request the Procuring Agency/Engineer for a reasonable extension in the time for the completion of works. Subject to the aforesaid, the Procuring Agency/Engineer shall determine such reasonable extension in the time for the completion of works as may be justified in the light of the details/particulars supplied by the Contractor in connection with the such determination by the Procuring Agency/Engineer within such period as may be prescribed by the Procuring Agency/Engineer for the same; and the Procuring Agency may extend the time for completion as determined.

### 7.4 Late Completion

If the Contractor fails to complete the Works within the Time for Completion, the Contractor's only liability to the Procuring Agency for such failure shall be to pay the amount as liquidity damages stated in the Contract Data for each day for which he fails to complete the Works.

## 8. TAKING-OVER

### 8.1 Completion

The Contractor may notify the Engineer/Procuring Agency when he considers that the Works are complete.

  
Contractor

40  
  
EXECUTIVE ENGINEER  
Highway Division  
Shahd Benazir  
Sindh

## 8.2 Taking-Over Notice

Within fourteen (14) days of the receipt of the said notice of completion from the Contractor the Procuring Agency/Engineer shall either takeover the completed works and issue a Certificate of Completion to that effect or shall notify the Contractor his reasons for not taking-over the works. While issuing the Certificate of Completion as aforesaid, the Procuring Agency/Engineer may identify any outstanding items of work which the Contractor shall undertake during the Maintenance Period.

## 9. REMEDYING DEFECTS

### 9.1 Remediating Defects

The Contractor shall for a period stated in the Contract Data from the date of issue of the Certificate of Completion carry out, at no cost to the Procuring Agency, repair and rectification work which is necessitated by the earlier execution of poor quality of work or use of below specifications material in the execution of Works and which is so identified by the Procuring Agency/Engineer in writing within the said period. Upon expiry of the said period, and subject to the Contractor's faithfully performing his aforesaid obligations, the Procuring Agency/Engineer shall issue a Maintenance Certificate whereupon all obligations of the Contractor under this Contract shall come to an end.

Failure to remedy any such defects or complete outstanding work within a reasonable time shall entitle the Procuring Agency to carry out all necessary works at the Contractor's cost. However, the cost of remedying defects not attributable to the Contractor shall be valued as a Variation.

### 9.2 Uncovering and Testing

The Engineer/Procuring Agency may give instruction as to the uncovering and/or testing of any work. Unless as a result of an uncovering and/or testing it is established that the Contractor's design, materials, plant or workmanship are not in accordance with the Contract, the Contractor shall be paid for such uncovering and/or testing as a Variation in accordance with Sub-Clause 10.2.

## 10. VARIATIONS AND CLAIMS

### 10.1 Right to Vary

The Procuring Agency/Engineer may issue Variation Order(s) in writing. Where for any reason it has not been possible for the Procuring Agency/Engineer to issue such Variations Order(s), the Contractor may confirm any verbal orders given by the Procuring Agency/Engineer in writing and if the same are not refuted/denied by the Procuring Agency/Engineer within ten (10) days of the receipt of such confirmation the same shall be deemed to be a Variation Orders for the purposes of this Sub-Clause.

  
Contractor

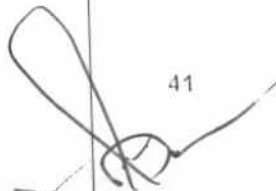
41  
  
EXECUTIVE ENGINEER  
Highway Division  
Shaheed Benazirabad

## 10.2 Valuation of Variations

Variations shall be valued as follows:

- a) at a lump sum price agreed between the Parties, or
- b) where appropriate, at rates in the Contract, or
- c) in the absence of appropriate rates, the rates in the Contract shall be used as the basis for valuation, or failing which
- d) at appropriate new rates, as may be agreed or which the Engineer/Procuring Agency considers appropriate, or
- e) if the Engineer/Procuring Agency so instructs, at day work rates set out in the Contract Data for which the Contractor shall keep records of hours of labour and Contractor's Equipment, and of Materials, used.

## 10.3 Changes in the Quantities.

- a) If the final quantity of the work done differs from the quantity in the Bill of Quantities for the particular item by more than 25 percent, provided the change exceeds 1 percent of the Initial Contract Price, the Procuring Agency/Engineer shall adjust the rate to allow for the change and will be valued as per sub clause 10.2.
- b) The Engineer shall not adjust rates from changes in quantities if thereby the Initial Contract Price is exceeded by more than 15 percent, except with the prior approval of the Procuring Agency.
- c) If requested by the Engineer, the contractor shall provide the Engineer with a detailed cost breakdown of any rate in the Bill of Quantities.

## 10.4 Early Warning

The Contractor shall notify the Engineer/Procuring Agency in writing as soon as he is aware of any circumstance which may delay or disrupt the Works, or which may give rise to a claim for additional payment.

To the extent of the Contractor's failure to notify, which results to the Engineer/Procuring Agency being unable to keep all relevant records or not taking steps to minimize any delay, disruption, or Cost, or the value of any Variation, the Contractor's entitlement to extension of the Time for Completion or additional payment shall be reduced/rejected.

## 10.5 Valuation of Claims

If the Contractor incurs Cost as a result of any of the Procuring Agency's Risks, the Contractor shall be entitled to the amount of such Cost. If as a result of any

  
**Contractor**

42  
  
**EXECUTIVE ENGINEER**  
Highway Division  
Shahrest Benazirabad

Procuring Agency's Risk, it is necessary to change the Works, this shall be dealt with as a Variation subject to Contractor's notification for intention of claim to the Engineer/Procuring Agency within fourteen (14) days of the occurrence of cause.

#### 10.6 Variation and Claim Procedure

The Contractor shall submit to the Engineer/Procuring Agency an itemized detailed breakdown of the value of variations and claims within twenty eight (28) days of the instruction or of the event giving rise to the claim. The Engineer/Procuring Agency shall check and if possible agree the value. In the absence of agreement, the Procuring Agency shall determine the value.

### 11. CONTRACT PRICE AND PAYMENT

#### 11.1 (a) Terms of Payments

The amount due to the Contractor under any Interim Payment Certificate issued by the Engineer pursuant to this Clause, or to any other terms of the Contract, shall, subject to Clause 11.3, be paid by the Procuring Agency to the Contractor within 30 days after such Interim Payment Certificate has been jointly verified by Procuring Agency and Contractor, or, in the case of the Final Certificate referred to in Sub Clause 11.5, within 60 days after such Final Payment Certificate has been jointly verified by Procuring Agency and Contractor;

Provided that the Interim Payment shall be caused in thirty (30) days and Final Payment in 60 days in case of foreign funded project. In the event of the failure of the Procuring Agency to make payment within 90 days then Procuring Agency shall pay to the Contractor compensation at the 28 days rate of KIBOR+2% per annum in local currency and LIBOR+1% for foreign currency, upon all sums unpaid from the date by which the same should have been paid.

#### (b) Valuation of the Works

The Works shall be valued as provided for in the Contract Data, subject to Clause 10.



#### 11.2 Monthly Statements

The Contractor shall be entitled to be paid at monthly intervals:

- a) the value of the Works executed less to the cumulative amount paid previously; and
- b) value of secured advance on the materials and valuation of variations (if any).

The Contractor shall submit each month to the Engineer/Procuring Agency a statement showing the amounts to which he considers himself entitled.

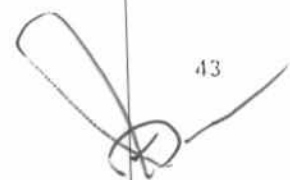
  
**Contractor**

43  
  
**ENGINEER**  
Highway Division  

### 11.3 Interim Payments

Within a period not exceeding seven (07) days from the date of submission of a statement for interim payment by the Contractor, the Engineer shall verify the same and within a period not exceeding thirty (30/60) days from the said date of submission by the Contractor, the Procuring Agency shall pay to the Contractor the sum subject to adjustment for deduction of the advance payments and retention money.

### 11.4 Retention

Retention money shall be paid by the Procuring Agency to the Contractor within fourteen (14) days after either the expiry of the period stated in the Contract Data, or the remedying of notified defects, or the completion of outstanding work, all as referred to in Sub-Clause 9.1, whichever is the later.

### 11.5 Final Payment

Within twenty one (21) days from the date of issuance of the Maintenance Certificate the Contractor shall submit a final account to the Engineer to verify and the Engineer shall verify the same within fourteen (14) days from the date of submission and forward the same to the Procuring Agency together with any documentation reasonably required to enable the Procuring Agency to ascertain the final contract value.

Within sixty (60) days from the date of receipt of the verified final account from the Engineer, the Procuring Agency shall pay to the Contractor any amount due to the Contractor. While making such payment the Procuring Agency may, for reasons to be given to the Contractor in writing, withhold any part or parts of the verified amount.

### 11.6 Currency

Payment shall be in the currency stated in the Contract Data.

## 12. DEFAULT

### 12.1 Defaults by Contractor

If the Contractor abandons the Works, refuses or fails to comply with a valid instruction of the Engineer/Procuring Agency or fails to proceed expeditiously and without delay, or is, despite a written complaint, in breach of the Contract, the Procuring Agency may give notice referring to this Sub-Clause and stating the default.

If the Contractor has not taken all practicable steps to remedy the default within fourteen (14) days after receipt of the Procuring Agency's notice, the Procuring Agency may by a second notice given within a further twenty one (21) days, terminate the Contract. The Contractor shall then demobilize from the Site leaving behind any Contractor's Equipment which the Procuring Agency instructs, in the second notice, to be used for the completion of the Works at the risk and cost of the Contractor.

  
Contractor

44  
  
EXECUTIVE ENGINEER  
Highway Division  
Shaheed Benazirabad

## 12.2 Defaults by Procuring Agency

If the Procuring Agency fails to pay in accordance with the Contract, or is, despite a written complaint, in breach of the Contract, the Contractor may give notice referring to this Sub-Clause and stating the default. If the default is not remedied within fourteen (14) days after the Procuring Agency's receipt of this notice, the Contractor may suspend the execution of all or parts of the Works.

If the default is not remedied within twenty eight (28) days after the Procuring Agency's receipt of the Contractor's notice, the Contractor may by a second notice given within a further twenty one (21) days, terminate the Contract. The Contractor shall then demobilize from the Site.

## 12.3 Insolvency

If a Party is declared insolvent under any applicable law, the other Party may by notice terminate the Contract immediately. The Contractor shall then demobilize from the site leaving behind, in the case of the Contractor's insolvency, any Contractor's Equipment which the Procuring Agency instructs in the notice is to be used for the completion of the Works.

## 12.4 Payment upon Termination

After termination, the Contractor shall be entitled to payment of the unpaid balance of the value of the works executed and of the Materials and Plant reasonably delivered to the site, adjusted by the following:

- a) any sums to which the Contractor is entitled under Sub-Clause 10.4,
- b) any sums to which the Procuring Agency is entitled,
- c) if the Procuring Agency has terminated under Sub-Clause 12.1 or 12.3, the Procuring Agency shall be entitled to a sum equivalent to twenty percent (20%) of the value of parts of the Works not executed at the date of the termination, and
- d) if the Contractor has terminated under Sub-Clause 12.2 or 12.3, the Contractor shall be entitled to the cost of his demobilization together with a sum equivalent to ten percent (10%) of the value of parts of the works not executed at the date of termination.

The net balance due shall be paid or repaid within twenty eight (28) days of the notice of termination.

## 13. RISKS AND RESPONSIBILITIES

### 13.1 Contractor's Care of the Works

Subject to Sub-Clause 9.1, the Contractor shall take full responsibility for the care

  
**Contractor**

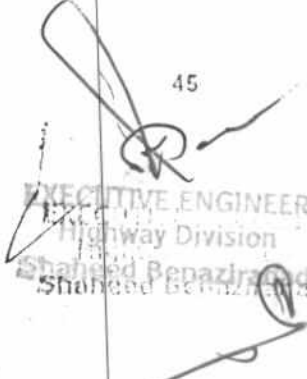
45  
  
**EXECUTIVE ENGINEER**  
Highway Division  
Shahid Benazir  
Shahid Benazir



of the Works from the Commencement Date until the date of the Procuring Agency's/Engineer's issuance of Certificate of Completion under Sub-Clause 8.2. Responsibility shall then pass to the Procuring Agency. If any loss or damage happens to the Works during the above period, the Contractor shall rectify such loss or damage so that the Works conform with the Contract.

Unless the loss or damage happens as a result of any of the Procuring Agency's Risks, the Contractor shall indemnify the Procuring Agency, or his agents against all claims loss, damage and expense arising out of the Works.

### 13.2 Force Majeure

If Force Majeure occurs, the Contractor shall notify the Engineer/Procuring Agency immediately. If necessary, the Contractor may suspend the execution of the Works and, to the extent agreed with the Procuring Agency demobilize the Contractor's Equipment.

If the event continues for a period of eighty four (84) days, either Party may then give notice of termination which shall take effect twenty eight (28) days after the giving of the notice.

After termination, the Contractor shall be entitled to payment of the unpaid balance of the value of the Works executed and of the Materials and Plant reasonably delivered to the Site, adjusted by the following:

- a) any sums to which the Contractor is entitled under Sub-Clause 10.4,
- b) the cost of his demobilization, and
- c) less any sums to which the Procuring Agency is entitled.

The net balance due shall be paid or repaid within thirty five (35) days of the notice of termination.

## 14. INSURANCE

### 14.1 Arrangements

The Contractor shall, prior to commencing the Works, effect insurances of the types, in the amounts and naming as insured the persons stipulated in the Contract Data except for items (a) to (e) and (i) of the Procuring Agency's Risks under Sub- Clause 6.1. The policies shall be issued by insurers and in terms approved by the Procuring Agency. The Contractor shall provide the Engineer/Procuring Agency with evidence that any required policy is in force and that the premiums have been paid.

### 14.2 Default

If the Contractor fails to effect or keep in force any of the insurances referred to in the previous Sub-Clause, or fails to provide satisfactory evidence, policies or receipts, the Procuring Agency may, without prejudice to any other right or

  
\_\_\_\_\_  
Contractor

46  
  
EXECUTIVE ENGINEER  
Highway Division  
Shaheed Benazirabad



remedy effect insurance for the cover relevant to such as a default and pay the premiums due and recover the same plus a sum in percentage given in Contractor Data from all other amounts due to the Contractor.

## 15. RESOLUTION OF DISPUTES

### 15.1 Engineer's Decision

If a dispute of any kind whatsoever arises between the Procuring Agency and the Contractor in connection with the works, the matter in dispute shall, in the first place, be referred in writing to the Engineer, with a copy to the other party. Such reference shall state that it is made pursuant to this Clause. No later than the twenty eight (28) days after the day on which he received such reference, the Engineer shall give notice of his decision to the Procuring Agency (Superintending Engineer) and the Contractor.

Unless the Contract has already been repudiated or terminated, the Contractor shall, in every case, continue to proceed with the work with all due diligence, and the Contractor and the Procuring Agency (Superintending Engineer) shall give effect forthwith to every such decision of the Engineer unless and until the same shall be revised, as hereinafter provided in an arbitral award.

### 15.2 Notice of Dissatisfaction

If a Party is dissatisfied with the decision of the Engineer of consultant or if no decision is given within the time set out in Sub-Clause 15.1 here above, the Party may give notice of dissatisfaction referring to this Sub-Clause within fourteen (14) days of receipt of the decision or the expiry of the time for the decision. If no notice of dissatisfaction is given within the specified time, the decision shall be final and binding on the Parties. If notice of dissatisfaction is given within the specified time, the decision shall be binding on the Parties who shall give effect to it without delay unless and until the decision of the Engineer is revised by an arbitrator.

If a contractor is dissatisfied with the decision of the Engineer of the department or decision is not given in time then he can approach Superintending Engineer within 14 days, in case of dissatisfaction with decision of Superintending Engineer or not decided within 28 days, then arbitration process would be adopted as per clause 15.3.

### 15.3 Arbitration

A dispute which has been the subject of a notice of dissatisfaction shall be finally settled as per provisions of Arbitration Act 1940 (Act No. X of 1940) and Rules made there under and any statutory modifications thereto. Any hearing shall be held at the place specified in the Contract Data and in the language referred to in Sub-Clause 1.5.



**Contractor**

47

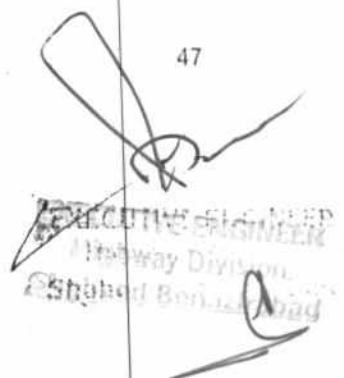

**EXECUTIVE ENGINEER**  
Highway Division  
Estahed Benha

## 16 INTEGRITY PACT

16.1 If the Contractor or any of his Sub-Contractors, agents or servants is found to have violated or involved in violation of the Integrity Pact signed by the Contractor as Schedule-F to his Bid, then the Procuring Agency shall be entitled to:

(a) recover from the Contractor an amount equivalent to ten times the sum of any commission, gratification, bribe, finder's fee or kickback given by the Contractor or any of his Sub-Contractors, agents or servants;

(b) Terminate the Contract; and

(c) Recover from the Contractor any loss or damage to the Procuring Agency as a result of such termination or of any other corrupt business practices of the Contractor or any of his Sub-Contractors, agents or servants. On termination of the Contract under Sub-Para (b) of this Sub-Clause, the Contractor shall demobilize from the site leaving behind Contractor's Equipment which the Procuring Agency instructs, in the termination notice, to be used for the completion of the works at the risk and cost of the Contractor. Payment upon such termination shall be made under Sub-Clause 12.4, in accordance with Sub-Para (c) thereof, after having deducted the amounts due to the Procuring Agency under Sub-Para (a) and (c) of this Sub-Clause.



(CONTRACTOR)



EXECUTIVE ENGINEER  
HIGHWAY DIVISION  
SHAHEED BENAZIR ABAD



DIVISIONAL ACCOUNTS OFFICER  
HIGHWAY DIVISION,  
SHAHEED BENAZIR ABAD

Bill Of Quantities

Sr. No: 02

Name of Work:-

Bill of Quantities SCHEDULE "B"

Constt: of road from Nawabshah Sarhari road to Connect Nawabshah Varr road Via Haji Muhammad Bux Brohi, Allah Ditto Magsi, Haji Jan Muhammad Brohi &amp; Ghulam Hyder Zardari UC Khadhar &amp; Gupchani Taluka Sakrand &amp; Daur mile 0/0-3/2.

S.No:	Quantity	Item of Work	Rate	Unit	Amount
1		<b>Earth work (Formation)</b>			
		Earth work for road embankment by bulldozers including ploughing mixing clod breaking dressing and compacting with optimum moisture contents lead upto 100" and lift upto 5" in all type of soil except rock.			
		<u>E/W 85% Density W.O.L</u>			
	584246	Cft	3656.23	% 0Cft	2136138
		<u>E/W 95-100% Density W.O.L</u>			
	126896	Cft	6190.17	% 0Cft	785508
		<u>E/W On Berms W.O.L</u>			
	134850	Cft	2208.37	% 0Cft	297799
		<u>E/W 85% Density W.E.L (1-0 Mile)</u>			
	619883	Cft	7723.95	% 0Cft	4787945
		<u>E/W 95-100% Density W.E.L (1-0 Mile)</u>			
	120542	Cft	10253.72	% 0Cft	1236001
		<u>E/W On Berms W.E.L (1-0 Mile)</u>			
	128107	Cft	6278.37	% 0Cft	804303
2		<b>Sub Base Course</b>			
		Preparing sub base course by supplying and spreading stone metal 1*11/2" gauge of approved quality from approved quarry in required thickness to proper camber and grade including hand packing, filling voids with 20 cft pit/ canal sand having plasticity index of not more than 6% of suitable quality, watering and compacting to achieve 98-100% density as per modified AASHO specification, Rate includes all cost of materials, T&P and carriage up to site of work.			
	106049	Cft	9600.40	% Cft	10181128
3		<b>Brick on End Edging</b>			
		Laying on bricks on end edging including supply of 9"x4 1/2"x3" 1st class burnt bricks excavation for laying edging with small size parallel to the road. Rate includes all cost of materials labour and carriage to the site of work.			
	35350	Rft	2813.32	% Rft	994509
4		<b>Base Course</b>			
		Preparing Base course by supplying and spreading stone metal of approved quality properly graded to maximum size 1-11/2" in required thickness to proper camber and grade including supplying and spreading 15 cft: screening & non plastic quarry fines filling depressions with stone metal after initial rolling including watering and compacting the same as to achieve 100% density as per modified AASHO specification. (Rate including providing & using Templates, screen, forms as directed). (Rate includes cost of materials T&P and carriage into site of work).			
	106049	Cft	10930.70	% Cft	11591898
5		<b>Ist coat</b>			
		Providing surface dressing 1st coat on new or existing surface with 30 lbs of bitumen of 80-100 penetration & 4 cft crush bajri of 3/8-3/4" gauge including cleaning to road surface rolling after each coat etc complete. Rate includes all cost of materials T&P and Carriage upto site of work.			
	212098	Sft	1668.70	% Sft	3539279
6		<b>1" thick Carpet.</b>			
		Providing 1 1/2 thick (Consolidated) primixed carpet in proper camber and grade including supply 15 cft Crush Bajri and 5 Cft hill sand of approved quality and gauge with 93 lbs of bitumen of 80-100 penetration including mixing in mechanical mixture in required proportion heating the material and cleaning to road surface. Rate including all cost of materials T&P and carriage upto site of work.			
	212098	Sft	4612.63	% Sft	9783296

Total Rs: 46137807

P.Tons (-) Rs. 1308128

G. Total Rs. 44829679/

Ded: Diff Cost of Bitumen

91.85 Tons

14242.00

Note:- The Quantities and Rates are Provisional and or Subjected to revision as per T.S by the

  
 CONTRACTOR

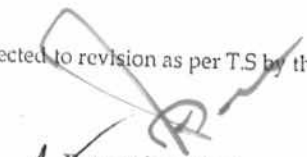
  
 Executive Engineer  
 Highway Division  
 Shaheed Benazir Abad

**SCHEDULE "B" RCC Pipe** *Bill of Quantities*

Name of Work:- Constt: of road from Nawabshah Sarhari road to Connect Nawabshah Varr road Via Haji Muhammad Bux Brohi, Allah Ditto Magsi, Haji Jan Muhammad Brohi & Ghulam Hyder Zardari UC Khadhar & Gupchani Taluka Sakrand & Daur mile 0/0-3/2.

Quantity	S.No	Item of Work	Rate	Unit	Amount
1		Providing & Fixing RCC Pipe 18" inch dia Coller of B Class Banding Fixing Positioning i/c cutting and filling i/c testing with waster head.			
320	Rft.		Rs. 412.00	P.Rft	Rs:131840/-
				Total	Rs:131840/-

Note:- The Quantities and Rates are Provisional and or Subjected to revision as per T.S by the competant authority.

*[Signature]*  
CONTRACTOR

*[Signature]*  
Executive Engineer  
Highway Division  
Shaheed Benazir Abad

3" Span RCC Slab Culvert.

Bill of Quantities

Name of Work: Constt: of road from Nawabshah Sarhari road to Connect Nawabshah Varr road Via Haji Muhammad Bux Brohi, Allah Ditto Magsi, Haji Jan Muhammad Brohi & Ghulam Hyder Zardari UC Khadhar & Gupchani Taluka Sakrand & Daur mile 0/0-3/2.

S.No:	Item	Unit	Calculation	Rate	Unit	Amount
1	Excavation in foundation of building and other structure i/c degbilin dressing refilling around the structure with excavated earth watering and rammin lead up to one chain and lift upto 5 feet (in ordinary soil)(s.I.No:18/P-4).					
	1600	Cft	@Rs: 3176.25	%0 Cft		5082
2	Cement concrete brick or stone ballast 1/1/2" gauge ratio 1:4:8					
	240	Cft	@Rs: 9416.28	% Cft		22599
3	Pacca Brick work in foundation and plinth in cement sand mortar ratio 1:4 (S.I.No:4/P-24)					
	372	Cft	@Rs: 12501.41	% Cft		46505
4	Cement concrete plain including placing compacting finishing and curring complete including screening and washing of stone aggregate without shuttering Ratio 1:2:4(S.I.No:5/P-18)					
	75	Cft	@Rs: 14429.25	% Cft		10822
5	Fabrication of mild steel reinforcement for cement concrete including cutting bending laying in position making joints and fastering including cost of bending wire also includes removal of rust from bars,					
	4.92	Cwt	@Rs: 4820.20	P.Cwt		23715
6	R.C.C work including all labour and material except the cost of steel refoement and its labour for binding and kinds of forms moulds lifting shuttering curring rendering and finishing the exposed surface includes sceening and washing of shingle R.C.C work in roof slab beam columns rafts lintels and other structure main bars in position complete in all respect ratio 1:2:4.					
	81	Cft	@Rs: 337.00	P.Cft		27297
7	Erection and removal of centering for RCC of CC plain (b) Vertical wood.					
	24	Sft	@Rs: 3127.41	% Sft		751
8	Cement plaster 1:3 upto 20" height 1/2" t (S.I.No:9/P-58)					
	200	Sft	@Rs: 2344.59	% Sft		4689
9	Brick on Edge Florng laid in 1:6 cement mortar over a bed 3/4" thick cement morot ratio 1:6 (SR.I.No:P-46)					
	70	Cft	@Rs: 5256.63	% P.Cft		3680
10	Supplying & Filling Sand Under Floor and plugging in walls (Sr.I.No:29 P-30)					
	513	Cft	@Rs: 1141.25	% P.Cft		5855

150995 x16  
Total Rs. 2415920/

Note:- The Quantities and Rates are Provisional and or Subjected to revision as per T.S by the competant authority.

  
CONTRACTOR

  
Executive Engineer  
Highway Division  
Shaheed Benazir Abad

## (INTEGRITY PACT)

DECLARATION OF FEES, COMMISSION AND BROKERAGE ETC  
PAYABLE BY CONTRACTORS

(FOR CONTRACTS WORTH RS. 10.00 MILLION OR MORE)

Contract No. 02 Dated 29-03-2016Contract Value: 46934809/Contract Title: Constt: of road from Nawabshah Sarhari road to Connect Nawabshah Varr road Via Haji Muhammad Bux Brohi, Allah Ditto Magsi, Haji Jan Muhammad Brohi & Ghulam Hyder Zardari UC Khadhar & Gupchani Taluka Sakrand & Daur mile 0/0-3/2.

**[Mr. Muhammad Akram Sahikh]** hereby declares that it has not obtained or induced the procurement of any contract, right, interest, privilege or other obligation or benefit from Government of Sindh (GoS) or any administrative subdivision or agency thereof or any other entity owned or controlled by it (GoS) through any corrupt business practice. Without limiting the generality of the foregoing,

**[Mr. Muhammad Akram Sahikh]** represents and warrants that it has fully declared the brokerage, commission, fees etc. paid or payable to anyone and not given or agreed to give and shall not give or agree to give to anyone within or outside Pakistan either directly or indirectly through any natural or juridical person, including its affiliate, agent, associate, broker, consultant, director, promoter, shareholder, sponsor or subsidiary, any commission, gratification, bribe, finder's fee or kickback, whether described as consultation fee or otherwise, with the object of obtaining or inducing the procurement of a contract, right, interest, privilege or other obligation or benefit in whatsoever form from, from Procuring Agency (PA) except that which has been expressly declared pursuant hereto.

**[Mr. Muhammad Akram Sahikh]** accepts full responsibility and strict liability that it has made and will make full disclosure of all agreements and arrangements with all persons in respect of or related to the transaction with PA and has not taken any action or will not take any action to circumvent the above declaration, representation or warranty.

**[Mr. Muhammad Akram Sahikh]** accepts full responsibility and strict liability for making any false declaration, not making full disclosure, misrepresenting facts or taking any action likely to defeat the purpose of this declaration, representation and warranty. It agrees that any contract, right, interest, privilege or other obligation or benefit obtained or procured as aforesaid shall, without prejudice to any other rights and remedies available to PA under any law, contract or other instrument, be voidable at the option of PA.

Notwithstanding any rights and remedies exercised by PA in this regard,

**[Mr. Muhammad Akram Sahikh]** agrees to indemnify PA for any loss or damage incurred by it on account of its corrupt business practices and further pay compensation to PA in an amount equivalent to ten time the sum of any commission, gratification, bribe, finder's fee or kickback given by [name of Contractor] as aforesaid for the purpose of obtaining or inducing the procurement of any contract, right, interest, privilege or other obligation or benefit in whatsoever form from PA.

EXECUTIVE ENGINEER  
Highway Division.....  
[Procuring Agency]

  
[Contractor]





# BID EVALUATION REPORT

1.	Name of Procuring Agency:	Executive Engineer Highway Division S.B.A.
2.	Tender Reference No:	E.E Highway TC/G-55/346, Dated 07-03-2016.
3.	Tender Description/Name of work/ Item:	Const: of road from Nawabshah Sarhari road to Connect Nawabshah Varr road Via Haji Muhammad Bux Brohi, Allah Ditto Magsi, Haji Jan Muhammad Brohi & Ghulam Hyder Zardari UC Khadhur & Cupchani Taluka Sakrand & Daur mile 0/0-3/2. A.D.P NO. 1171.
4.	Method of Procurement:	Single stage one Envelope Procedure.
5.	Tender Published:	Leading News paper Dawn English, Jang Urdu, Sobh Sindhi, Ibrat Sindh & others) SPPRA Website S.No.26875.
6.	Total Bid documents sold:	06 Nos
7.	Total Bids received:	06 Nos
8.	Technical Bid Opening date (if applicable):	N/A
9.	No. of Bid technically qualified (if applicable):	N/A
10.	Bid (s) Rejected:	05 Nos
11.	Financial Bid Opening date:	29-03-2016
12.	Bid Evaluation Report:	

S#	Name of Firm or Bidder	Cost offered by the Bidder	Ranking in terms of cost	Comparison with Estimated cost Rs. 47576000/	Reasons for acceptance or rejection	Remarks
0	1	2	3	4	5	6
1	Mr. Muhammad Akram Shaikh	46934809	1 <sup>st</sup> Lowest	1.35% Below	Lowest Bid	Accepted
2	M/S Muhammad Ramzan Brohi & Co:	46950581	2 <sup>nd</sup> Lowest	1.31% Below	Highest Bid	Rejected
3	M/S Khalil Engg: Works	46965288	3 <sup>rd</sup> Lowest	1.28% Below	Highest Bid	Rejected
4	M/S Abdul Ghaffar Memon	47383917	4 <sup>th</sup> Lowest	0.40% Below	Highest Bid	Rejected
5	M/S Crescent Engineering Works	47397225	5 <sup>th</sup> Lowest	0.38% Below	Highest Bid	Rejected
6	M/S Atta Muhammad Bughio	47410132	6 <sup>th</sup> Lowest	0.35% Below	Highest Bid	Rejected

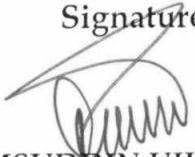
**Signatures of the Members of the Committee.**

  
**SHAMSUDDIN UJAN**  
 DIVISIONAL ACCOUNTS OFFICER  
 HIGHWAY DIVISION, SHAHEED BENAZIR ABAD  
 MEMBER OF PROCUREMENT COMMITTEE

  
**ILLAMUDDIN DAHRI**  
 ASSISTANT ENGINEER,  
 BUILDINGS DIVISION, SHAHEED BENAZIR ABAD  
 MEMBER OF PROCUREMENT COMMITTEE

  
**MUHAMMAD AYOUB SHAIKH**  
 EXECUTIVE ENGINEER  
 HIGHWAY DIVISION  
 SHAHEED BENAZIR ABAD  
 CHAIRMAN OF PROCUREMENT COMMITTEE





OFFICE OF THE  
**EXECUTIVE ENGINEER**  
**HIGHWAY DIVISION, SHAHEED BENAZIR ABAD.**

Address: Situated at near Kazi Ahmed road Nawabshah.

This Office NIT No, TC/G-55/346

Dated: 07-03-2016.

SUBJECT: PROCUREMENT COMMITTEE MEETING HELD ON 29-03-2016.

A meeting of the Procurement Committee was held in the office of Executive Engineer, Highway Division, Shaheed Benazir Abad, under the Chairmanship of Executive Engineer.

2. The below mentioned member of Committee attended the meeting to discuss the Bids invited for the Procurement of Works vide Executive Engineer, Highway Division, Shaheed Benazir Abad, letter No. TC/G-55/ 346, Dated: 07-03-2016 and subsequently hoisted on the website of Sindh Public Procurement Regulatory Authority Sr. No. 26875 and Information Technology Department Government of Sindh.

Following attend the meeting.

- 1 MR. SHAMSUDDIN UJJAN,  
DIVISIONAL ACCOUNTS OFFICER,  
HIGHWAY DIVISION, MEMBER  
SHAHEED BENAZIR ABAD.
2. MR. ILLAMUDDIN DAHRI,  
ASSISTANT ENGINEER,  
BUILDINGS DIVISION, MEMBER  
SHAHEED BENAZIR ABAD.

- 3 During the course of meeting following discussion were made by the Committee.
  - i. The Tender received back on dated 29-03-2016, at 1.00 pm & was Opened before the Procurement Committee in presence of representatives of participants,
  - ii. The methods of Bidding Documents observed as single envelope.
  - iii. The Tender was opened on 29-03-2016 before the Tender Opening Committee.

**SR. NO. 01. CONSTT: OF ROAD FROM NAWABSHAH SARHARI ROAD (BAKSHO JAMALI) TO VILLAGE AFZAL / MEHAR ALI BHANGWAR UC GUPCHANI TALUKA DAUR MILE 0/0-1/7. A.D.P NO. 1170.**

4. The Committee was informed that 07 Nos Bidders have purchased the Bidding Documents upto Dated: 28-03-2016 and 07 Nos have responded the Bids on Date: 29-03-2016 upto 1:00 pm in the office of Executive Engineer, Highway Division, Shaheed Benazir Abad.
5. During the opening of Tender received, following status was found.

S #	Name of Firms	Raking in Term of Cost	Remarks
01	M/S Khalil Engineering Works	1 <sup>st</sup> Lowest	Lowest
02	M/S Muhammad Ramzan Brohi & Co:	2 <sup>nd</sup> Lowest	Highest
03	M/S Atta Muhammad Bughio	3 <sup>rd</sup> Lowest	Highest
04	M/S Crescent Engineering Works	4 <sup>th</sup> lowest	Highest
05	M/S Abdul Ghaffar Memon	5 <sup>th</sup> lowest	Highest
06	Mr. Muhammad Yaqoob Arain	6 <sup>th</sup> lowest	Highest
07	M/S Muhammad Shahid & Co:	7 <sup>th</sup> lowest	Highest

**SR. NO. 02. CONSTT: OF ROAD FROM NAWABSHAH SARHARI ROAD TO CONNECT NAWABSHAH VARR ROAD VIA HAJI MUHAMMAD BUX BROHI, ALLAH DITTO MAGSI, HAJI JAN MUHAMMAD BROHI & GHULAM HYDER ZARDARI UC KHADHAR & GUPCHANI TALUKA SAKRAND & DAUR MILE 0/0-3/2 A.D.P NO.1171.**

4. The Committee was informed that 06 Nos Bidders have purchased the Bidding Documents upto Dated: 28-03-2016 and 06 Nos have responded the Bids on Date: 29-03-2016 upto 1:00 pm in the office of Executive Engineer, Highway Division, Shaheed Benazir Abad.
5. During the opening of Tender received, following status was found.

S #	Name of Firms	Raking in Term of Cost	Remarks
01	Mr. Muhammad Akram Shaikh	1 <sup>st</sup> Lowest	Lowest
02	M/S Muhammad Ramzan Brohi & Co:	2 <sup>nd</sup> Lowest	Highest
03	M/S Khalil Engineering Works	3 <sup>rd</sup> Lowest	Highest
04	M/S Abdul Ghaffar Memon	4 <sup>th</sup> lowest	Highest
05	M/S Crescent Engineering Works	5 <sup>th</sup> lowest	Highest
06	M/S Atta Muhammad Bughio	6 <sup>th</sup> lowest	Highest

**SR. NO. 03. CONSTT: OF ROAD FROM @ VILLAGE MUHAMMAD KHAN SETHAR TO OLD VILLAGE LAL BUX SHAHANI NEW VILLAGE MUHAMMAD ALAM SHAHANI TALUKA DAUR DISTRICT SHAHEED BENAZIR ABAD MILE 0/0-2/4 A.D.P NO. 1185.**

4. The Committee was informed that 06 Nos Bidders have purchased the Bidding Documents upto Dated: 28-03-2016 and 06 Nos have responded the Bids on Date: 29-03-2016 upto 1:00 pm in the office of Executive Engineer, Highway Division, Shaheed Benazir Abad.
5. During the opening of Tender received, following status was found.

S #	Name of Firms	Raking in Term of Cost	Remarks
01	M/S Atta Muhammad Bughio	1 <sup>st</sup> Lowest	Lowest
02	M/S Crescent Engineering Works	2 <sup>nd</sup> Lowest	Highest
03	M/S Abdul Ghaffar Memon	3 <sup>rd</sup> Lowest	Highest
04	M/S Muhammad Ramzan Brohi & Co:	4 <sup>th</sup> lowest	Highest
05	M/S Muhammad Shahid & Co:	5 <sup>th</sup> lowest	Highest
06	Mr. Muhammad Yaqoob Arain	6 <sup>th</sup> lowest	Highest

6. The Committee thoroughly scrutinized each case / Tender Document, by comparing earth matically and financially with sanctioned estimates / Bill of quantities and criteria for eligibility and minimum qualification as per Bidding Documents.
7. **Recommendation**  
After due deliberation / scrutiny of each Tender Document by the Committee, it was recommended that lowest evaluated responsive Bidder may be awarded the respective Tender.
8. **Decision**  
In view of Para No.7 of this report it is decided that Tenders are being awarded to above mentioned lowest responsive Bidders accordingly.

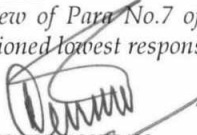
  
**SHAMSUDDIN UJAN**  
DIVISIONAL ACCOUNTS OFFICER  
HIGHWAY DIVISION, SHAHEED BENAZIR ABAD  
MEMBER OF PROCUREMENT COMMITTEE

  
**ILLAMUDDIN DAHRI**  
ASSISTANT ENGINEER,  
BUILDINGS DIVISION, SHAHEED BENAZIR ABAD  
MEMBER OF PROCUREMENT COMMITTEE









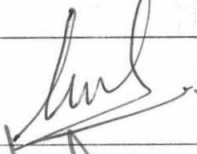

  
**MUHAMMAD AYOUB SHAIKH**  
EXECUTIVE ENGINEER  
HIGHWAY DIVISION  
SHAHEED BENAZIR ABAD  
CHAIRMAN OF PROCUREMENT COMMITTEE

# ATTENDANCE SHEET

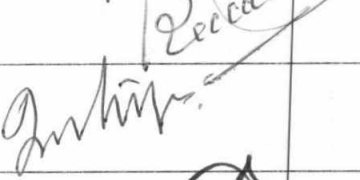
NIT NO. TC/G-55/346

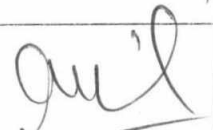
DATED: 07-03-2016

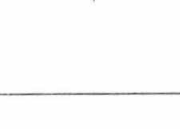
Bid Opened before me on 29-3-2016 since I have participated in Tenders & the Tender were Opened in my presence & the complete Tendering process was transparent & perfect competition was observed.

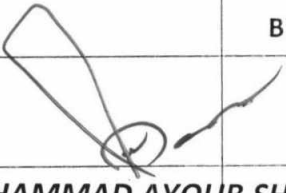
S.No.	Name of Contractor	Signature
(1)	Khalid Engineering works	
(2)	M/S Alta Muhammad Bakhsh M/S M. Ramzan Bashi	 
(3)	M/S. Mahesh YAKOUB	
(4)	M/S Muhammad Sherif & Co	
(5)	Abdul Ghaffar Memon	
(6)	Geesant Eng. Works	
(7)	Metro Eng. Works	
(8)	Mohd Akram Shaikh	
	 <b>SHAMSUDDIN UJAN</b> DIVISIONAL ACCOUNTS OFFICER HIGHWAY DIVISION, SHAHEED BENAZIR ABAD MEMBER OF PROCUREMENT COMMITTEE	 <b>ILLAMUDDIN DAHRI</b> ASSISTANT ENGINEER, BUILDINGS DIVISION, SHAHEED BENAZIR ABAD MEMBER OF PROCUREMENT COMMITTEE
	 <b>MUHAMMAD AYOUB SHAIKH</b> EXECUTIVE ENGINEER HIGHWAY DIVISION SHAHEED BENAZIR ABAD CHAIRMAN OF PROCUREMENT COMMITTEE	

**COMPERATIVE STATEMENT & FINANCIAL REVIEW.**

TC/G-55/346, Dated: 07-03-2016. Date of open: 29-03-2016  
 Date of issue: 28-03-2016

NAME OF WORK:- Constt: of road from Nawabshah Sarhari road to Connect Nawabshah Varr Road Via Haji Muhammad Bux Brohi Allah Ditto Magsi, Haji Jan Muhammad Brohi & Ghulam Hyder Zardari UC Khadhar & Gupchani Taluka Sakrand & Daur mile 0/0-3/2 A.D.P No. 1171.

Description.	Estimated cost.		M/S Muhammad Akram Shaikh Co: <u>I</u> Rate.	M/S Muhammad Ramzan Brohi & Co: <u>II</u> Rate.	M/S Khalil Engg: Works <u>III</u> Rate.
	Rate	Amount.			
<b>ROAD COMPONENT PART-I.</b>					
1.Amount of Sch: "B"	Rs.	46653249	Rs:	46653249	Rs:
2.Add: Diff: of Bricks.	Rs.	1722004	DCO Bitumen Rs:	1722004	DCO Bitumen Rs:
3. Ded:diff:cost of Bitumen (-)	Rs.	1722004	Total Rs:	44931245	Total Rs:
91.85 Tons at Rs. 18748.00 P.Tons	Rs:	44931245	Ded: 2.29% Below	1068359	Ded: 2.24% Below
	Total Rs:	43862886	Total Rs:	43876882	Total Rs:

2% Below Ceiling fixed by EDO, (-)	Rs.	933065	Rs:	131840	Rs:
C.E. Total:	Rs.	43998180	14.59% Above Rs:	19235	14.70% Above
R.C.C PIPE COMPONENT PART -II.	Rs:	131840	Total Rs:	151075	Total Rs:
1.Amount of Sch: "B"	Rs:	131840	Rs:	131840	Rs:
2.Add: 15% Above	Rs:	19776	14.65% Above Rs:	19315	14.70% Above
	Total Rs:	151616	Total Rs:	151155	Total Rs:

MASONARY STRUCTURE	Rs:	150995	Rs:	150995	Rs:
COMPONENT PART -III.	Rs:	31862	20.97% Above Rs.	31664	21.19% Above
1.Amount of Sch: "B"	Rs:	31862	Rs:	182659 x16	Rs:
2.Cartage of Material	Rs:	2372	G.Total: Rs:	46950581	G.Total Rs:
3. Add 10% above on item No: 5 (+)	Rs:	185229 x16	Rs:	2922544	Rs:
Escalation of Steel	Rs:	2963664	G.Total: Rs:	46934809	G.Total Rs:
	G.Total: Rs:	47113460	Rs:	2920848	Rs:
			G.Total: Rs:	46934809	G.Total Rs:

  
 ILLAMUDDIN DAHRI  
 ASSISTANT ENGINEER  
 BUILDINGS DIVISION, SHAHEED  
 CHAIRMAN OF PROCUREMENT

  
 MUHAMMAD AYOUB SHAIKH  
 EXECUTIVE ENGINEER,  
 HIGHWAY DIVISION  
 SHAHEED BENAZIR ABAD  
 CHAIRMAN OF PROCUREMENT COMMITTEE

  
 SHAMSUDDIN IJJAN  
 DIVISIONAL ACCOUNTS OFFICER  
 HIGHWAY DIVISION, SHAHEED BENAZIR ABAD  
 MEMBER OF PROCUREMENT COMMITTEE

**COMPERATIVE STATEMENT.**

TC/G-55/346, Dated: 07-03-2016.

Date of open: 29-03-2016

Date of issue: 28-03-2016

NAME OF WORK:- Constt: of road from Nawabshah Sarhari road to Connect Nawabshah Varr Road Via Haji Muhammad Bux Brohi Allah Ditto Magsi, Haji Jan Muhammad Brohi & Ghulam Hyder Zardari UC Khadhhar & Gupchani Taluka Sakrand & Daur mile 0/0-3/2 A.D.P No. 1171.

Description.	Estimated cost.		M/S Abdul Ghaffar Memon		M/S Crescent Engg: Works		M/S Atta Muhammad Bughio	
	Rs.		Rate.	Amount.	Rate.	Amount.	Rate.	Amount.
<b>ROAD COMPONENT PART-I.</b>								
1.Amount of Sch: "B"	Rs.		Rs:	46653249	Rs:	46653249	Rs:	46653249
2.Add: Diff: of Bricks.			DCO.Bitumer Rs:	1308128	DCO Bitumen Rs:	1308128	DCO Bitumen Rs:	1308128
3.Add:diff:cost of Bitumen (-)	Rs.		Total Rs:	45345121	Total Rs:	45345121	Total Rs:	45345121
91.85 Tons at Rs. 14242.00 P.Tons	Rs:							
			Ded: 2.22% Below	1035702	Ded: 2.20% Below	1026371	Ded: 2.18% Below	1017041
2% Below Ceiling fixed by EDO,	Rs.		Total Rs:	44309419	Total Rs:	44318750	Total Rs:	44328080
C.E.	Rs.							
<b>R.C.C PIPE COMPONENT PART -II.</b>								
1.Amount of Sch: "B"	Rs:		Rs:	131840	Rs:	131840	Rs:	131840
2.Add: 15% Above	Rs:		Rs:	19394	Rs:	19499	Rs:	19460
			Total Rs:	151234	Total Rs:	151339	Total Rs:	151300
<b>MASONARY STRUCTURE</b>								
<b>COMPONENT PART -III.</b>								
1.Amount of Sch: "B"	Rs:		Rs:	150995	Rs:	150995	Rs:	150995
2.Cartage of Material	Rs:		Rs:	31709	Rs:	31951	Rs:	32177
3. Add 10% above on item No: 5 (+)	Rs:		Rs:	182704 x16	Rs:	182946 x16	Rs:	183172 X16
Escalation of Steel	Rs.							
			G.Total: Rs:	47383917	G.Total: Rs:	47397225	G.Total Rs:	47410132

Certified that the entries have been correctly incorporated in the comparative Statement as per rates and amount in the individual Schedule "B" (BOQ).

The lowest offer of Mr. Muhammad Akram Shaikh Comes to 2.29% Below for Part I, 14.59% Above for Part II & 20.90% Above for Part III, The estimate rate shown in schedule "B" For Part I, for Part II & Part III.

  
**SHAMSUDDIN**  
 DIVISIONAL ACCOUNTS OFFICER  
 HIGHWAY DIVISION, SHAHEED BENAZIR ABAD  
 MEMBER OF PROCUREMENT COMMITTEE

  
**MUHAMMAD AYOUB SHAIKH**  
 EXECUTIVE ENGINEER,  
 HIGHWAY DIVISION  
 SHAHEED BENAZIR ABAD  
 CHAIRMAN OF PROCUREMENT COMMITTEE

  
**ILLAMUDDIN DAHRI**  
 ASSISTANT ENGINEER  
 BUILDINGS DIVISION, SHAHEED BENAZIR ABAD  
 CHAIRMAN OF PROCUREMENT COMMITTEE





## BIDDERS' ELEGIBILITY/QUALIFICATION REPORT

*Eligibility / Qualification Criteria:*

**Agency:- M/S Khalil Engineering Works**

S No.	Eligibility/Qualification Criteria	Yes	No
01	Full name permanent address, mobile No. Fax No, E-Mail Address & the organizational; structure.	Yes	
02	Bio Data of Technical Staff Employees & to be made available for working on the project.	Yes	
03	List of scope & approximate cost of works in hand.	Yes	
04	Financial stability certificate issued by Scheduled Bank.	Yes	
05	Affidavit with be undertaking that the information / particulars provided by him is true & correct.	Yes	
06	Registration Income Tax Department along with NTN.	Yes	
07	The intending Agency / Firms should have Register / Approved with Sindh Revenue Board.	Yes	
08	The intending Agency / Firms have to submit the Affidavit to the effect that his Firm / Agency is not involved in any litigation & left abandoned the work in any Government Department & not black listed.	Yes	
09	List of Machinery & equipments available with documentary evidence of its ownership.	Yes	
10	Documentary evidence of works executed, works in progress & certificate of satisfactory completions of work by the Employers.	Yes	
11	Registration with Pakistan Engineering Council in the relevant field of specialization of work (CE 01) & to the Extent of the Tender amount of each work for the year 2016.	Yes	
12	The earnest money specified would be pledged in the name of Executive Engineer, Highway Division, Shaheed Benazir Abad in the shape of Call Deposit from any Scheduled Bank & must be attached with Bid Documents; otherwise it will not be entertained.	Yes	
13	If Firm / Partner involved in partnership deed, such details & power of attorney will be submitted on affidavit by the proprietor.	Yes	

  
**SHAMSUDDIN UJJAN**  
DIVISIONAL ACCOUNTS OFFICER  
HIGHWAY DIVISION, SHAHEED BENAZIR ABAD  
MEMBER OF PROCUREMENT COMMITTEE

  
**ILLAMUDDIN DAHRI**  
ASSISTANT ENGINEER,  
BUILDINGS DIVISION, SHAHEED BENAZIR ABAD  
MEMBER OF PROCUREMENT COMMITTEE

  
**MUHAMMAD AYOUB SHAIKH**  
EXECUTIVE ENGINEER  
HIGHWAY DIVISION  
SHAHEED BENAZIR ABAD  
CHAIRMAN OF PROCUREMENT COMMITTEE

## BIDDERS' ELEGIBILITY / QUALIFICATION REPORT

Eligibility / Qualification Criteria:

Agency:- **Engr. Muhammad Akram Shaikh**

S No.	Eligibility / Qualification Criteria	Yes	No
01	Full name permanent address, mobile No. Fax No, E-Mail Address & the organizational; structure.	Yes	
02	Bio Data of Technical Staff Employees & to be made available for working on the project.	Yes	
03	List of scope & approximate cost of works in hand.	Yes	
04	Financial stability certificate issued by Scheduled Bank.	Yes	
05	Affidavit with be undertaking that the information / particulars provided by him is true & correct.	Yes	
06	Registration Income Tax Department along with NTN.	Yes	
07	The intending Agency / Firms should have Register / Approved with Sindh Revenue Board.	Yes	
08	The intending Agency / Firms have to submit the Affidavit to the effect that his Firm / Agency is not involved in any litigation & left abandoned the work in any Government Department & not black listed.	Yes	
09	List of Machinery & equipments available with documentary evidence of its ownership.	Yes	
10	Documentary evidence of works executed, works in progress & certificate of satisfactory completions of work by the Employers.	Yes	
11	Registration with Pakistan Engineering Council in the relevant field of specialization of work (CE 01) & to the Extent of the Tender amount of each work for the year 2016.	Yes	
12	The earnest money specified would be pledged in the name of Executive Engineer, Highway Division, Shaheed Benazir Abad in the shape of Call Deposit from any Scheduled Bank & must be attached with Bid Documents; otherwise it will not be entertained.	Yes	
13	If Firm / Partner involved in partnership deed, such details & power of attorney will be submitted on affidavit by the proprietor.	Yes	

  
**SHAMSUDDIN UJJAN**  
DIVISIONAL ACCOUNTS OFFICER  
HIGHWAY DIVISION, SHAHEED BENAZIR ABAD  
MEMBER OF PROCUREMENT COMMITTEE

  
**ILLAMUDDIN DAHRI**  
ASSISTANT ENGINEER,  
BUILDINGS DIVISION, SHAHEED BENAZIR ABAD  
MEMBER OF PROCUREMENT COMMITTEE

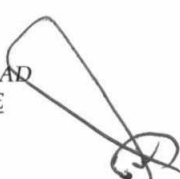
  
**MUHAMMAD AYOUB SHAIKH**  
EXECUTIVE ENGINEER  
HIGHWAY DIVISION  
SHAHEED BENAZIR ABAD  
CHAIRMAN OF PROCUREMENT COMMITTEE





## BIDDERS' ELEGIBILITY / QUALIFICATION REPORT

*Eligibility / Qualification Criteria:*

**Agency:- M/S Atta Muhammad Bughio**

S No.	Eligibility/Qualification Criteria	Yes	No
01	Full name permanent address, mobile No. Fax No, E-Mail Address & the organizational; structure.	Yes	
02	Bio Data of Technical Staff Employees & to be made available for working on the project.	Yes	
03	List of scope & approximate cost of works in hand.	Yes	
04	Financial stability certificate issued by Scheduled Bank.	Yes	
05	Affidavit with be undertaking that the information / particulars provided by him is true & correct.	Yes	
06	Registration Income Tax Department along with NTN.	Yes	
07	The intending Agency / Firms should have Register / Approved with Sindh Revenue Board.	Yes	
08	The intending Agency / Firms have to submit the Affidavit to the effect that his Firm / Agency is not involved in any litigation & left abandoned the work in any Government Department & not black listed.	Yes	
09	List of Machinery & equipments available with documentary evidence of its ownership.	Yes	
10	Documentary evidence of works executed, works in progress & certificate of satisfactory completions of work by the Employers.	Yes	
11	Registration with Pakistan Engineering Council in the relevant field of specialization of work (CE 01) & to the Extent of the Tender amount of each work for the year 2016.	Yes	
12	The earnest money specified would be pledged in the name of Executive Engineer, Highway Division, Shaheed Benazir Abad in the shape of Call Deposit from any Scheduled Bank & must be attached with Bid Documents; otherwise it will not be entertained.	Yes	
13	If Firm / Partner involved in partnership deed, such details & power of attorney will be submitted on affidavit by the proprietor.	Yes	

  
**SHAMSUDDIN UJJAN**  
DIVISIONAL ACCOUNTS OFFICER  
HIGHWAY DIVISION, SHAHEED BENAZIR ABAD  
MEMBER OF PROCUREMENT COMMITTEE

  
**ILLAMUDDIN DAHRI**  
ASSISTANT ENGINEER,  
BUILDINGS DIVISION, SHAHEED BENAZIR ABAD  
MEMBER OF PROCUREMENT COMMITTEE

  
**MUHAMMAD AYOUB SHAIKH**  
EXECUTIVE ENGINEER  
HIGHWAY DIVISION  
SHAHEED BENAZIR ABAD  
CHAIRMAN OF PROCUREMENT COMMITTEE

## BIDDERS' ELEGIBILITY / QUALIFICATION REPORT

*Eligibility / Qualification Criteria:*

**Agency:- M/S Muhammad Ramzan Brohi & Co:**

S No.	Eligibility / Qualification Criteria	Yes	No
01	Full name permanent address, mobile No. Fax No, E-Mail Address & the organizational; structure.	Yes	
02	Bio Data of Technical Staff Employees & to be made available for working on the project.	Yes	
03	List of scope & approximate cost of works in hand.	Yes	
04	Financial stability certificate issued by Scheduled Bank.		No
05	Affidavit with be undertaking that the information / particulars provided by him is true & correct.		No
06	Registration Income Tax Department along with NTN.	Yes	
07	The intending Agency / Firms should have Register / Approved with Sindh Revenue Board.	Yes	
08	The intending Agency / Firms have to submit the Affidavit to the effect that his Firm / Agency is not involved in any litigation & left abandoned the work in any Government Department & not black listed.		No
09	List of Machinery & equipments available with documentary evidence of its ownership.	Yes	
10	Documentary evidence of works executed, works in progress & certificate of satisfactory completions of work by the Employers.	Yes	
11	Registration with Pakistan Engineering Council in the relevant field of specialization of work (CE 01) & to the Extent of the Tender amount of each work for the year 2016.	Yes	
12	The earnest money specified would be pledged in the name of Executive Engineer, Highway Division, Shaheed Benazir Abad in the shape of Call Deposit from any Scheduled Bank & must be attached with Bid Documents; otherwise it will not be entertained.	Yes	
13	If Firm / Partner involved in partnership deed, such details & power of attorney will be submitted on affidavit by the proprietor.		No

  
**SHAMSUDDIN UJJAN**  
DIVISIONAL ACCOUNTS OFFICER  
HIGHWAY DIVISION, SHAHEED BENAZIR ABAD  
MEMBER OF PROCUREMENT COMMITTEE

  
**ILLAMUDDIN DAHRI**  
ASSISTANT ENGINEER,  
BUILDINGS DIVISION, SHAHEED BENAZIR ABAD  
MEMBER OF PROCUREMENT COMMITTEE

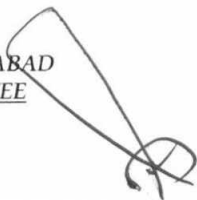
  
**MUHAMMAD AYOUB SHAIKH**  
EXECUTIVE ENGINEER  
HIGHWAY DIVISION  
SHAHEED BENAZIR ABAD  
CHAIRMAN OF PROCUREMENT COMMITTEE

## BIDDERS' ELEGIBILITY / QUALIFICATION REPORT

*Eligibility / Qualification Criteria:*

**Agency:- M/S Crescent Engg: Works**

S No.	Eligibility / Qualification Criteria	Yes	No
01	Full name permanent address, mobile No. Fax No, E-Mail Address & the organizational; structure.	Yes	
02	Bio Data of Technical Staff Employees & to be made available for working on the project.		No
03	List of scope & approximate cost of works in hand.	Yes	
04	Financial stability certificate issued by Scheduled Bank.		No
05	Affidavit with be undertaking that the information / particulars provided by him is true & correct.	Yes	
06	Registration Income Tax Department along with NTN.		No
07	The intending Agency / Firms should have Register / Approved with Sindh Revenue Board.	Yes	
08	The intending Agency / Firms have to submit the Affidavit to the effect that his Firm / Agency is not involved in any litigation & left abandoned the work in any Government Department & not black listed.	Yes	
09	List of Machinery & equipments available with documentary evidence of its ownership.		No
10	Documentary evidence of works executed, works in progress & certificate of satisfactory completions of work by the Employers.	Yes	
11	Registration with Pakistan Engineering Council in the relevant field of specialization of work (CE 01) & to the Extent of the Tender amount of each work for the year 2016.	Yes	
12	The earnest money specified would be pledged in the name of Executive Engineer, Highway Division, Shaheed Benazir Abad in the shape of Call Deposit from any Scheduled Bank & must be attached with Bid Documents; otherwise it will not be entertained.	Yes	
13	If Firm / Partner involved in partnership deed, such details & power of attorney will be submitted on affidavit by the proprietor.		No

  
**SHAMSUDDIN UJAN**  
DIVISIONAL ACCOUNTS OFFICER  
HIGHWAY DIVISION, SHAHEED BENAZIR ABAD  
MEMBER OF PROCUREMENT COMMITTEE

  
**ILLAMUDDIN DAHRI**  
ASSISTANT ENGINEER,  
BUILDINGS DIVISION, SHAHEED BENAZIR ABAD  
MEMBER OF PROCUREMENT COMMITTEE

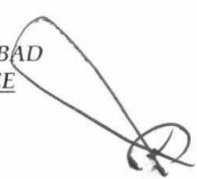
  
**MUHAMMAD AYOUB SHAIKH**  
EXECUTIVE ENGINEER  
HIGHWAY DIVISION  
SHAHEED BENAZIR ABAD  
CHAIRMAN OF PROCUREMENT COMMITTEE

## BIDDERS' ELEGIBILITY / QUALIFICATION REPORT

*Eligibility / Qualification Criteria:*

**Agency:- M/S Abdul Ghaffar Memon**

S No.	Eligibility / Qualification Criteria	Yes	No
01	Full name permanent address, mobile No. Fax No, E-Mail Address & the organizational; structure.	Yes	
02	Bio Data of Technical Staff Employees & to be made available for working on the project.	Yes	
03	List of scope & approximate cost of works in hand.	Yes	
04	Financial stability certificate issued by Scheduled Bank.	Yes	
05	Affidavit with be undertaking that the information / particulars provided by him is true & correct.	Yes	
06	Registration Income Tax Department along with NTN.	Yes	
07	The intending Agency / Firms should have Register / Approved with Sindh Revenue Board.	Yes	
08	The intending Agency / Firms have to submit the Affidavit to the effect that his Firm / Agency is not involved in any litigation & left abandoned the work in any Government Department & not black listed.	Yes	
09	List of Machinery & equipments available with documentary evidence of its ownership.		No
10	Documentary evidence of works executed, works in progress & certificate of satisfactory completions of work by the Employers.	Yes	
11	Registration with Pakistan Engineering Council in the relevant field of specialization of work (CE 01) & to the extent of the Tender amount of each work for the year 2016.		No
12	The earnest money specified would be pledged in the name of Executive Engineer, Highway Division, Shaheed Benazir Abad in the shape of Call Deposit from any Scheduled Bank & must be attached with Bid Documents; otherwise it will not be entertained.	Yes	
13	If Firm / Partner involved in partnership deed, such details & power of attorney will be submitted on affidavit by the proprietor.	Yes	

  
**SHAMSUDDIN UJJAN**  
DIVISIONAL ACCOUNTS OFFICER  
HIGHWAY DIVISION, SHAHEED BENAZIR ABAD  
MEMBER OF PROCUREMENT COMMITTEE

  
**ILLAMUDDIN DAHRI**  
ASSISTANT ENGINEER,  
BUILDINGS DIVISION, SHAHEED BENAZIR ABAD  
MEMBER OF PROCUREMENT COMMITTEE

  
**MUHAMMAD AYOUB SHAIKH**  
EXECUTIVE ENGINEER  
HIGHWAY DIVISION  
SHAHEED BENAZIR ABAD  
CHAIRMAN OF PROCUREMENT COMMITTEE

## BIDDERS' ELEGIBILITY / QUALIFICATION REPORT

*Eligibility / Qualification Criteria:*

**Agency:- Mr. Muhammad Yaqoob Arain**

S No.	Eligibility / Qualification Criteria	Yes	No
01	Full name permanent address, mobile No. Fax No, E-Mail Address & the organizational; structure.	Yes	
02	Bio Data of Technical Staff Employees & to be made available for working on the project.		No
03	List of scope & approximate cost of works in hand.		No
04	Financial stability certificate issued by Scheduled Bank.		No
05	Affidavit with be undertaking that the information / particulars provided by him is true & correct.	Yes	
06	Registration Income Tax Department along with NTN.	Yes	
07	The intending Agency / Firms should have Register / Approved with Sindh Revenue Board.	Yes	
08	The intending Agency / Firms have to submit the Affidavit to the effect that his Firm / Agency is not involved in any litigation & left abandoned the work in any Government Department & not black listed.	Yes	
09	List of Machinery & equipments available with documentary evidence of its ownership.		No
10	Documentary evidence of works executed, works in progress & certificate of satisfactory completions of work by the Employers.		No
11	Registration with Pakistan Engineering Council in the relevant field of specialization of work (CE 01) & to the Extent of the Tender amount of each work for the year 2016.		No
12	The earnest money specified would be pledged in the name of Executive Engineer, Highway Division, Shaheed Benazir Abad in the shape of Call Deposit from any Scheduled Bank & must be attached with Bid Documents; otherwise it will not be entertained.	Yes	
13	If Firm / Partner involved in partnership deed, such details & power of attorney will be submitted on affidavit by the proprietor.		No

  
**SHAMSUDDIN UJJAN**  
DIVISIONAL ACCOUNTS OFFICER  
HIGHWAY DIVISION, SHAHEED BENAZIR ABAD  
MEMBER OF PROCUREMENT COMMITTEE

  
**ILLAMUDDIN DAHRI**  
ASSISTANT ENGINEER,  
BUILDINGS DIVISION, SHAHEED BENAZIR ABAD  
MEMBER OF PROCUREMENT COMMITTEE

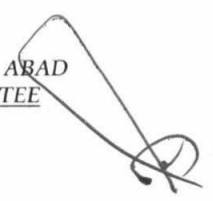
  
**MUHAMMAD AYOUB SHAIKH**  
EXECUTIVE ENGINEER  
HIGHWAY DIVISION  
SHAHEED BENAZIR ABAD  
CHAIRMAN OF PROCUREMENT COMMITTEE

## BIDDERS' ELEGIBILITY / QUALIFICATION REPORT

Eligibility / Qualification Criteria:

Agency:- M/S Muhammad Shahid & Co:

S No.	Eligibility / Qualification Criteria	Yes	No
01	Full name permanent address, mobile No. Fax No, E-Mail Address & the organizational; structure.	Yes	
02	Bio Data of Technical Staff Employees & to be made available for working on the project.		No
03	List of scope & approximate cost of works in hand.		No
04	Financial stability certificate issued by Scheduled Bank.		No
05	Affidavit with be undertaking that the information / particulars provided by him is true & correct.	Yes	
06	Registration Income Tax Department along with NTN.	Yes	
07	The intending Agency / Firms should have Register / Approved with Sindh Revenue Board.	Yes	
08	The intending Agency / Firms have to submit the Affidavit to the effect that his Firm / Agency is not involved in any litigation & left abandoned the work in any Government Department & not black listed.	Yes	
09	List of Machinery & equipments available with documentary evidence of its ownership.		No
10	Documentary evidence of works executed, works in progress & certificate of satisfactory completions of work by the Employers.		No
11	Registration with Pakistan Engineering Council in the relevant field of specialization of work (CE 01) & to the Extent of the Tender amount of each work for the year 2016.		No
12	The earnest money specified would be pledged in the name of Executive Engineer, Highway Division, Shaheed Benazir Abad in the shape of Call Deposit from any Scheduled Bank & must be attached with Bid Documents; otherwise it will not be entertained.	Yes	
13	If Firm / Partner involved in partnership deed, such details & power of attorney will be submitted on affidavit by the proprietor.		No

  
SHAMSUDDIN UJAN  
DIVISIONAL ACCOUNTS OFFICER  
HIGHWAY DIVISION, SHAHEED BENAZIR ABAD  
MEMBER OF PROCUREMENT COMMITTEE

  
ILLAMUDDIN DAHRI  
ASSISTANT ENGINEER,  
BUILDINGS DIVISION, SHAHEED BENAZIR ABAD  
MEMBER OF PROCUREMENT COMMITTEE

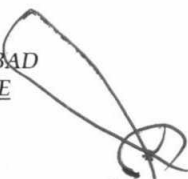
  
MUHAMMAD AYOUB SHAIKH  
EXECUTIVE ENGINEER  
HIGHWAY DIVISION  
SHAHEED BENAZIR ABAD  
CHAIRMAN OF PROCUREMENT COMMITTEE





OFFICE OF THE  
**EXECUTIVE ENGINEER**  
HIGHWAY DIVISION, SHAHEED BENAZIRABAD.

No: TC/G-55/ 516 S.B.A Dated. 18/4 /2016

Ph: 0244-9370133  
Fax: 0244-366648

To,

The Director (A&F),  
Sindh Public Procurement Regulatory Authority,  
Block No. 8 Sindh Secretariat A-4 Court Road,  
KARACHI SINDH.

Subject: - NIT NO. TC/G-55/346, DATED: 07-03-2016, SPPRA Sr. No. 26875.

The following Documents of NIT No. 346, Dated: 07-03-2016 are enclosed herewith,  
which may kindly be placed at SPPRA Website. SM: work ① and ③

D.A/As above

01. Bid Evaluation Report Original.
02. Minutes of the Bid Opening Meeting.
03. Attendance Sheet.
04. Comprative Statement Original.
05. Bidders Qualification Report Original.
06. News Papers.

D.A/AS ABOVE

  
EXECUTIVE ENGINEER  
HIGHWAY DIVISION  
SHAHEED BENAZIR ABAD

SPPRA VISITING DIARY  
NO: 963  
DATED: 19-04-16

# BID EVALUATION REPORT

1.	Name of Procuring Agency:	Executive Engineer Highway Division S.B.A.
2.	Tender Reference No:	E.E Highway TC/G-55/346, Dated 07-03-2016.
3.	Tender Description/Name of work/ Item:	Constt: of road from @ Village Muhammad Khan Sethar to Old Village Lal Bux Shahani New village Muhammad Alam Shahani Taluka Daur District Shaheed Benazir Abad mile 0/0-2/4 A.D.P NO. 1185.
4.	Method of Procurement:	Single stage one Envelope Procedure.
5.	Tender Published:	Leading News paper Dawn English, Jang Urdu, Sobh Sindhi, Ibrat Sindhi & others) SNo.26875.
6.	Total Bid documents sold:	06 Nos
7.	Total Bids received:	06 Nos
8.	Technical Bid Opening date (if applicable):	N/A
9.	No. of Bid technically qualified (if applicable):	N/A
10.	Bid (s) Rejected:	05 Nos
11.	Financial Bid Opening date:	29-03-2016
12.	Bid Evaluation Report:	

S#	Name of Firm or Bidder	Cost offered by the Bidder	Ranking in terms of cost	Comparison with Estimated cost Rs. 36.746	Reasons for acceptance or rejection	Remarks
0	1	2	3	4	5	6
1	M/S Atta Muhammad Bughio	36279471	1 <sup>st</sup> Lowest	1.27% Below	Lowest Bid	Accepted
2	M/S Crescent Engineering Works	36292847	2 <sup>nd</sup> Lowest	1.23% Below	Highest Bid	Rejected
3	M/S Abdul Ghaffar Memon	36301933	3 <sup>rd</sup> Lowest	1.21% Below	Highest Bid	Rejected
4	M/S Muhammad Ramzan Brohii & Co:	36316667	4 <sup>th</sup> Lowest	1.17% Below	Highest Bid	Rejected
5	M/S Muhammad Shahid & Co:	36328074	5 <sup>th</sup> Lowest	1.14% Below	Highest Bid	Rejected
6	Mr. Muhammad Yaqoob Arain	36339058	6 <sup>th</sup> Lowest	1.11% Below	Highest Bid	Rejected

## Signatures of the Members of the Committee

  
**SHAMSUDDIN UJJAN**  
 DIVISIONAL ACCOUNTS OFFICER  
 HIGHWAY DIVISION, SHAHEED BENAZIR ABAD  
 MEMBER OF PROCUREMENT COMMITTEE

  
**ILMUDDIN DAHRI**  
 ASSISTANT ENGINEER,  
 BUILDINGS DIVISION, SHAHEED BENAZIR ABAD  
 MEMBER OF PROCUREMENT COMMITTEE

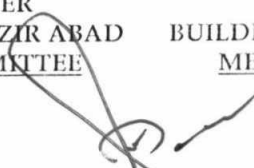
  
**MUHAMMAD AYOUB SHAIKH**  
 EXECUTIVE ENGINEER  
 HIGHWAY DIVISION  
 SHAHEED BENAZIR ABAD  
 CHAIRMAN OF PROCUREMENT COMMITTEE

# COMPERATIVE STATEMENT OF QUOTED RATES

(District Coordination Officer Shaheed Benazir Abad Notification No:PS/DCO/SBA/89, dated.01.07.2010)

Name of Work:- Constt: of road from @ Village Muhammad Khan Sethar to Old Village Lal Bux Shahani New village Muhammad Alam Shahani Taluka Daur District Shaheed Benazir Abad mile 0/0-2/4 A.D.P NO. 1185.

Tender Reference No. NIT No. 346 Dated: 07-03-2016.

Method of Procurement: Single Stage One Envelope Procedure.

Tender Published: Published in Dawn English, Jang Urdu, Sobh Sindhi, Ibrat Sindhi. SPPRA Website SNo. 26875.

Sr. No	Name of Contractor.		Rate Quoted.		
			Part-I, (Road component).	Part-II, (RCC Pipe Component).	Part-III, (Masonry Structure component).
01	M/s Atta Muhammad Bughio	Part (A)	3.76% Above	14.50% Above	20.70% Above
		Part (B)	2.26% Below	14.60% Above	20.72% Above
		Part (C)	3.76% Above	14.55% Above	20.68% Above
02	M/s Crescent Engg. Works.	Part (A)	3.80% Above	14.60% Above	20.75% Above
		Part (B)	2.24% Below	14.55% Above	20.75% Above
		Part (C)	3.80% Above	14.60% Above	20.75% Above
03	M/s Abdul Chaffar Memon.	Part (A)	3.84% Above	14.60% Above	20.79% Above
		Part (B)	2.21% Below	14.66% Above	20.79% Above
		Part (C)	3.80% Above	14.65% Above	20.79% Above
04	M/s Muhammad Ramzan Brohi S Co:	Part (A)	3.87% Above	14.70% Above	20.82% Above
		Part (B)	2.18% Below	14.72% Above	20.82% Above
		Part (C)	3.86% Above	14.72% Above	20.85% Above
05	M/s Muhammad Shahid S Co:	Part (A)	3.90% Above	14.73% Above	20.86% Above
		Part (B)	2.16% Below	14.73% Above	20.83% Above
		Part (C)	3.90% Above	14.73% Above	20.85% Above
06	M/s, Mohammad Yaqoob Arain	Part (A)	3.93% Above	14.73% Above	20.90% Above
		Part (B)	2.15% Below	14.73% Above	20.90% Above
		Part (C)	3.94% Above	14.75% Above	20.90% Above
07		Part (A)			
		Part (B)			
		Part (C)			
08		Part (A)			
		Part (B)			
		Part (C)			

Certified that the Tender have been opened before us by Executive Engineer Highway Division Shaheed Benazir Abad.

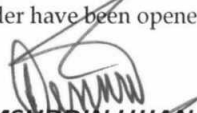
  
**SHAMSUDDIN UJAN**  
DIVISIONAL ACCOUNTS OFFICER  
HIGHWAY DIVISION, SHAHEED BENAZIR ABAD  
MEMBER OF PROCUREMENT COMMITTEE

  
**ILLAMUDDIN DAHRI**  
ASSISTANT ENGINEER,  
BUILDINGS DIVISION, SHAHEED BENAZIR ABAD  
MEMBER OF PROCUREMENT COMMITTEE

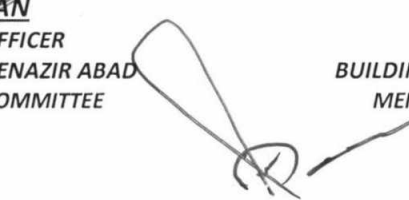
  
**MUHAMMAD AYOUB SHAIKH**  
EXECUTIVE ENGINEER  
HIGHWAY DIVISION  
SHAHEED BENAZIR ABAD  
CHAIRMAN OF PROCUREMENT COMMITTEE

# BID EVALUATION REPORT

1.	Name of Procuring Agency:	Executive Engineer Highway Division S.B.A.
2.	Tender Reference No:	E.E Highway TC/G-55/346, Dated 07-03-2016.
3.	Tender Description/Name of work/ Item:	Constt: of road from Nawabshah Sarhari road (Bakhsho Jamali) to village Afzal / Mehar Ali Bhangwar UC Gupchani Taluka Daur mile 0/0-1/7. A.D.P NO. 1170.
4.	Method of Procurement:	Single stage one Envelope Procedure.
5.	Tender Published:	Leading News paper Dawn English, Jang Urdu, Sobh Sindhi, Ibrat Sindhi & others) SNo.26875.
6.	Total Bid documents sold:	07 Nos
7.	Total Bids received:	07 Nos
8.	Technical Bid Opening date (if applicable):	N/A
9.	No. of Bid technically qualified (if applicable):	N/A
10.	Bid (s) Rejected:	06 Nos
11.	Financial Bid Opening date:	29-03-2016
12.	Bid Evaluation Report:	

S#	Name of Firm or Bidder	Cost offered by the Bidder	Ranking in terms of cost	Comparison with Estimated Cost Rs. 25.003	Reasons for acceptance or rejection	Remarks
0	1	2	3	4	5	6
1	M/S Khalil Engg: Works	24683022	1 <sup>st</sup> Lowest	1.28% Below	Lowest Bid	Accepted
2	M/S Muhammad Ramzan Brohi & Co:	24695260	2 <sup>nd</sup> Lowest	1.23% Below	Highest Bid	Rejected
3	M/S Atta Muhammad Bughio	24701200	3 <sup>rd</sup> Lowest	1.21% Below	Highest Bid	Rejected
4	M/S Crescent Engg: Works	24704532	4 <sup>th</sup> Lowest	1.19% Below	Highest Bid	Rejected
5	M/S Abdul Ghaffar Memon	24709943	5 <sup>th</sup> Lowest	1.17% Below	Highest Bid	Rejected
6	Mr. Muhammad Yaqoob Arain	24712014	6 <sup>th</sup> Lowest	1.16% Below	Highest Bid	Rejected
7	M/S Muhammad Shahid & Co:	24718350	7 <sup>th</sup> Lowest	1.14% Below	Highest Bid	Rejected

~~Signatures of the Members of the Committee~~

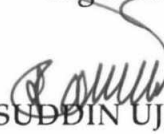
  
**SHAMSUDDIN UJJAN**  
 DIVISIONAL ACCOUNTS OFFICER  
 HIGHWAY DIVISION, SHAHEED BENAZIR ABAD  
 MEMBER OF PROCUREMENT COMMITTEE

  
**ILMUDDIN DAHRI**  
 ASSISTANT ENGINEER,  
 BUILDINGS DIVISION, SHAHEED BENAZIR ABAD  
 MEMBER OF PROCUREMENT COMMITTEE

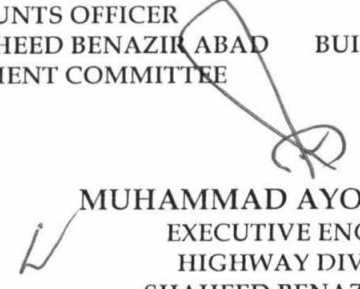
  
**MUHAMMAD AYOUB SHAIKH**  
 EXECUTIVE ENGINEER  
 HIGHWAY DIVISION  
 SHAHEED BENAZIR ABAD  
 CHAIRMAN OF PROCUREMENT COMMITTEE

# COMPERATIVE STATEMENT OF QUOTED RATES

(District Coordination Officer Shaheed Benazir Abad Notification No:PS/DCO/SBA/89, dated.01.07.2010)

Name of Work:- Constt: of road from Nawabshah Sarhari road (Bakhsho Jamali) to village Afzal / Mehar Ali Bhangwar UC Gupchani Taluka Daur mile 0/0-1/7.

Tender Reference No. NIT No. 346 Dated: 07-03-2016.

Method of Procurement: Single Stage One Envelope Procedure.

Tender Published: Published in Dawn English, Jang Urdu, Sobh Sindhi, Ibrat Sindhi. SPPRA Website SNo. 26875.

Sr. No	Name of Contractor.	Rate Quoted.			Part-IV ( 5"Span . Culvert
		Part-I, (Road component).	Part-II, (RCC Pipe Component).	Part-III,(Masonary Structure component).	
01	M/S Khalil Engg: Works	2.24% Below	14.65% Above	21.30% Above	16.60% Above
02	M/S Muhammad Ramzan Brohi & Co.	2.21% Below	14.72% Above	21.80% Above	16.90% Above
03	M/S Atta Muhammad Bughio	2.19% Below	14.75% Above	21.90% Above	16.96% Above
04	M/S Crescent Engg: Works	2.18% Below	14.80% Above	21.99% Above	17% Above
05	M/S Abdul Ghaffar Memon.	2.16% Below	14.86% Above	22% Above	17.10% Above
06	Mr, Muhammad Najib Arin	2.15% Below	14.89% Above	21.90% Above	17.20% Above
07	M/S Muhammad Shahid & Co.	2.13% Below	14.90% Above	22% Above	17.39% Above
08					

Certified that the Tender have been opened before us by Executive Engineer Highway Division Shaheed Benazir Abad.

  
**SHAMSUDDIN UJAN**  
DIVISIONAL ACCOUNTS OFFICER  
HIGHWAY DIVISION, SHAHEED BENAZIR ABAD  
MEMBER OF PROCUREMENT COMMITTEE

  
**ILLAMUDDIN DAHRI**  
ASSISTANT ENGINEER,  
BUILDINGS DIVISION, SHAHEED BENAZIR ABAD  
MEMBER OF PROCUREMENT COMMITTEE

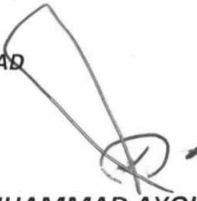
  
**MUHAMMAD AYOUB SHAIKH**  
EXECUTIVE ENGINEER  
HIGHWAY DIVISION  
SHAHEED BENAZIR ABAD  
CHAIRMAN OF PROCUREMENT COMMITTEE



OFFICE OF THE  
**EXECUTIVE ENGINEER**  
**HIGHWAY DIVISION, SHAHEED BENAZIR ABAD.**

*Address: Situated at near Kazi Ahmed road Nawabshah.*

This Office NIT No, TC/G-55/346

Dated: 07-03-2016.

**SUBJECT:** PROCUREMENT COMMITTEE MEETING HELD ON 29-03-2016.

A meeting of the Procurement Committee was held in the office of Executive Engineer, Highway Division, Shaheed Benazir Abad, under the Chairmanship of Executive Engineer.

2. The below mentioned member of Committee attended the meeting to discuss the Bids invited for the Procurement of Works vide Executive Engineer, Highway Division, Shaheed Benazir Abad, letter No. TC/G-55/346, Dated: 07-03-2016 and subsequently hoisted on the website of Sindh Public Procurement Regulatory Authority Sr. No. 26875 and Information Technology Department Government of Sindh.

Following attend the meeting.

1. MR. SHAMSUDDIN UJJAN,  
DIVISIONAL ACCOUNTS OFFICER,  
HIGHWAY DIVISION,  
SHAHEED BENAZIR ABAD. MEMBER

2. MR. ILMUDDIN DAHRI,  
ASSISTANT ENGINEER,  
BUILDINGS DIVISION,  
SHAHEED BENAZIR ABAD. MEMBER

3. During the course of meeting following discussion were made by the Committee.

- i. The Tender received back on dated 29-03-2016, at 1.00 pm & was Opened before the Procurement Committee in presence of representatives of participants,
- ii. The methods of Bidding Documents observed as single envelope.
- iii. The Tender was opened on 29-03-2016 before the Tender Opening Committee.

**SR. NO. 01. CONSTT: OF ROAD FROM NAWABSHAH SARHARI ROAD (BAKHSHO JAMALI) TO VILLAGE AFZAL / MEHAR ALI BHANGWAR UC GUPCHANI TALUKA DAUR MILE 0/0-1/7. A.D.P NO. 1170.**

4. The Committee was informed that 07 Nos Bidders have purchased the Bidding Documents upto Dated: 28-03-2016 and 07 Nos have responded the Bids on Date: 29-03-2016 upto 1:00 pm in the office of Executive Engineer, Highway Division, Shaheed Benazir Abad.

5. During the opening of Tender received, following status was found.

S #	Name of Firms	Raking in Term of Cost	Remarks
01	M/S Khalil Engineering Works	1 <sup>st</sup> Lowest	Lowest
02	M/S Muhammad Ramzan Brohi & Co:	2 <sup>nd</sup> Lowest	Highest
03	M/S Atta Muhammad Bughio	3 <sup>rd</sup> Lowest	Highest
04	M/S Crescent Engineering Works	4 <sup>th</sup> lowest	Highest
05	M/S Abdul Ghaffar Memon	5 <sup>th</sup> lowest	Highest
06	Mr. Muhammad Yaqoob Arain	6 <sup>th</sup> lowest	Highest
07	M/S Muhammad Shahid & Co:	7 <sup>th</sup> lowest	Highest



**SR. NO. 02. CONSTT: OF ROAD FROM NAWABSHAH SARHARI ROAD TO CONNECT NAWABSHAH VARR ROAD VIA HAJI MUHAMMAD BUX BROHI, ALLAH DITTO MAGSI, HAJI JAN MUHAMMAD BROHI & GHULAM HYDER ZARDARI UC KHADHAR & GUPCHANI TALUKA SAKRAND & DAUR MILE 0/0-3/2 A.D.P NO.1171.**

4. The Committee was informed that 06 Nos Bidders have purchased the Bidding Documents upto Dated: 28-03-2016 and 06 Nos have responded the Bids on Date: 29-03-2016 upto 1:00 pm in the office of Executive Engineer, Highway Division, Shaheed Benazir Abad.
5. During the opening of Tender received, following status was found.

S #	Name of Firms	Raking in Term of Cost	Remarks
01	Mr. Muhammad Akram Shaikh	1 <sup>st</sup> Lowest	Lowest
02	M/S Muhammad Ramzan Brohi & Co:	2 <sup>nd</sup> Lowest	Highest
03	M/S Khalil Engineering Works	3 <sup>rd</sup> Lowest	Highest
04	M/S Abdul Ghaffar Memon	4 <sup>th</sup> lowest	Highest
05	M/S Crescent Engineering Works	5 <sup>th</sup> lowest	Highest
06	M/S Atta Muhammad Bughio	6 <sup>th</sup> lowest	Highest

**SR. NO. 03. CONSTT: OF ROAD FROM @ VILLAGE MUHAMMAD KHAN SETHAR TO OLD VILLAGE LAL BUX SHAHANI NEW VILLAGE MUHAMMAD ALAM SHAHANI TALUKA DAUR DISTRICT SHAHEED BENAZIR ABAD MILE 0/0-2/4 A.D.P NO. 1185.**

4. The Committee was informed that 06 Nos Bidders have purchased the Bidding Documents upto Dated: 28-03-2016 and 06 Nos have responded the Bids on Date: 29-03-2016 upto 1:00 pm in the office of Executive Engineer, Highway Division, Shaheed Benazir Abad.
5. During the opening of Tender received, following status was found.

S #	Name of Firms	Raking in Term of Cost	Remarks
01	M/S Atta Muhammad Bughio	1 <sup>st</sup> Lowest	Lowest
02	M/S Crescent Engineering Works	2 <sup>nd</sup> Lowest	Highest
03	M/S Abdul Ghaffar Memon	3 <sup>rd</sup> Lowest	Highest
04	M/S Muhammad Ramzan Brohi & Co:	4 <sup>th</sup> lowest	Highest
05	M/S Muhammad Shahid & Co:	5 <sup>th</sup> lowest	Highest
06	Mr. Muhammad Yaqoob Arain	6 <sup>th</sup> lowest	Highest

6. The Committee thoroughly scrutinized each case / Tender Document, by comparing earth matically and financially with sanctioned estimates / Bill of quantities and criteria for eligibility and minimum qualification as per Bidding Documents.
7. **Recommendation**  
After due deliberation / scrutiny of each Tender Document by the Committee, it was recommended that lowest evaluated responsive Bidder may be awarded the respective Tender.
8. **Decision**  
In view of Para No.7 of this report it is decided that Tenders are being awarded to above mentioned lowest responsive Bidders accordingly.

  
**SHAMSUDDIN LITAN**  
DIVISIONAL ACCOUNTS OFFICER  
HIGHWAY DIVISION, SHAHEED BENAZIR ABAD  
MEMBER OF PROCUREMENT COMMITTEE

  
**ILMUDDIN DAHRI**  
ASSISTANT ENGINEER,  
BUILDINGS DIVISION, SHAHEED BENAZIR ABAD  
MEMBER OF PROCUREMENT COMMITTEE

  
**MUHAMMAD AYOUB SHAIKH**  
EXECUTIVE ENGINEER  
HIGHWAY DIVISION  
SHAHEED BENAZIR ABAD  
CHAIRMAN OF PROCUREMENT COMMITTEE



## BIDDERS' ELEGIBILITY/QUALIFICATION REPORT

Eligibility / Qualification Criteria:

Agency:- *M/S Khalil Engineering Works*

S No.	Eligibility/Qualification Criteria	Yes	No
01	Full name permanent address, mobile No. Fax No, E-Mail Address & the organizational; structure.	Yes	
02	Bio Data of Technical Staff Employees & to be made available for working on the project.	Yes	
03	List of scope & approximate cost of works in hand.	Yes	
04	Financial stability certificate issued by Scheduled Bank.	Yes	
05	Affidavit with be undertaking that the information / particulars provided by him is true & correct.	Yes	
06	Registration Income Tax Department along with NTN.	Yes	
07	The intending Agency / Firms should have Register / Approved with Sindh Revenue Board.	Yes	
08	The intending Agency / Firms have to submit the Affidavit to the effect that his Firm / Agency is not involved in any litigation & left abandoned the work in any Government Department & not black listed.	Yes	
09	List of Machinery & equipments available with documentary evidence of its ownership.	Yes	
10	Documentary evidence of works executed, works in progress & certificate of satisfactory completions of work by the Employers.	Yes	
11	Registration with Pakistan Engineering Council in the relevant field of specialization of work (CE 01) & to the Extent of the Tender amount of each work for the year 2016.	Yes	
12	The earnest money specified would be pledged in the name of Executive Engineer, Highway Division, Shaheed Benazir Abad in the shape of Call Deposit from any Scheduled Bank & must be attached with Bid Documents; otherwise it will not be entertained.	Yes	
13	If Firm / Partner involved in partnership deed, such details & power of attorney will be submitted on affidavit by the proprietor.	Yes	

  
**SHAMSUDDIN UJIAN**  
DIVISIONAL ACCOUNTS OFFICER  
HIGHWAY DIVISION, SHAHEED BENAZIR ABAD  
MEMBER OF PROCUREMENT COMMITTEE

  
**ILMUDDIN DAHRI**  
ASSISTANT ENGINEER,  
BUILDINGS DIVISION, SHAHEED BENAZIR ABAD  
MEMBER OF PROCUREMENT COMMITTEE

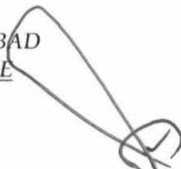
  
**MUHAMMAD AYOUB SHAIKH**  
EXECUTIVE ENGINEER  
HIGHWAY DIVISION  
SHAHEED BENAZIR ABAD  
CHAIRMAN OF PROCUREMENT COMMITTEE

## BIDDERS' ELEGIBILITY / QUALIFICATION REPORT

Eligibility / Qualification Criteria:

Agency:- **Engr. Muhammad Akram Shaikh**

S No.	Eligibility / Qualification Criteria	Yes	No
01	Full name permanent address, mobile No. Fax No, E-Mail Address & the organizational; structure.	Yes	
02	Bio Data of Technical Staff Employees & to be made available for working on the project.	Yes	
03	List of scope & approximate cost of works in hand.	Yes	
04	Financial stability certificate issued by Scheduled Bank.	Yes	
05	Affidavit with be undertaking that the information / particulars provided by him is true & correct.	Yes	
06	Registration Income Tax Department along with NTN.	Yes	
07	The intending Agency / Firms should have Register / Approved with Sindh Revenue Board.	Yes	
08	The intending Agency / Firms have to submit the Affidavit to the effect that his Firm / Agency is not involved in any litigation & left abandoned the work in any Government Department & not black listed.	Yes	
09	List of Machinery & equipments available with documentary evidence of its ownership.	Yes	
10	Documentary evidence of works executed, works in progress & certificate of satisfactory completions of work by the Employers.	Yes	
11	Registration with Pakistan Engineering Council in the relevant field of specialization of work (CE 01) & to the Extent of the Tender amount of each work for the year 2016.	Yes	
12	The earnest money specified would be pledged in the name of Executive Engineer, Highway Division, Shaheed Benazir Abad in the shape of Call Deposit from any Scheduled Bank & must be attached with Bid Documents; otherwise it will not be entertained.	Yes	
13	If Firm / Partner involved in partnership deed, such details & power of attorney will be submitted on affidavit by the proprietor.	Yes	

  
**SHAMSUDDIN UJJAN**  
DIVISIONAL ACCOUNTS OFFICER  
HIGHWAY DIVISION, SHAHEED BENAZIR ABAD  
MEMBER OF PROCUREMENT COMMITTEE

  
**ILMUDDIN DAHRI**  
ASSISTANT ENGINEER,  
BUILDINGS DIVISION, SHAHEED BENAZIR ABAD  
MEMBER OF PROCUREMENT COMMITTEE

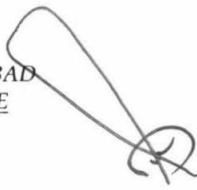
  
**MUHAMMAD AYOUB SHAIKH**  
EXECUTIVE ENGINEER  
HIGHWAY DIVISION  
SHAHEED BENAZIR ABAD  
CHAIRMAN OF PROCUREMENT COMMITTEE

## BIDDERS' ELEGIBILITY/QUALIFICATION REPORT

Eligibility / Qualification Criteria:

Agency:- *M/S Atta Muhammad Bughio*

S No.	Eligibility/Qualification Criteria	Yes	No
01	Full name permanent address, mobile No. Fax No, E-Mail Address & the organizational; structure.	Yes	
02	Bio Data of Technical Staff Employees & to be made available for working on the project.	Yes	
03	List of scope & approximate cost of works in hand.	Yes	
04	Financial stability certificate issued by Scheduled Bank.	Yes	
05	Affidavit with be undertaking that the information / particulars provided by him is true & correct.	Yes	
06	Registration Income Tax Department along with NTN.	Yes	
07	The intending Agency / Firms should have Register / Approved with Sindh Revenue Board.	Yes	
08	The intending Agency / Firms have to submit the Affidavit to the effect that his Firm / Agency is not involved in any litigation & left abandoned the work in any Government Department & not black listed.	Yes	
09	List of Machinery & equipments available with documentary evidence of its ownership.	Yes	
10	Documentary evidence of works executed, works in progress & certificate of satisfactory completions of work by the Employers.	Yes	
11	Registration with Pakistan Engineering Council in the relevant field of specialization of work (CE 01) & to the Extent of the Tender amount of each work for the year 2016.	Yes	
12	The earnest money specified would be pledged in the name of Executive Engineer, Highway Division, Shaheed Benazir Abad in the shape of Call Deposit from any Scheduled Bank & must be attached with Bid Documents; otherwise it will not be entertained.	Yes	
13	If Firm / Partner involved in partnership deed, such details & power of attorney will be submitted on affidavit by the proprietor.	Yes	

  
SHAMSUDDIN UJJAN  
DIVISIONAL ACCOUNTS OFFICER  
HIGHWAY DIVISION, SHAHEED BENAZIR ABAD  
MEMBER OF PROCUREMENT COMMITTEE

  
ILMUDDIN DAHRI  
ASSISTANT ENGINEER,  
BUILDINGS DIVISION, SHAHEED BENAZIR ABAD  
MEMBER OF PROCUREMENT COMMITTEE

  
MUHAMMAD AYOUB SHAIKH  
EXECUTIVE ENGINEER  
HIGHWAY DIVISION  
SHAHEED BENAZIR ABAD  
CHAIRMAN OF PROCUREMENT COMMITTEE

## BIDDERS' ELEGIBILITY / QUALIFICATION REPORT

Eligibility / Qualification Criteria:

Agency:- *M/S Muhammad Ramzan Brohi & Co:*

S No.	Eligibility / Qualification Criteria	Yes	No
01	Full name permanent address, mobile No. Fax No, E-Mail Address & the organizational; structure.	Yes	
02	Bio Data of Technical Staff Employees & to be made available for working on the project.	Yes	
03	List of scope & approximate cost of works in hand.	Yes	
04	Financial stability certificate issued by Scheduled Bank.		No
05	Affidavit with be undertaking that the information / particulars provided by him is true & correct.		No
06	Registration Income Tax Department along with NTN.	Yes	
07	The intending Agency / Firms should have Register / Approved with Sindh Revenue Board.	Yes	
08	The intending Agency / Firms have to submit the Affidavit to the effect that his Firm / Agency is not involved in any litigation & left abandoned the work in any Government Department & not black listed.		No
09	List of Machinery & equipments available with documentary evidence of its ownership.	Yes	
10	Documentary evidence of works executed, works in progress & certificate of satisfactory completions of work by the Employers.	Yes	
11	Registration with Pakistan Engineering Council in the relevant field of specialization of work (CE 01) & to the Extent of the Tender amount of each work for the year 2016.	Yes	
12	The earnest money specified would be pledged in the name of Executive Engineer, Highway Division, Shaheed Benazir Abad in the shape of Call Deposit from any Scheduled Bank & must be attached with Bid Documents; otherwise it will not be entertained.	Yes	
13	If Firm / Partner involved in partnership deed, such details & power of attorney will be submitted on affidavit by the proprietor.		No

  
SHAMSUDDIN UJJAN  
DIVISIONAL ACCOUNTS OFFICER  
HIGHWAY DIVISION, SHAHEED BENAZIR ABAD  
MEMBER OF PROCUREMENT COMMITTEE

  
ILMUDDIN DAHRI  
ASSISTANT ENGINEER,  
BUILDINGS DIVISION, SHAHEED BENAZIR ABAD  
MEMBER OF PROCUREMENT COMMITTEE

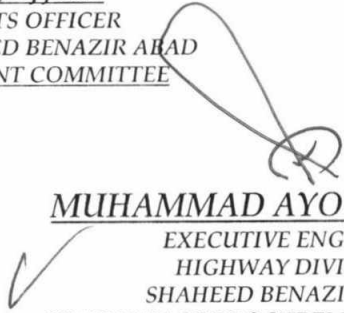
  
MUHAMMAD AYOUB SHAIKH  
EXECUTIVE ENGINEER  
HIGHWAY DIVISION  
SHAHEED BENAZIR ABAD  
CHAIRMAN OF PROCUREMENT COMMITTEE





## BIDDERS' ELEGIBILITY / QUALIFICATION REPORT

Eligibility / Qualification Criteria:

Agency:- *M/S Crescent Engg: Works*

S No.	Eligibility / Qualification Criteria	Yes	No
01	Full name permanent address, mobile No. Fax No, E-Mail Address & the organizational; structure.	Yes	
02	Bio Data of Technical Staff Employees & to be made available for working on the project.		No
03	List of scope & approximate cost of works in hand.	Yes	
04	Financial stability certificate issued by Scheduled Bank.		No
05	Affidavit with be undertaking that the information / particulars provided by him is true & correct.	Yes	
06	Registration Income Tax Department along with NTN.		No
07	The intending Agency / Firms should have Register / Approved with Sindh Revenue Board.	Yes	
08	The intending Agency / Firms have to submit the Affidavit to the effect that his Firm / Agency is not involved in any litigation & left abandoned the work in any Government Department & not black listed.	Yes	
09	List of Machinery & equipments available with documentary evidence of its ownership.		No
10	Documentary evidence of works executed, works in progress & certificate of satisfactory completions of work by the Employers.	Yes	
11	Registration with Pakistan Engineering Council in the relevant field of specialization of work (CE 01) & to the Extent of the Tender amount of each work for the year 2016.	Yes	
12	The earnest money specified would be pledged in the name of Executive Engineer, Highway Division, Shaheed Benazir Abad in the shape of Call Deposit from any Scheduled Bank & must be attached with Bid Documents; otherwise it will not be entertained.	Yes	
13	If Firm / Partner involved in partnership deed, such details & power of attorney will be submitted on affidavit by the proprietor.		No

  
SHAMSUDDIN UJAN  
DIVISIONAL ACCOUNTS OFFICER  
HIGHWAY DIVISION, SHAHEED BENAZIR ABAD  
MEMBER OF PROCUREMENT COMMITTEE

  
ILMUDDIN DAHRI  
ASSISTANT ENGINEER,  
BUILDINGS DIVISION, SHAHEED BENAZIR ABAD  
MEMBER OF PROCUREMENT COMMITTEE

  
MUHAMMAD AYOUB SHAIKH  
EXECUTIVE ENGINEER  
HIGHWAY DIVISION  
SHAHEED BENAZIR ABAD  
CHAIRMAN OF PROCUREMENT COMMITTEE

## BIDDERS' ELEGIBILITY / QUALIFICATION REPORT

*Eligibility / Qualification Criteria:*

**Agency:- M/S Abdul Ghaffar Memon**

S No.	Eligibility/Qualification Criteria	Yes	No
01	Full name permanent address, mobile No. Fax No, E-Mail Address & the organizational; structure.	Yes	
02	Bio Data of Technical Staff Employees & to be made available for working on the project.	Yes	
03	List of scope & approximate cost of works in hand.	Yes	
04	Financial stability certificate issued by Scheduled Bank.	Yes	
05	Affidavit with be undertaking that the information / particulars provided by him is true & correct.	Yes	
06	Registration Income Tax Department along with NTN.	Yes	
07	The intending Agency / Firms should have Register / Approved with Sindh Revenue Board.	Yes	
08	The intending Agency / Firms have to submit the Affidavit to the effect that his Firm / Agency is not involved in any litigation & left abandoned the work in any Government Department & not black listed.	Yes	
09	List of Machinery & equipments available with documentary evidence of its ownership.		No
10	Documentary evidence of works executed, works in progress & certificate of satisfactory completions of work by the Employers.	Yes	
11	Registration with Pakistan Engineering Council in the relevant field of specialization of work (CE 01) & to the extent of the Tender amount of each work for the year 2016.		No
12	The earnest money specified would be pledged in the name of Executive Engineer, Highway Division, Shaheed Benazir Abad in the shape of Call Deposit from any Scheduled Bank & must be attached with Bid Documents; otherwise it will not be entertained.	Yes	
13	If Firm / Partner involved in partnership deed, such details & power of attorney will be submitted on affidavit by the proprietor.	Yes	

  
**SHAMSUDDIN UJJAN**  
DIVISIONAL ACCOUNTS OFFICER  
HIGHWAY DIVISION, SHAHEED BENAZIR ABAD  
MEMBER OF PROCUREMENT COMMITTEE

  
**ILMUDDIN DAHRI**  
ASSISTANT ENGINEER,  
BUILDINGS DIVISION, SHAHEED BENAZIR ABAD  
MEMBER OF PROCUREMENT COMMITTEE

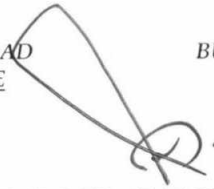
  
**MUHAMMAD AYOUB SHAIKH**  
EXECUTIVE ENGINEER  
HIGHWAY DIVISION  
SHAHEED BENAZIR ABAD  
CHAIRMAN OF PROCUREMENT COMMITTEE

## BIDDERS' ELEGIBILITY / QUALIFICATION REPORT

*Eligibility / Qualification Criteria:*

**Agency:- Mr. Muhammad Yaqoob Arain**

S No.	Eligibility / Qualification Criteria	Yes	No
01	Full name permanent address, mobile No. Fax No, E-Mail Address & the organizational; structure.	Yes	
02	Bio Data of Technical Staff Employees & to be made available for working on the project.		No
03	List of scope & approximate cost of works in hand.		No
04	Financial stability certificate issued by Scheduled Bank.		No
05	Affidavit with be undertaking that the information / particulars provided by him is true & correct.	Yes	
06	Registration Income Tax Department along with NTN.	Yes	
07	The intending Agency / Firms should have Register / Approved with Sindh Revenue Board.	Yes	
08	The intending Agency / Firms have to submit the Affidavit to the effect that his Firm / Agency is not involved in any litigation & left abandoned the work in any Government Department & not black listed.	Yes	
09	List of Machinery & equipments available with documentary evidence of its ownership.		No
10	Documentary evidence of works executed, works in progress & certificate of satisfactory completions of work by the Employers.		No
11	Registration with Pakistan Engineering Council in the relevant field of specialization of work (CE 01) & to the Extent of the Tender amount of each work for the year 2016.		No
12	The earnest money specified would be pledged in the name of Executive Engineer, Highway Division, Shaheed Benazir Abad in the shape of Call Deposit from any Scheduled Bank & must be attached with Bid Documents; otherwise it will not be entertained.	Yes	
13	If Firm / Partner involved in partnership deed, such details & power of attorney will be submitted on affidavit by the proprietor.		No

  
**SHAMSUDDIN UJJAN**  
DIVISIONAL ACCOUNTS OFFICER  
HIGHWAY DIVISION, SHAHEED BENAZIR ABAD  
MEMBER OF PROCUREMENT COMMITTEE

  
**ILMUDDIN DAHRI**  
ASSISTANT ENGINEER,  
BUILDINGS DIVISION, SHAHEED BENAZIR ABAD  
MEMBER OF PROCUREMENT COMMITTEE

  
**MUHAMMAD AYOUB SHAIKH**  
EXECUTIVE ENGINEER  
HIGHWAY DIVISION  
SHAHEED BENAZIR ABAD  
CHAIRMAN OF PROCUREMENT COMMITTEE

## BIDDERS' ELEGIBILITY / QUALIFICATION REPORT

*Eligibility / Qualification Criteria:*

**Agency:- M/S Muhammad Shahid & Co:**

S No.	Eligibility / Qualification Criteria	Yes	No
01	Full name permanent address, mobile No. Fax No, E-Mail Address & the organizational; structure.	Yes	
02	Bio Data of Technical Staff Employees & to be made available for working on the project.		No
03	List of scope & approximate cost of works in hand.		No
04	Financial stability certificate issued by Scheduled Bank.		No
05	Affidavit with be undertaking that the information / particulars provided by him is true & correct.	Yes	
06	Registration Income Tax Department along with NTN.	Yes	
07	The intending Agency / Firms should have Register / Approved with Sindh Revenue Board.	Yes	
08	The intending Agency / Firms have to submit the Affidavit to the effect that his Firm / Agency is not involved in any litigation & left abandoned the work in any Government Department & not black listed.	Yes	
09	List of Machinery & equipments available with documentary evidence of its ownership.		No
10	Documentary evidence of works executed, works in progress & certificate of satisfactory completions of work by the Employers.		No
11	Registration with Pakistan Engineering Council in the relevant field of specialization of work (CE 01) & to the Extent of the Tender amount of each work for the year 2016.		No
12	The earnest money specified would be pledged in the name of Executive Engineer, Highway Division, Shaheed Benazir Abad in the shape of Call Deposit from any Scheduled Bank & must be attached with Bid Documents; otherwise it will not be entertained.	Yes	
13	If Firm / Partner involved in partnership deed, such details & power of attorney will be submitted on affidavit by the proprietor.		No

  
**SHAMSUDDIN UJAN**  
DIVISIONAL ACCOUNTS OFFICER  
HIGHWAY DIVISION, SHAHEED BENAZIR ABAD  
MEMBER OF PROCUREMENT COMMITTEE

  
**ILMUDDIN DAHRI**  
ASSISTANT ENGINEER,  
BUILDINGS DIVISION, SHAHEED BENAZIR ABAD  
MEMBER OF PROCUREMENT COMMITTEE

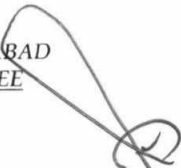
  
**MUHAMMAD AYOUB SHAIKH**  
EXECUTIVE ENGINEER  
HIGHWAY DIVISION  
SHAHEED BENAZIR ABAD  
CHAIRMAN OF PROCUREMENT COMMITTEE

# NOTICE INVITING TENDERS

The Tenders on B-I form for the works mentioned below are invited from all the interested parties meeting the eligibility criteria to participate as per SPPRA Rules.

Sr. No.	Name of Scheme	Estimated Cost	Completion Period	Cost of Tender	Earnest Money
1.	Construction of Tough Tile / Paver Road in Village Haji Lashkar Khan Bijarani UC Gulwali Taluka Tangwani.	2.000	09 Months	3000/-	05%
2.	Construction of Tough Tile / Paver Road in Village Mir Guil Mohammad Khan Bijarani UC Gulwali Taluka Tangwani.	4.900	09 Months	3000/-	05%
3.	Construction of Tough Tile / Paver Road in Village Mohammad Umar via Ali Akbar Shar UC-02 Kandhkot.	5.000	09 Months	3000/-	05%
4.	Const. of Tough Tile / Paver Road in Village Yaar Mohammad Nindwani UC Saifal Taluka Tangwani "Remaining Work"	5.000	09 Months	3000/-	05%

### TERMS & CONDITIONS:-

- The application for purchase of Tender documents should accompany 5% earnest money of the estimated cost in shape of call deposit from any of scheduled Bank pledged in the name of Executive Engineer Buildings Division Kashmir @ Kandhkot from the date of publication of NIT in newspapers upto 28.03.2016 during office hours and will be opened on the same day at 4.00 PM.
- The earnest money of the amount shown against each work be deposited in Govt: Treasury or any Schedule Bank. The Call Deposit receipt as earnest money be produced at the time of applying for the Tender, without which Tender will not be considered.
- No Conditional Tender will be entertained / accepted.
- The Procuring Agency may reject all or any bid, subject to the relevant provision of SPPRA Rules.
- The works costing 2.500(M) and above those contractors who are registered with Pakistan Engineering Council (P.E.C) Islamabad be eligible to participate in the Tenders.
- The Estimate, Drawing, Design and Specifications can be seen on any working day during office hours in the office of the undersigned.

- Blank Tender Forms can be obtained from the office of the undersigned on payment of cost of Tender (non-refundable) as per programme given below.
- The successful Contractors whose Tender are accepted will have to obtained adhesive stamp on payment according to schedule prescribed in the Sixth Financial Act 1991.
- Professional Tax, Sales Tax, Income Tax will be deducted from the bills of suppliers / contractors as per rules.

The terms and conditions of the contract / agreement will become operative upon the contractors as soon as the tender is accepted and work order issued.

**NOTE:** In case any of the Tenders went un-responded the tenders will be issued and received back and opened on **12.04.2016**.

Say No to Corruption

**EXECUTIVE ENGINEER  
BUILDINGS DIVISION  
KASHMIRE @ KANDHKOT**

INF-KRY No. 797/16



## OFFICE OF THE EXECUTIVE ENGINEER, HIGHWAYS DIVISION, SHAHEED BENAZIRABAD

Address: Situated at Near Kazi Ahmed Road, Phone No. 0244-9370133, Fax No. 0244-366648

NO. TC/G-55/346 Dated: 07/03/2016

**“TO ACTIVATE ROADS AS ‘SERVICE’ TO PEOPLE  
AND TO OPEN UP THE PROVINCE BY MAXIMUM ACCESS”**

**NOTICE INVITING TENDERS**

Sealed Standard Bidding Documents are invite from the interested Bidders / Firms as per SPPRA Rules 2010 of Procurement Advertisement for the following Works:

Sr. #	Name of Work	Estimated Cost In Million	Earnest Money 3%	Tender Fee	Time Allowed
01	Constt: of road from Nawabshah Sarhari Road (Bakhsho Jamali) to Village Afzal / Mehar Ali Bhangwar UC Gupchani Taluka Daur Mile 0/0-1/7, A.D.P No. 1170	25.60	768,000	3000	15 Months
02	Constt: of road from Nawabshah Sarhari Road to connect Nawabshah Varr Road via Haji Muhammad Bux Brohi, Allah Ditto Magsi, Haji Jan Muhammad Brohi & Ghulam Hyder Zardari UC Khachar & Gupchani Taluka Sakrand & Daur Mile 0/0-3/2, A.D.P No. 1171.	48.00	1,440,000	3000	15 Months
03	Constt: of road from @ Village Muhammad Khan Sethar to Old Village Lal Bux Shahani New Village Muhammad Alam Shahani Taluka Daur District Shaheed Benazirabad Mile 0/0-2/4, A.D.P No. 1185.	37.50	1,125,000	3000	15 Months

### CONDITIONS

- The blank Bid forms will be available at the office of the undersigned situated at near Kazi Ahmed Road Nawabshah during office hours on payment of the tender fee, in cash (non-refundable) specified against each work on any working day from the date of publication upto 28-03-2016 @ 1.00 p.m.
- The Tenders will be received back on 29-03-2016 upto 1.00 p.m. & opened on same date @ 1.45 p.m. In the presence of Interesting Bidders or their authorized representatives on same date.

- Tender documents will be opened in the presence of Procurement Committee approved by the Secretary, Works & Service Karachi Sindh.
- a) In case the undersigned is out of Headquarters the same will be received and opened on next working day on same timing, b) In case the tenders are un-responded, the next dates for issue & opening of tenders will be as under:-  
i) The tenders will be issued upto 14-04-2016 upto 1.00 p.m. and tenders will be received back on 15.04.2016 upto 1.00 p.m. and opened on the same date at 1.45 p.m. In the presence of Interesting Bidders or their authorized representatives on same date.
- To participate in tendering details for eligibility are as under:-  
a) Full Name, Permanent Address, Mobile No., Fax No., E-Mail Address & Organizational structure;  
b) Bio-data of technical staff employed & to be made available for working on the project.  
c) List of scope & approximate cost of works in hand.  
d) Financial stability certificate issued by Scheduled Bank.  
e) Affidavit with be undertaking that the information / particulars provided by him is true & correct.  
f) Registration with Income Tax Department along with NTN.  
g) The intending agency/firm should have registration/approved with Sindh Revenue Board.  
h) The intending agency/firms have to submit the Affidavit to the effect that his firm / agency is not involved in any litigation and has not abandoned any work in any Government Department & not blacklisted.  
i) List of machinery & equipments available with documentary evidence of its ownership.  
j) Documentary evidence of works executed, works in progress & certificate of satisfactory completion of work by the Employers.  
k) Registration with Pakistan Engineering Council in the relevant field of specialization of work (CE 01) & to the extent of the Tender amount of each work for the year 2016.
- The earnest money specified would be pledged in the name of Executive Engineer, Highway Division, Shaheed Benazirabad in shape of Call Deposit from any scheduled Bank and must be attached with Bid Documents, otherwise it will not be entertained.
- If Firm / Partner involved in partnership deed, such details & power of attorney will be submitted on affidavit by the proprietor.
- Conditional & telegraphic Tender will not be entertained.
- The Procuring Agency may reject all or any Bid or proposal at any time prior to the acceptance of a Bid or proposal, subject to the relevant provision of SPPRA Rules.
- The Tender can be seen on SPPRA Website: [www.pprasinhd.gov.pk](http://www.pprasinhd.gov.pk)

INF-KRY No. 794/16

Say No to Corruption

**EXECUTIVE ENGINEER  
HIGHWAYS DIVISION  
SHAHEED BENAZIRABAD**

**GINEER  
IN BADIN**



## ڪاميابين جا درڪلي سگهن ايس ايگزيڪيوٽو انجنيئر هائي وي ڊويزن شهيد بينظير آباد

### ٽينڊر گهرائڻ لاءِ نوٽيس

معياري ٽينڊر سٽڊ بيلڪ پروڪيورمينٽ ريڪويليٽري اٿارٽي 2010 جي اهليت جي معيار تي پروو هينڊڊ دلچسپي رکندڙ بندو/ فرمز کان هيٺ ڄاڻايل ڪمن لاءِ بي-1 فارمن مهربندي ٽينڊر گهريل آهن.

11.3.2016

نمبر	ڪم جو نالو	ڪيٿل لاکڙ (ملين)	سوٽي رقم	ٽينڊر في	مدو
1.	نوابشاهه سرهاڙي روڊ (بخشو جمالي کان وٺي ڳوٺ افضل/ مهر علي پنڳوار يو سي گيجائي تعلقو ڊوڙ ميل 0/0-1/7 اي ڊي پي نمبر 1170 تائين روڊ جي تعمير)	25.60	768000	3%	3000
2.	نوابشاهه سرهاڙي روڊ کان وٺي ڪنيڪٽ نوابشاهه وار روڊ ذريعي حاجي محمد بخش بروهي، الله ڌنو مگسي، حاجي جان محمد بروهي ۽ غلام حيدر زرداري يو سي ڪنڌار ۽ گيجائي تعلقو سڪرنڊ ۽ ڊوڙ ميل 0/0-3/2 اي ڊي پي نمبر 1171 تائين روڊ جي تعمير)	48.00	1440000		3000
3.	ڳوٺ محمد خان سيار کان برٽي ڳوٺ لعل بخش شاهي وٺي ڳوٺ محمد عالم شاهي تعلقو ڊوڙ ضلعو شهيد بينظير آباد ميل 0/0-2/4 اي ڊي پي نمبر 1185 تائين روڊ جي تعمير	37.50	1125000		3000

1. ڪورا واڪ فارمز هيٺ صحيح ڪندڙ جي آفيس واقع قاضي احمد روڊ نوابشاهه مان هر هڪ ڪم جي سامهون ڄاڻايل ٽينڊر في (ناقابل واپسي) جي اداڪي ڪرڻ تي تاريخ 28-03-2016 تي منجهند 1:00 وڳي تائين آفيس وقت دوران حاصل ڪري سگهجن ٿا.

2. ٽينڊر 29-03-2016 تي منجهند 1:00 وڳي تائين واپس وصول ڪيا و سگهڻي ڏينهن منجهند 1:45 وڳي دلچسپي رکندڙ ليڪيڊرن يا سندن مجاز نمائندن جي موجودگي وٽ ٽينڊرنگ ڪميٽي پاران ڪوٺيا ويندا.

3. ٽينڊر دستاويزات سيڪريٽري ورڪس اينڊ سروسز ڪراچي سٽڊ پاران منظور ڪيل پروڪيورمينٽ ڪميٽي جي موجودگيءَ وٽ ڪوٺيا ويندا.

4. اي) هيٺ صحيح ڪندڙ جي هيڊڪوارٽر کان ٻاهر هجڻ جي صورت ۾ ٽينڊر بي ڪم واري ڏينهن تي ساڳئي وقت تي وصول ڪوٺيا ويندا.

ب) ٽينڊرنگ ڪميٽي جي موٽ نه ملڻ جي صورت ۾ ٽينڊرن جي اجراءَ ۽ ڪولڻ جي تاريخ هيٺين ريت آهي

i) ٽينڊر 14-04-2016 تي منجهند 1:00 وڳي جاري ڪيا ويندا ۽ 15-04-2016 تي منجهند 1:00 وڳي وصول ڪيا ويندا ۽ ساڳئي ڏينهن تي 1:45 وڳي دلچسپي رکندڙ واڪ ڏيندڙن يا سندن مجاز نمائندن جي موجودگيءَ وٽ ساڳئي تاريخ تي ڪوٺيا ويندا.

5. ٽينڊرنگ وٽ شرڪت لاءِ اهليت هيٺين ريت آهي:

a. ڇهه ماڻهن تي مشتمل پتو، موٽيل نمبر، فيڪس نمبر، اي ميل ايڊريس ۽ آرگنائيزيشن اسٽرڪچر

b. پراجيڪٽ جي ڪم لاءِ ٽيڪنيڪل اسٽاف جي بايوڊيٽا مهيا ڪئي وڃي.

c. هٿ هيٺ ڪمن جي فهرست ۽ ڪيٿل لاکڙ.

d. شيڊيول بينڪ مان جاري ٿيل فنانشل اسٽيٽيبلٽي سرٽيفڪيٽ.

e. اهو حلف نامو جيڪو به معلومات ڏيڻ واريون آهن سي سڃيون ۽ صحيح آهن.

f. انڪر ٽيڪس ڊيپارٽمينٽ سان رجسٽريشن (اين تي اين) سرٽيفڪيٽ سان گڏ.

g. دلچسپي رندڙ ايجنسي/ فرمز لاءِ ضروري ته سنڌ روٽيٽو بورڊ سان رجسٽرڊ/ اڀرود هجن.

h. دلچسپي رکندڙ ايجنسي/ فرمز لاءِ ضروري آهي ته حلف نامو جمع ڪرائين جنهن ۾ ڄاڻايل هجي ته فرم/ ايجنسي ڪنهن به مقدمي پاڙي و ملوث نه ۽ ڪنهن به گورنمينٽ ڊپارٽمينٽ جو ڪوبه اڏورو ڇڏيل نه آهي ۽ نه ئي فرم بيلڪ لسٽ ٿيل آهي.

i. موجود ڪيل سامان ۽ مشينري جي لسٽ دستاويزي ثبوت سان گڏ جنهن ۾ ان جي مالڪي ڄاڻايل هجي.

j. ابحار ڏنل/ هٿ ۾ موجود ڪمن جو دستاويزي ثبوت ۽ آجرن پاران ڪمن جي اطمينان بخش تڪميل جو سرٽيفڪيٽ.

k. پاڪستان انجنيئرنگ ڪائونسل کان لاڳاپيل فيلڊ ۾ مهارت (CE-01) تحت ۽ رجسٽريشن سال 2016 جي هر هڪ ڪم لاءِ وڌيل رقم جو ٽينڊر مقرر سوٽي رقم ڪنهن به شيڊيول بينڪ کان ڪال ڊپازٽ جي صورت ۾ ايگزيڪيوٽو انجنيئر هاءِ ويز ڊويزن شهيد بينظير آباد جي نالي تي شامل ڪرڻ گهرجي ۽ واڪ دستاويزات سان لازمي ريت لڳل هئڻ گهرجي بي صورت ۾ ان تي غور نه ڪيو ويندو. اگر فرم، پارٽنر شپ جي صورت ۾ تفصيلات ۽ پاور آف اٿارٽي تحت معلومات پروويڊن پاران ايڊيٽوريٽي تي جمع ڪرائيندا.

8. شرط ۽ ٽيڊرلارڪ ٽينڊر قبول نه هوندا.

9. پروڪيورنگ ايجنسي ڪنهن به يا سمورن ٽينڊرن/ واڪ پروپوزلز کي ايس بي بي آر اي رولز موجب رد ڪرڻ جو حق محفوظ رکي ٿي جيڪي واڪ ڏيندڙن جي درخواست تي ڪين ٻڌائي سگهجن ٿا.

10. ايس بي بي آر اي جي ويب سائيٽ: www.pprasindh.gov.pk تي به ڏسي سگهجن ٿا.

## ايگزيڪيوٽو انجنيئر هاءِ وي ڊويزن شهيد بينظير آباد

INF/KRY.No.794/2016

SAY NO TO CORRUPTION

ڪريشن جو خاتمو آڻيو

سٽڊ ۽ تعليم جي بهتري لاءِ، علمي ۽ پنهنجو بيلڪ لڪي 8 3 9 8 تي ايس ايس ڪرين

محمد صدر خود محفوظ ناهي ته عوار ڪي ڪهڙو تحفظ فراهم ڪندي پوليس هونديون ايس ايس بي مٽياري احمد شيخ پوليس پوسٽ کي ڪاٽ هڻڻ جو نوٽيس وٺندي ڏي ايس بي نيو سميڊ آڊاڊ کان رپورٽ طلب ڪري ورتي آهي.

بڻيها 18 انصاف جي گهر

بظاهري ۾ ڳالهائيندي سمات رڪنيت، عذرا، اله، رڪي، خان بهادر ۽ ٻين چيو ته حاڪم زادي ڪجهه ڏينهن اڳ و صبح جو پنهنجي پاڻ کي ٻانهي تي باهه ڏئي جڏهن ته ان جو ازار هن سندس مڙس گلزار ڏاڻيڻو تي هنيو جنهن کان پوءِ پوليس گلزار کي گرفتار به ڪري وئي جڏهن ته هاڻ پوليس اسان کي بي گناهه تنگ ڪري رهي آهي هن اعليٰ اختيارين کان گهر ڪيون ٿا ته اسان جو ڀڄو بي گناهه آهي هن کي آزاد ڪري اسان سان انصاف ڪيو وڃي ۽ هن مامري و جيڪي بااثر ماڻهن جا لڪيل هٿ آهن انهن کي بي نقاب ڪيو وڃي

بڻيها 19 لاڙڪاڻو/ڳوٺاڻا

ڊانهندي چيو ته عبدالرحمان، ممتاز، غفار منهنجي 20 جريب زرعي زمين تي بلاچوار قبضو ڪيو آهي ۽ جنهن مان 15 جريب منهنجي نالي تي ۽ 5 جريب منهنجي گهر واري جي نالي تي آهي، جڏهن ته ڳوٺ ۾ مون مسجد پڻ ٺهرائي آهي، جنهن ڏانهن ايندڙ رستي تي پڻ ڄاڻايل جوابدار قبضو ڪرڻ چاهين ٿا، هن وڌيڪ چيو ته ڄاڻايل جوابدارن مون کي زمين تان هٿ ڪڍڻ لاءِ ڌمڪائي رهيا آهن، جيڪا مون سان وڏي زيادتي آهي، جڏهن ته منهنجي پٽن ۽ منهنجي ٽي بي بي گناهه ڪوڙا ڪيس داخل ڪرائي حراسان ڪري رهيا آهن ۽ پوليس به انهن سان پٽ بڻيل آهي، جنهن ڪري اسان جو جيڪڏهن نجات ٿي ويو آهي، هن چيو ته مون مٿان پڻ ڪوڙو ڪيس داخل ڪرائي لاکڙ ڪرايو ويو پر آءٌ عدالت جي حڪم تي ضمانت تي آهيان ۽ هاڻي مٿي ڄاڻايل جوابدار مورتاڻ ڌمڪيون ڏئي رهيا آهن، جڏهن ته منهنجي ٻين پٽ احمد علي، محمد علي ۽ عمران کي بي گناهه گرفتار ڪرايو آهي، هن مطالبو ڪيو ته ڄاڻايل جوابدارن خلاف ڪارروائي ڪري سندس زمين تان قبضو هٽايو وڃي بي صورت ۾ احتجاج جاري رکندس.

بڻيها 20 جروار/پاڻي

اهي انهي اهلي سان فنڪشنل ليگ طرفان جروار ۾ پوري صدر خالد احمد گبول اياز گبول، نظير احمد، عبدالطيف گبول غلام روزدار واحد بخش عالماني، رمضان ڪجهڙي رڪارڊ روزدار جي اڳواڻي ۾ مائيلو چوڪ کان پريس ڪلب تائين ريلي ڪئي وئي. اڳواڻن خطاب ڪندي چيو ته جروار سميت ٻن پوسين دلراءُ ۽ صاحب لنڊ پوسين ۾ جر جو پاڻي زهريلو ٿي وڃڻ سبب هزارين غريب ماڻهون هن موذي مرض و رکروڙي ويا آهن، جنهن جو ڪارڻ ڪارخانن ۽ پيپل فيڪٽرين جو زهريلو پاڻي واهڻ ۽ پڇڻ آهي ۽ اڪثر ڪارخانا زهريلو پاڻي زمينن تائين زرعي ضايع ڪن ٿا جنهن سبب جر جو پاڻي ڪارڻ ٿي ويو آهي. اڳواڻن چيو ته اسان صرف هڪ ڊيپ شيرعلي و سروي ڪئي آهي ته ٻن سالن ۾ 86 ماڻهون انهي هيٺائينس وٽ فوت ٿي چڪا آهن ۽ هزارين تعداد ۾ ماڻهن کي هيٺائينس بي ۽ سي آهي پر غريب ماڻهو تيستن جون گريون فيون نه هئڻ سبب پنهنجو علاج نه ڪرائي سگهن ٿا ۽ ٻيو آرڱرڪر انهن جي زندگي جو ڏيڻو رسامي وڃي ٿو هئڻ وڌيڪ چيو ته جن ماڻهن جو علاج هلي ٿو ته انهن ماڻهن کي به تائينر تي علاج نه ڏنو وڃي ٿو. انهن مطالبو ڪيو ته ڪارخانن جو زهريلو پاڻي واهڻ ۾ پڇڻ بند ڪيو وڃي ۽ جروار ۾ ٽي روڊا فرني ميڊيڪل ڪمپل لڳائي علائقي واسين جي تيستون ڪيون وڃن

بڻيها 21 پنکڙي ۾ مظاهرو

اڳيان ڌڙو هنيو، انهي موقعي تي اڳواڻن چيو ته ٿرڊي پورٽ ڪيٽلازي جو انچارج خوشحال باڪستان پرويڪٽرن ۽ پنهنجا نوازي ڪري رهيو آهي ۽ پئسن عيوض يامن پسنڌ ماڻهن جا حصي پٽي تي فارو پري ٿو، هنن چيو ته يونٽ انچارج وڏي پئماني تي ڪريشن ڪري رهيو آهي، هنن چيو ته اسان ڪافي پيرا شڪايتون ڪيون آهن پر اسان کي به ٻڌڻ لاءِ تيار ناهي ۽ اسان کي وٽس خاموش رهندڙن لاءِ ڌمڪايو وڃي ٿو، هنن ان موقعي تي چيائڻ ڏنو ته جيڪڏهن قدر نه ڪيو ويو ته احتجاجي تحريڪ هلائينداسين

بڻيها 22 کيرڊ/ٻاراڻا گهٽ نه ڪيا

ٻين ڏانهندي چيو ته حڪومت جيڪڏهن هڪ روييا ڊيزل ۽ پيٽرول جو ڊوٽي ٿي ته ٽرانسپورٽ پڪڙم 120 کان 20 روييا وڌايو ڇڏين، جڏهن ته پيٽرول جو اڳهه 120 مان 60 روييا ٿيو آهي پر ڪرايا اهي ساڳيا آهن، روي ٽئين روش ڪندي ٽرانسپورٽن جو ٽا ته اسان جي گاڏيون سي اين جي تي هلن ٿيون، اسين چو ڪرايا گهٽايون، هنن حڪومت کان پريزور ايجل ڪئي آهي ته ڪيرڊ ۽ گاڏين جا ڪرايا گهٽايا وڃن، بي صورت ۾ اسين احتجاج ڪنداسين

بڻيها 23 خيرپور/هوٽال

ڊسٽرڪٽ سيشن ڪورٽ خيرپور سامهون ادر ڪيڊر اسٽانڊن طرفان 125 هين ڏينهن به پڪ هوٽال جاري رکي وئي، ڪمپن جي موجود اسٽانڊ مٿس ڪلهوڙو، طارون سومري، گدا حسين ملاح، بربڪ گهٽاهي، تعبير الله آزاد ۽ ٻين ڪمپن تان ريلي ڪندي ڪجهه روي ڏي، مارچ ڪندي چونڊيل نمائندن ۽ تعليم کاتي جي ڪامورن خلاف نعرا هڻيا، ان موقعي تي اسٽانڊ خطاب ڪندي چيو ته گڏريل ڪيترائي غرضي

جي مين پرامري بوائز اسڪول ۾ نياڻين جي داخلا ڪرائي وڃي ۽ نئين سال 2016 جو نشون نصاب ڏيئي نياڻين جي تعليم کي فروغ ڏياريو وڃي

بڻيها 27 بيماري

اڳيان احتجاجي مظاهرو، اعليٰ اختيارين کان نوٽيس وٺڻ جو مطالبو، ان سلسلي ۾ مختلف ڳوٺن جي ڳوٺاڻن علي حسن مينڀلو، قمر الدين نازجو حيات اڀرو، نياز عباسي، محمد عباس مينڀلو، ۽ ٻين صحافين سان ڳالهائيندي ٻڌايو ته مڇر مار ٺهڻ جو ٿيڻ ڪري علائقي ۾ مڇرن جا ڪٽڪ ڪاهي پيا آهن، جنهن سبب معصور پار ۽ عمر زيده ماڻهون راتيون جاڳڻ تي مجبور ٿي ويا آهن، مڇرن جو آزار وڌي وڃڻ سبب مليريا سميت ڪيترن ئي خطرناڪ بيمارين سبب سوين ماڻهون بيماري ۾ حڪوڙي چڪا آهن، جڏهن ته سرڪاري اسپتال مان مليريا ۽ بجاه واريون ڊوائون اٽل ۽ عطائي ڊاڪٽر غريب ۽ بي بهج اهوچه ماڻهن کي پنهنجن هٿن سان ڦرن لڳي

بڻيها 28 هالاڻي/ملاڙو

ٿي پيا آهن بوسيز جي اهڙن ملازمن دي سي ۽ اسسٽنٽ ڊائريڪٽر لوڪل گورنمينٽ نوشهروفيروز کي ايجل ڪئي آهي ته خدا واسطي اسان ملازمن تي رحر جي نظر فرمائي اسان جو ٻن مهينن کان رڪيل ڪهڙيون جاري ڪري اسان جي پریشاني دور ڪئي وڃي هنن چيو ته پگهارون نه ملڻ ڪري اسان سخت پریشان آهيون بچوڻو آهيون گهر جو خرچ ڀارڻ تعليم سميت سمورين ضرورتن پگهار مان پوريون ڪندا آهيون پر پگهار نه ملڻ ڪري پریشاني گهٽ ٿيڻ بدران وڌندي رهي ٿي اهو اسان سان ظلم ناحق آهي اسان ڪاڏي وڃون ڪئين ڪيون ڪنهن کي ڏانهن ڏيون ڪا ڳالهه سمجهه ورتي اچي جڏهن اسان کي پگهار نه ملندي ته اسان جو حال ڪهڙو هوندو اهو سڀ اعليٰ عملدار سمجهي سگهن ٿا قرضن جي اڳيان شرمندا ٿي رهيا آهيون مالي ۽ معاشي حالت سڦير ۽ خراب آهي خدا اسان تي رحر ڪاڏو وڃي

بڻيها 29 لاڙڪاڻو/ڳوٺاڻا

ڪيو آهي ۽ جنهن مان 15 جريب منهنجي نالي تي ۽ 5 جريب منهنجي گهر واري جي نالي تي آهي، جڏهن ته ڳوٺ ۾ مون مسجد پڻ ٺهرائي آهي، جنهن ڏانهن ايندڙ رستي تي پڻ ڄاڻايل جوابدار قبضو ڪرڻ چاهين ٿا، هن وڌيڪ چيو ته ڄاڻايل جوابدارن مون کي زمين تان هٿ ڪڍڻ لاءِ ڌمڪائي رهيا آهن، جيڪا مون سان وڏي زيادتي آهي، جڏهن ته منهنجي پٽن ۽ منهنجي ٽي بي بي گناهه ڪوڙا ڪيس داخل ڪرائي حراسان ڪري رهيا آهن ۽ پوليس به انهن سان پٽ بڻيل آهي، جنهن ڪري اسان جو جيڪڏهن نجات ٿي ويو آهي، هن چيو ته مون مٿان پڻ ڪوڙو ڪيس داخل ڪرائي لاکڙ ڪرايو ويو پر آءٌ عدالت جي حڪم تي ضمانت تي آهيان ۽ هاڻي مٿي ڄاڻايل جوابدار مورتاڻ ڌمڪيون ڏئي رهيا آهن، جڏهن ته منهنجي ٻين پٽ احمد علي، محمد علي ۽ عمران کي بي گناهه گرفتار ڪرايو آهي، هن مطالبو ڪيو ته ڄاڻايل جوابدارن خلاف ڪارروائي ڪري سندس زمين تان قبضو هٽايو وڃي بي صورت ۾ احتجاج جاري رکندس

بڻيها 30 رهواسين وٽ تاء

شڪايتون پڻ ڪيون ويون آهن پر هن وقت تائين بجلي بحال نه ٿي سگهي آهي، جنهن ڪري شهرين ۾ تاء پکڙي ويو آهي، شهرين صحافين کي ٻڌايو ته اسان بجلي جا بل باقاعدي سان جمع ڪرائيندا آهيون، ان جي باوجود اسان جي بجلي بند ڪئي وئي آهي، هنن چيو ته بجلي جي بقاهاجات جن ڏي رهيا آهن، انهن جي بجلي کائي وڃي، ان جي سزا سمورين شهرين کي نه ڏني وڃي، هنن چيائڻ ڏنيون ڪي جيڪڏهن بجلي بحال نه ڪئي وڃي ته جيڪو انتظاميا خلاف احتجاجي تحريڪ شروع ڪئي ويندي

بڻيها 31 گدهو/ويڪسين

سخت زخمي ڪري، وڏو جنهن کي مائٽ تعلقه اسپتال کڻائي آيا، جتي ويڪسين نه ملڻ ڪري مرض جي حالت سخت خراب ٿي وئي، مرض جي مائٽ ڏانهندي چيو ته اسين غريب آهيون، اسان وٽ خانگي ويڪسين لاءِ پئسا نه آهن، اسين علاج ڪهان ڪرائينداسين

بڻيها 32 حيات بڻيها/اسڪول

اسڪول جي بلڊنگ کي ٺهڻي ڪيترائي سال گذري ويا آهن پر بلڊنگ جي هڪ دفعو مٿس نه ڪئي وئي آهي شهرين شاهنواز شهيد ۽ راهب کوزر بن احتجاج ڪندي چيو ته بلڊنگن زيون هئڻ سبب نياڻيون خوف و هروڙ ورتل هونديون هر روز هن بلڊنگ جا ڇاڙو ڪرڻ ٿا هئن چيو ته اڳ ۾ ڇاڙو ڪرڻ سبب شاگردن ٻيڙيون زخمي ٿيون هيون، هن چيو ته اسڪول جي چوڌواري به مڪمل طور ڊهي پئي آهي چوڌواري نه هجڻ سبب هڪ وڏو مسئلو آهي، هنن تعليم کاتي جي صورتي وزير نثار

بڻيها 23 ڪهڙو ۽ سيڪريٽري تعليم ڊپٽي ڪمشنر

گهڙوڪي وهان جي وس وارن کان گهر ڪئي ته نياڻين جي حال تي رحر کائي شالائي مڀل اسڪول کي بلڊنگ ۽ چوڌواري ڏني وڃي ته جيئن حيات بڻيها اس پاس جي علائقن جون نياڻيون تعليم جهڙي زهرور کان مهروڙ نه ٿي سگهن وهان جي سوين نياڻين جي ڊاٽو تي لڳل تعليم بچائي وڃي ۽ اسان جي اسڪول کي

بڻيها 24

بڻيها 25



