

BIDDING DATA

(This section should be filled in by the Engineer/Procuring Agency before issuance of the Bidding Documents).

(a). **Name of Procuring Agency:-** Executive Engineer (Education Works)
Division Shikarpur.

DISTRICT ADP SCHEMES (Electrical Works)

(b). **Brief Description of Works:-** ADP 2328 REHABILITATION OF EXISTING BUILDING
BOYS / GIRLS PRIMARY ELEMENTARY SCHOOL OF
DISTRICT SHIKARPUR TALUKA SHIKARPUR 2013-14
PROGRAMME.

GGPS HATHI DAR KASSAI MUHALLA

(c). **Procuring Agency's address:-** Executive Engineer (Education Works) Division Shikarpur
Near GBHS No.II Shikarpur.

(d). **Estimated Cost:-** 0.200 (Millions).

(e). **Amount of Bid Security:-** 2% (Fill in lump sum amount or in % age of bid amount /estimated cost, but not exceeding 5%)

(f). **Period of Bid Validity (days):-** 60 Days (Not more than sixty days).

(g). **Security Deposit:-(including bid security):-** 10%
(in % age of bid amount /estimated cost equal to 10%)

(h). **Percentage, if any, to be deducted from bills:-** 7.50% Income tax

(i). **Deadline for Submission of Bids along with time :-** As Per NIT

(j). **Venue, Time, and Date of Bid Opening:-** Near GBHS II (Shikarpur As Per NIT).

(k). **Time for Completion from written order of commence: -** 06 Months

(L). **Liquidity damages:-** -NIL- (0.05 of Estimated Cost or Bid cost per day of delay, but total not exceeding 10%).

(m). **Deposit Receipt No:** _____ **Date:** _____ **Amount:Rs:** _____

Bank _____
(n) **D.R.NO:** _____ **DATED:-** _____ . **Amount 500/-**(Rupees: Five Hundred only).

(o). **Tender issued to Mr. / M/s** _____ **Govt Contractor.**

EXECUTIVE ENGINEER
EDUCATION WORKS DIVISION
SHIKARPUR



(SCHEDULE (B))

**NAME OF WORK:- REHABILITATION OF EXISTING BUILDING FOR BOYS / GIRLS
PRIMARY / ELEMENTARY SCHOOLS OF DISTRICT DISTRICT & TALUKA
SHIKARPUR (2013-14 PROG:) AT GGPS HATHI DAR KASAI MOHALLA
SHIKARPUR. ADP # 2328 (ELECTRIFICATION)**

S.NO:	Description	Qty	Rate	Unit	Amount
Part "A" Schedule Items					
1	Wiring for light or fan point with 3/029 PVCinsulated wire in 20mm (3/4") channel patti on surface as required (S.No. 129 P-15).	50	910	per point	45500
2	Wiring for plug point with 3/029 PVC insulated wire in 20mm (3/4") channel patti on surface as required (S.I.No:130 P- No:15)	10	742	per point	7420
3	Providing & laying (MAIN or SUB MAIN) PVC insulated with size 2-7/029 copper conductor in 3/4" dia PVC conduit on surface (S.I.No:3 P- No:1)	150	171	P.Mtr	25650
4	Providing & laying (MAIN or SUB MAIN) PVC insulated with size 2-7/026 (4mm ²) copper conductor in 3/4" dia PVC conduit on surface (S.I. No:4 P- No:1).	75	200	P.Mtr	15000
5	Providing & fixing one way SP 5amp switch flush type(S.I.No:219 P- No:3)	50	54	P.No	2700
6	Providing & fixing two pin 5amp plug & socket (S.I.No:225 P- No:33)	10	83	P.No	830
7	Providing & fixing 3pin 10/15amp plug & socket flush type (S.I. No:222 P- No:33)	1	151	P.No	151
9	Providing & fixing circuit breaker 6,10,15,20, 30,40,50 & 63amp SP (TB-5S) on prepared board as required (S.I.No:202 P- No:30)	7	916	P.No	6412
10	Providing & fixing circuit breaker 6,10,15,20, 30,40,50 & 63amp DP (TB-5S) on prepared board as required. (S.I.No:202 P- No:30)	2	2456	P.No	4912
11	Providing & fixing Bakelite ceiling rose with two terminals (S.I. No:228 P- No:33)	12	72	P.No	864
12	Providing & fixing Brass Battern holder c(S.I.No:232 P- No:33)	24	70	P.No	1680
13	Providing & fixing Brass Ceiling fan 56" (good quality) (S.I.No:235 P- No:34)	13	3185	P.No	41405
14	Providing & laying (MAIN or SUB MAIN) PVC insulated with size 2-7/032 (10 mm ²) copper conductor in 1" dia PVC conduit on surface (S.I.No:6 P- No:1).	50	428	per Meter	21400

Total:- 173924

S.NO:	Description	Qty	Rate	Unit	Amount
Part "B" Old Schedule Items 2004					
1	P/F distribution metal board double shutter to accommodate circuit breakers including painting with enamel paint and for other simmlar job on su face (S.I.No:5 P- No:13)	1.5	907.96	Each	1362
2	P/F mild steel bar fan clamp 15.8 mm (5/8")dia suitable for RCC roof (S.I.No:1 (c) P- No:14)	12	141.01	Each	1692
3	P/F 1-40 walts tube light complete with 40 wats4.0" long rod chok , starter an l putty with Phillips components including necessary electric connection and fixing on wall or ceilling etc complete. (S.I.No:1 P- No:33)	3	396.00	Each	1188
4	P/F wall bracket light fancy type superior quality I/n necessary electric connection and fixing on wall or ceilling etc complete (S.I.No:5 P- No:33)	6	497.00	Each	2982
5	P/F Energy sever superior quality I/c fixing on existing holder etc complete S.I.No:6 P- No:33)	19	497.00	Each	9443
6	P/F bulbs 100 walts (S.I.No:7 P- No:33)	3	25.00	Each	75
7	P/F A.C ceiling fan regulator on metal board recessed in the walls column and covered with plastic sheet (S.I.No:2b P- No:14)	12	124.30	Each	1491.6
8	P/F earthing set with 2x2x1/4" cooper plate burried in groud at a depth of 12" or less if water comes out from the ground level with salt and chorcoal , etc,in/c.making the pit 12"deep by excavation of all type of soil. Earth plat to be connected with No:8	1	3610.04	Each	3610



EXECUTIVE ENGINEER
EDUCATION WORKS DIVISION
SHIKARPUR.

Total:- 21844

DRAUGHTSMAN
EDUCATION WORKS DIVISION
SH KARPUR.

TOTAL (CSR:)

Part "A" %Above / Below _____ Total Amount _____

Part "E" %Above / Below _____ Total Amount _____

Part "C" %Above / Below _____ Total Amount _____

Total "A+B+C" _____

CONTRACTOR

EXECUTIVE ENGINEER
EDUCATION WORK DIVISION,
SHIKARPUR

BIDDING DATA

(This section should be filled in by the Engineer/Procuring Agency before issuance of the Bidding Documents).

(a). Name of Procuring Agency:- Executive Engineer (Education Works)
Division Shikarpur.

DISTRICT ADP SCHEMES (Electrical Works)

(b). Brief Description of Works:- ADP 2329 REHABILITATION OF EXISTING BUILDING
BOYS / GIRLS PRIMARY ELEMENTARY SCHOOL OF
DISTRICT SHIKARPUR TALUKA SHIKARPUR 2013-14
PROGRAMME.

GBPS KATH MADI

(c). Procuring Agency's address:- Executive Engineer (Education Works) Division Shikarpur
Near GBHS No.II Shikarpur.

(d). Estimated Cost:- 0.200 (Millions).

(e). Amount of Bid Security:- 2% (Fill in lump sum amount or in % age of bid amount /estimated cost, but not exceeding 5%)

(f). Period of Bid Validity (days):- 60 Days (Not more than sixty days).

(g). Security Deposit:- (including bid security):- 10%
(in % age of bid amount /estimated cost equal to 10%)

(h). Percentage, if any, to be deducted from bills:- 7.50% Income tax

(i). Deadline for Submission of Bids along with time :- As Per NIT

(j). Venue, Time, and Date of Bid Opening:- Near GBHS II (Shikarpur As Per NIT).

(k). Time for Completion from written order of commence: - 06 Months

(L). Liquidity damages:- -NIL- (0.05 of Estimated Cost or Bid cost per day of delay, but total not exceeding 10%).

(m). Deposit Receipt No: _____ Date: _____ Amount: Rs: _____

Bank _____

(n) D.R.NO: _____ DATED: _____ Amount 500/- (Rupees: Five Hundred only).

(o). Tender issued to Mr. / M/s _____ Govt. Contractor.

EXECUTIVE ENGINEER
EDUCATION WORKS DIVISION
SHIKARPUR

(SCHEDULE (B)).

**NAME OF WORK:- REHABILITATION OF EXISTING BUILDING FOR BOYS / GIRLS
PRIMARY / ELEMENTARY SCHOOLS OF DISTRICT DISTRICT & TALUKA
SHIKARPUR (2013-14 PROG:) AT GBPS KATH MADI SHIKARPUR. ADP # 2329
(ELECTRIFICATION)**

S.NO:	Description	Qty	Rate	Unit	Amount
Part"A" Schedule Items					
1	Wiring for light or fan point with 3/.029 PVCinsulated wire in 20mm (3/4") channel patti on surface as required (S.No. 129 P-15).	50	910	per point	45500
2	Wiring for plug point with 3/.029 PVC insulated wire in 20mm (3/4") channel patti on surface as required (S.I.No:130 P- No:15)	10	742	per point	7420
3	Providing & laying (MAIN or SUB MAIN) PVC insulated with size 2-7/.029 copper conductor in 3/4" dia PVC conduit on surface (S.I.No:3 P- No:1)	150	171	P.Mtr	25650
4	Providing & laying (MAIN or SUB MAIN) PVC insulated with size 2-7/.036 (4mm ²) copper conductor in 3/4" dia PVC conduit on surface (S.I.No:4 P- No:1).	60	200	P.Mtr	12000
5	Providing & fixing one way SP 5amp switch flush type(S.I.No:219 P- No:33)	50	54	P.No	2700
6	Providing & fixing two pin 5amp plug & socket (S.I.No:225 P- No:33)	10	83	P.No	830
7	Providing & fixing 3pin 10/15amp plug & socket flush type (S.I.No 222 P- No:33)	1	151	P.No	151
9	Providing & fixing circuit breaker 6,10,15,20, 30,40,50 & 63amp SP (TB-5S) on prepared board as required (S.I.No:202 P- No:30)	7	916	P.No	6412
10	Providing & fixing circuit breaker 6,10,15,20, 30,40,50 & 63amp DP (TB-5S) on prepared board as required. (S.I.No:202 P- No:30)	2	2456	P.No	4912
11	Providing & fixing Bakelite ceiling rose with two terminals (S.I.No:228 P- No:33)	12	72	P.No	864
12	Providing & fixing Brass Battern holder c(S.I.No:232 P- No:33)	19	70	P.No	1330
13	Providing & fixing Brass Ceiling fan 56" (good quality) (S.I.No:235 P- No:34)	15	3185	P.No	47775
14	Providing & laying (MAIN or SUB MAIN) PVC insulated with size 2-7/.052 (10 mm ²) copper conductor in 1" dia PVC conduit on surface (S.I.No:6 P- No:1).	40	428	per Meter	17120

Total:- 172664

S.NO:	Description	Qty	Rate	Unit	Amount
Part "B" Old Schedule Items 2004					
1	P/F distribution metal board double shutter to accommodate circuit breaker: including painting with enamel paint and for other similar job on surface (S.I.No:5 P- No:13)	1.5	907.96	Each	1362
2	P/F mild steel bar fan clamp 15.8 mm (5/8") dia suitable for RCC roof (S.I.No:1 (c) P- No:14)	15	141.01	Each	2115
3	P/F 1-40 watts tube light complete with 40 watts 4.0" long rod chok , starter and putty with Phillips components including necessary electric connection and fixing on wall or ceiling etc complete. (S.I.No:1 P- No:33)	5	396.00	Each	1980
4	P/F wall bracket light fancy type superior quality 1/n necessary electric connection and fixing on wall or ceiling etc complete (S.I.No:5 P- No:33)	9	497.00	Each	4473
5	P/F Energy sever superior quality I/c fixing on existing holder etc complete (S.I.No:6 P- No:33)	15	497.00	Each	7455
6	P/F bulbs 100 watts (S.I.No:7 P- No:33)	4	25.00	Each	100
7	P/F A.C ceiling fan regulator on metal board recessed in the walls column and covered with plastic sheet (S.I.No:2b P- No:14)	15	124.30	Each	1865
8	P/F earthing set with 2x2x1/4" cooper plate buried in ground at a depth of 12" or less if water comes out from the ground level with salt and charcoal ,etc,in/c.making the pit 12" deep by excavation of all type of soil. Ear h plat to be connected with No:8	1	3610.04	Each	3610

[Signature]
DR. UGHTSMAN
 EDUCATION WORKS DIVISION
 SHIKARPUR.

TOTAL (CSR:)

Part "A" %Above / Below _____ Total Amount _____

Part "B" %Above / Below _____ Total Amount _____

Part "C" %Above / Below _____ Total Amount _____

Total "A+B+C" _____

[Signature]
 Total:- 22960

[Signature]
EXECUTIVE ENGINEER
 EDUCATION WORKS DIVISION
 SHIKARPUR.

CONTRACTOR

EXECUTIVE ENGINEER
 EDUCATION WORK DIVISION,
 SHIKARPUR

BIDDING DATA

(This section should be filled in by the Engineer/Procuring Agency before issuance of the Bidding Documents).

(a). Name of Procuring Agency:- Executive Engineer (Education Works)
Division Shikarpur.

DISTRICT ADP SCHEMES (Electrical Works)

(b). Brief Description of Works:- ADP 2335 REHABILITATION OF EXISTING BUILDING
BOYS / GIRLS PRIMARY ELEMENTARY SCHOOL OF
DISTRICT SHIKARPUR TALUKA G.YASIN (2013-14)
PROGRAMME.

GBPS AGHA SADDARUDDIN DURRANI

(c). Procuring Agency's address:- Executive Engineer (Education Works) Division Shikarpur
Near GBHS No.II Shikarpur.

(d). Estimated Cost:- 0.200 (Millions).

(e). Amount of Bid Security:- 2% (Fill in lump sum amount or in % age of bid amount /estimated cost, but not exceeding 5%)

(f). Period of Bid Validity (days):- 60 Days (Not more than sixty days).

(g). Security Deposit:-(including bid security):- 10%
(in % age of bid amount /estimated cost equal to 10%)

(h). Percentage, if any, to be deducted from bills:- 7.50% Income tax

(i). Deadline for Submission of Bids along with time :- As Per NIT

(j). Venue, Time, and Date of Bid Opening:- Near GBHS II (Shikarpur As Per NIT).

(k). Time for Completion from written order of commence: - 06 Months

(L). Liquidity damages:- -NIL- (0.05 of Estimated Cost or Bid cost per day of delay, but total not exceeding 10%).

(m). Deposit Receipt No: _____ Date: _____ Amount:Rs: _____
Bank _____

(n) D.R.NO: _____ DATED: _____ Amount 500/- (Rupees: Five Hundred only).

(o). Tender issued to Mr. / M/s _____ Govt: Contractor.

EXECUTIVE ENGINEER
EDUCATION WORKS DIVISION
SHIKARPUR

(SCHEDULE (B))

**NAME OF WORK:- REHABILITATION OF EXISTING BUILDING FOR BOYS / GIRLS
PRIMARY / ELEMENTARY SCHOOLS OF DISTRICT SHIKARPUR (2013-14 PROG:)
AT GBPS AGHA SADARDIN DURANI TALUKA GHARI YASIN. ADP # 2335
(ELECTRIFICATION)**

S.NO:	Description	Qty	Rate	Unit	Amount
Part"A" Schedule Items					
1	Wiring for light or fan point with 3/.029 PVCinsulated wire in 20mm (3/4") channel patti on surface as required (S.No. 129 P-15).	44	910	per point	40040
2	Wiring for plug point with 3/.029 PVC insulated wire in 20mm (3/4") channel patti on surface as required (S.I.No:130 P- No:15)	8	742	per poin	5936
3	Providing & laying (MAIN or SUB MAIN) PVC insulated with size 2-7/.029 copper conductor in 3/4" dia PVC conduit on surface (S.I.No:3 P- No:1)	150	171	P.Mtr	25650
4	Providing & laying (MAIN or SUB MAIN) PVC insulated with size 2-7/.036 (4mm2) copper conductor in 3/4" dia PVC conduit on surface (S.I.No:4 P- No:1).	80	200	P.Mtr	16000
5	Providing & fixing one way SP 5amp switch flush type(S.I.No:219 P- No:33)	44	54	P.No	2376
6	Providing & fixing two pin 5amp plug & socket (S.I.No:225 P- No:33)	8	83	P.No	664
7	Providing & fixing 3pin 10/15amp plug & socket flush type (S.I.No:222 P- No:33)	1	151	P.No	151
9	Providing & fixing circuit breaker 6,10,15,20, 30,40,50 & 63amp SP (TB-5S) on prepared board as required (S.I.No:202 P- No:30)	6	916	P.No	5496
10	Providing & fixing circuit breaker 6,10,15,20, 30,40,50 & 63amp DP (TB-5S) on prepared board as required. (S.I.No:202 P- No:30)	1	2456	P.No	2456
11	Providing & fixing Bakelite ceiling rose with two terminals (S.I.No:228 P- No:33)	20	72	P.No	1440
12	Providing & fixing Brass Battern holder c(S.I.No:232 P- No:33)	22	70	P.No	1540
13	Providing & fixing Brass Ceiling fan 56" (good quality) (S.I.No:235 P- No:34)	16	3185	P.No	50960
14	Providing & laying (MAIN or SUB MAIN) PVC insulated with size 2-7/.052 (10 mm2) copper conductor in 1" dia PVC conduit on surface (S.I.No:6 P- No:1).	50	428	per Meter	21400

Total:- 174109

S.NO:	Description	Qty	Rate	Unit	Amount
Part "B" Old Schedule Items 2004					
1	P/F distribution metal board double shutter to accommodate circuit breakers including painting with enamel paint and for other simmlar job on surface (S.I.No:5 P- No:13)	1.5	907.96	Each	1362
2	P/F mild steel bar fan clamp 15.8 mm (5/8")dia suitable for RCC roof (S.I.No:1 (c) P- No:14)	16	141.01	Each	2256
3	P/F 1-40 walts tube light complete with 40 wats4.0" long rod chok , starter and putty with Phillips components including necessary electric connection and fixingon wall or ceilling etc complete. (S.I.No:1 P- No:33)	4	396.00	Each	1584
4	P/F wall bracket light fancy type superior quality I/n necessary electric connection and fixing on wall or ceilling etc complete (S.I.No:5 P- No:33)	6	497.00	Each	2982
5	P/F Energy sever superior quality I/c fixing on existing holder etc comp etc (S.I.No:6 P- No:33)	15	497.00	Each	7455
6	P/F bulbs 100 walts (S.I.No:7 P- No:33)	3	25.00	Each	75
7	P/F A.C ceiling fan regulator on metal board recessed in the walls column and covered with plastic sheet (S.I.No:2b P- No:14)	16	124.30	Each	1989
8	P/F earthing set with 2x2x1/4" cooper plate burried in groud at a depth of 12" or less if water comes out from the ground level with salt and chorcoal ,etc,in/c.making the pit 12"deep by excavation of all type of soil. Earth plat to be connected with No:8	1	3610.04	Each	3610

Total:- 21313

[Signature]
DRAUGHTSMAN
EDUCATION WORKS DIVISION
SHIKARPUR.

[Signature]
EXECUTIVE ENGINEER
EDUCATION WORKS DIVISION
SHIKARPUR.

TOTAL (CSR:)

Part "A" %Above / Below _____ Total Amount _____

Part "B" %Above / Below _____ Total Amount _____

Part "C" %Above / Below _____ Total Amount _____

Total "A+B+C" _____

CONTRACTOR

EXECUTIVE ENGINEER
EDUCATION WORK DIVISION,
SHIKARPUR

BIDDING DATA

(This section should be filled in by the Engineer/Procuring Agency before issuance of the Bidding Documents).

(a). **Name of Procuring Agency:-** Executive Engineer (Education Works)
Division Shikarpur.

DISTRICT ADP SCHEMES (Electrical Works)

(b). **Brief Description of Works:-** ADP 2336 REHABILITATION OF EXISTING BUILDING
BOYS / GIRLS PRIMARY ELEMENTARY SCHOOL OF
DISTRICT SHIKARPUR TALUKA G.YASIN (2013-14)
PROGRAMME.

GBPS QABALO

(c). **Procuring Agency's address:-** Executive Engineer (Education Works) Division Shikarpur
Near GBHS No.II Shikarpur.

(d). **Estimated Cost:-** 0.050 (Millions).

(e). **Amount of Bid Security:-** 2% (Fill in lump sum amount or in % age of bid amount /estimated cost, but not exceeding 5%)

(f). **Period of Bid Validity (days):-** 60 Days (Not more than sixty days).

(g). **Security Deposit:-(including bid security):-** 10%
(in % age of bid amount /estimated cost equal to 10%)

(h). **Percentage, if any, to be deducted from bills:-** 7.50% Income tax

(i). **Deadline for Submission of Bids along with time :-** As Per NIT

(j). **Venue, Time, and Date of Bid Opening:-** Near GBHS II (Shikarpur As Per NIT).

(k). **Time for Completion from written order of commence: -** 03 Months

(L). **Liquidity damages:-** -NIL- (0.05 of Estimated Cost or Bid cost per day of delay, but total not exceeding 10%).

(m). **Deposit Receipt No:** _____ **Date:** _____ **Amount:Rs:** _____
Bank _____

(n) **D.R.NO:** _____ **DATED:** _____ **Amount 300/-**-(Rupees: Three Hundred only).

(o). **Tender issued to Mr. / M/s** _____ **Govt: Contractor.**

EXECUTIVE ENGINEER
EDUCATION WORKS DIVISION
SHIKARPUR

(SCHEDULE (B)).

**NAME OF WORK:- REHABILITATION OF EXISTING BUILDING FOR BOYS / GIRLS
PRIMARY / ELEMENTARY SCHOOLS OF DISTRICT SHIKARPUR (2013-14 PROG:)
AT GBPS QABALO TALUKA GHARI YASIN. ADP # 2336 (ELECTRIFICATION)**

S.NO:	Description	Qty	Rate	Unit	Amount
Part "A" Schedule Items					
1	Wir ng for light or fan point with 3/.029 PVCinsulated wire in 20mm (3/4 ") channel patti on surface as required (S.No. 129 P-15).	13	910	per point	11830
2	Wiring for plug point with 3/.029 PVC insulated wire in 20mm (3/4") channel patti on surface as required (S.I.No:130 P- No:15)	3	742	per point	2226
3	Providing & laying (MAIN or SUB MAIN) PVC insulated with size 2- 7/.029 copper conductor in 3/4" dia PVC conduit on surface (S.I.No:3 P- No:1)	30	171	P.Mtr	5130
4	Providing & fixing one way SP 5amp switch flush type(S.I.No:219 P- No:3.1)	13	54	P.No	702
5	Providing & fixing two pin 5amp plug & socket (S.I.No:225 P- No:33)	3	83	P.No	249
6	Providing & fixing 3pin 10/15amp plug & socket flush type (S.I.No:222 P- No:33)	1	151	P.No	151
7	Providing & fixing circuit breaker 6,10,15,20, 30,40,50 & 63amp SP (TB-5S) on prepared board as required (S.I.No:202 P- No:30)	3	916	P.No	2748
8	Providing & fixing circuit breaker 6,10,15,20, 30,40,50 & 63amp DP (TB-5S) on prepared board as required. (S.I.No:202 P- No:30)	1	2456	P.No	2456
9	Providing & fixing Bakelite ceiling rose with two terminals (S.I.No:228 P- No:33)	8	72	P.No	576
10	Providing & fixing Brass Battern holder c(S.I.No:232 P- No:33)	5	70	P.No	350
11	Providing & fixing Brass Ceiling fan 56" (good quality) (S.I.No:235 P- No:34)	4	3185	P.No	12740
12	Providing & laying (MAIN or SUB MAIN) PVC insulated with size 2- 7/.052 (10 mm ²) copper conductor in 1" dia PVC conduit on surface (S.I.No:6 P- No:1).	10	428	per Meter	4280

Total:- 43438

S.NO:	Description	Qty	Rate	Unit	Amount
Part "B" Old Schedule Items 2004					
1	P/F distribution metal board double shutter to accommodate circuit breakers including painting with enamel paint and for other simmlar job on surface (S.I.No:5 P- No:13)	1	907.96	Each	908
2	P/F mild steel bar fan clamp 15.8 mm (5/8")dia suitable for RCC roof (S.I.No:1 (c) P- No:14)	4	141.01	Each	564
3	P/F 1-40 walts tube light complete with 40 wats4.0" long rod chok , starter and putty with Phillips components including necessary electric connection and fixingon wall or ceilling etc complete. (S.I.No:1 P- No:33)	2	396.00	Each	792
4	P/F wall bracket light fancy type superior quality I/n necessary electric connection and fixing on wall or ceilling etc complete (S.I.No:5 P- No:33)	2	497.00	Each	994
5	P/F Energy sever superior quality I/c fixing on existing holder etc comp ete (S.I.No:6 P- No:33)	5	497.00	Each	2485
6	P/F bulbs 100 walts (S.I.No:7 P- No:33)	2	25.00	Each	50
7	P/F A.C ceiling fan regulator on metal board recessed in the walls columa and covered with plastic sheet (S.I.No:2b P- No:14)	4	124.30	Each	497
8	P/F ea thing set with 2x2x1/4" cooper plate burried in groud at a depth of 12" or less if water comes out from the ground level with salt and chorcoal ,etc,in/c.making the pit 12"deep by excavation of all type of soil. Earth plat to be connected with No:8	1	3610.04	Each	3610

[Signature]
DRAUGHTSMAN
 EDUCATION WORKS DIVISION
 SHIKARPUR,

[Signature]
 Total:- 9900
EXECUTIVE ENGINEER
 EDUCATION WORKS DIVISION
 SHIKARPUR.

TOTAL (CSR:)

Part "A" %Above / Below _____ Total Amount _____

Par: "B" %Above / Below _____ Total Amount _____

Par: "C" %Above / Below _____ Total Amount _____

Total "A+B+C" _____

CONTRACTOR

EXECUTIVE ENGINEER
 EDUCATION WORK DIVISION,
 SHIKARPUR

BIDDING DATA

(This section should be filled in by the Engineer/Procuring Agency before issuance of the Bidding Documents).

(a). **Name of Procuring Agency:-** Executive Engineer (Education Works)
Division Shikarpur.

DISTRICT ADP SCHEMES (Electrical Works)

(b). **Brief Description of Works:-** ADP 2338 REHABILITATION OF EXISTING BUILDING
BOYS / GIRLS PRIMARY ELEMENTARY SCHOOL OF
DISTRICT SHIKARPUR TALUKA G.YASIN (2013-14)
PROGRAMME.

GBPS MAIN MADEJI

(c). **Procuring Agency's address:-** Executive Engineer (Education Works) Division Shikarpur
Near GBHS No.II Shikarpur.

(d). **Estimated Cost:-** 0.050 (Millions).

(e). **Amount of Bid Security:-** 2% (Fill in lump sum amount or in % age of bid amount /estimated cost, but not exceeding 5%)

(f). **Period of Bid Validity (days):-** 60 Days (Not more than sixty days).

(g). **Security Deposit:-(including bid security):-** 10%
(in % age of bid amount /estimated cost equal to 10%)

(h). **Percentage, if any, to be deducted from bills:-** 7.50% Income tax

(i) **Deadline for Submission of Bids along with time :-** As Per NIT

(j). **Venue, Time, and Date of Bid Opening:-** Near GBHS II (Shikarpur As Per NIT).

(k). **Time for Completion from written order of commence: -** 06 Months

(L). **Liquidity damages:-** -NIL- (0.05 of Estimated Cost or Bid cost per day of delay, but total not exceeding 10%).

(m). **Deposit Receipt No:** _____ **Date:** _____ **Amount:Rs:** _____
Bank _____

(n) **D.R.NO:** _____ **DATED:** _____ **Amount 500/- (Rupees: Five Hundred only).**

(o). **Tender issued to Mr. / M/s** _____ **Govt: Contractor.**

EXECUTIVE ENGINEER
EDUCATION WORKS DIVISION
SHIKARPUR

(SCHEDULE (B))

**NAME OF WORK:- REHABILITATION OF EXISTING BUILDING FOR BOYS / GIRLS
PRIMARY / ELEMENTARY SCHOOLS OF DISTRICT SHIKARPUR (2013-14 PROG:)
AT GBPS MAIN MADEJI TALUKA GHARI YASIN. ADP # 2338 (ELECTRIFICATION)**

S.NO:	Description	Qty	Rate	Unit	Amount
Part "A" Schedule Items					
1	Wiring for light or fan point with 3/029 PVCinsulated wire in 20mm (3/4") channel patti on surface as required (S.No. 129 P-15).	50	910	per point	45500
2	Wiring for plug point with 3/029 PVC insulated wire in 20mm (3/4") channel patti on surface as required (S.I.No:130 P- No:15)	10	742	per point	7420
3	Providing & laying (MAIN or SUB MAIN) PVC insulated with size 27/029 copper conductor in 3/4" dia PVC conduit on surface (S.I.No:3 P- No:1)	150	171	P.Mtr	25650
4	Providing & laying (MAIN or SUB MAIN) PVC insulated with size 27/036 (4mm ²) copper conductor in 3/4" dia PVC conduit on surface (S.I.No:4 P- No:1).	55	200	P.Mtr	11000
5	Providing & fixing one way SP 5amp switch flush type(S.I.No:219 P- No:33)	50	54	P.No	2700
6	Providing & fixing two pin 5amp plug & socket (S.I.No:225 P- No:33)	10	83	P.No	830
7	Providing & fixing 3pin 10/15amp plug & socket flush type (S.I.No:222 P- No:33)	1	151	P.No	151
9	Providing & fixing circuit breaker 6,10,15,20, 30,40,50 & 63amp SP (TB-5S) on prepared board as required (S.I.No:202 P- No:30)	7	916	P.No	6412
10	Providing & fixing circuit breaker 6,10,15,20, 30,40,50 & 63amp DP (TB-5S) on prepared board as required. (S.I.No:202 P- No:30)	2	2456	P.No	4912
11	Providing & fixing Bakelite ceiling rose with two terminals (S.I.No:228 P- No:33)	15	72	P.No	1080
12	Providing & fixing Brass Battern holder c(S.I.No:232 P- No:33)	24	70	P.No	1680
13	Providing & fixing Brass Ceiling fan 56" (good quality) (S.I.No:235 P- No:34)	15	3185	P.No	47775
14	Providing & laying (MAIN or SUB MAIN) PVC insulated with size 27/052 (10 mm ²) copper conductor in 1" dia PVC conduit on surface (S.I.No:6 P- No:1).	40	428	per Meter	17120

Total:- 172230

S.NO:	Description	Qty	Rate	Unit	Amount
Part"13" Old Schedule Items 2004					
1	P/F distribution metal board double shutter to accommodate circuit breakers including painting with enamel paint and for other similar job on surface (S.I.No:5 P- No:13)	1.5	907.96	Each	1362
2	P/F mild steel bar fan clamp 15.8 mm (5/8")dia suitable for RCC roof (S.I.No:1 (c) P- No:14)	15	141.01	Each	2115
3	P/F 1-40 watts tube light complete with 40 watts 4.0" long rod chok , starter and putty with Phillips components including necessary electric connection and fixing on wall or ceiling etc complete. (S.I.No:1 P- No:33)	5	396.00	Each	1980
4	P/F wall bracket light fancy type superior quality I/n necessary electric connection and fixing on wall or ceiling etc complete (S.I.No:5 P- No:33)	6	497.00	Each	2982
5	P/F Energy sever superior quality I/c fixing on existing holder etc complete (S.I.No:6 P- No:33)	19	497.00	Each	9443
6	P/F bulbs 100 watts (S.I.No:7 P- No:33)	3	25.00	Each	75
7	P/F A.C ceiling fan regulator on metal board recessed in the walls column and covered with plastic sheet (S.I.No:2b P- No:14)	15	124.30	Each	1864.5
8	P/F earthing set with 2x2x1/4" cooper plate buried in ground at a depth of 12" or less if water comes out from the ground level with salt and chorcoal etc, in/c. making the pit 12" deep by excavation of all type of soil. Earth plat to be connected with No:8	1	3610.04	Each	3610

[Signature]
DRAUGHTSMAN
 EDUCATION WORKS DIVISION
 SHIKARPUR.

TOTAL (CSR:)

Part "A" %Above / Below _____ Total Amount _____

Part "B" %Above / Below _____ Total Amount _____

Part "C" %Above / Below _____ Total Amount _____

Total "A+B+C" _____

CONTRACTOR

[Signature]
EXECUTIVE ENGINEER
 EDUCATION WORK DIVISION,
 SHIKARPUR

[Signature]
 Total:- **23432**

BIDDING DATA

(This section should be filled in by the Engineer/Procuring Agency before issuance of the Bidding Documents).

(a). **Name of Procuring Agency:-** Executive Engineer (Education Works)
Division Shikarpur.

DISTRICT ADP SCHEMES (Electrical Works)

(b). **Brief Description of Works:-** ADP 2343 REHABILITATION OF EXISTING BUILDING FOR BOYS / GIRLS PRIMARY ELEMENTARY SCHOOL OF DISTRICT SHIKARPUR TALUKA LAKHI (2013-14) PROGRAMME.

GGPS HABIB KOT

(c). **Procuring Agency's address:-** Executive Engineer (Education Works) Division Shikarpur
Near GBHS No.II Shikarpur.

(d). **Estimated Cost:-** 0.100 (Millions).

(e). **Amount of Bid Security:-** 2% (Fill in lump sum amount or in % age of bid amount /estimated cost, but not exceeding 5%)

(f). **Period of Bid Validity (days):-** 60 Days (Not more than sixty days).

(g). **Security Deposit:-(including bid security):-** 10%
(ir % age of bid amount /estimated cost equal to 10%)

(h). **Percentage, if any, to be deducted from bills:-** 7.50% Income tax

(i). **Deadline for Submission of Bids along with time :-** As Per NIT

(j). **Venue, Time, and Date of Bid Opening:-** Near GBHS II (Shikarpur As Per NIT).

(k). **Time for Completion from written order of commence: -** 06 Months

(L). **Liquidity damages:-** -NIL- (0.05 of Estimated Cost or Bid cost per day of delay, but total not exceeding 10%).

(m). **Deposit Receipt No:** _____ **Date:** _____ **Amount:Rs:** _____

Bank _____

(n) **D.R.NO:** _____ **DATED:** _____ **Amount 500/-**-(Rupees: Five Hundred only).

(o). **Tender issued to Mr. / M/s** _____ **Govt. Contractor.**

EXECUTIVE ENGINEER
EDUCATION WORKS DIVISION
SHIKARPUR

(SCHEDULE (B))

**NAME OF WORK:- REHABILITATION OF EXISTING BUILDING FOR BOYS / GIRLS
PRIMARY / ELEMENTARY SCHOOLS OF DISTRICT SHIKARPUR (2013-14 PROG:)
AT GGPS HABIB KOT TALUKA LAKHI. ADP # 2343 (ELECTRIFICATION)**

S.NO:	Description	Qty	Rate	Unit	Amount
Part "A" Schedule Items					
1	Wiring for light or fan point with 3/.029 PVCinsulated wire in 20mm (3/4") channel patti on surface as required (S.No. 129 P-15).	25	910	per point	22750
2	Wiring for plug point with 3/.029 PVC insulated wire in 20mm (3/4") channel patti on surface as required (S.I.No:130 P- No:15)	4	742	per point	2968
3	Providing & laying (MAIN or SUB MAIN) PVC insulated with size 2-7/.029 copper conductor in 3/4" dia PVC conduit on surface (S.I.No:3 P- No:1)	55	171	P.Mtr	9405
4	Providing & fixing one way SP 5amp switch flush type(S.I.No:219 P- No:33)	25	54	P.No	1350
5	Providing & fixing two pin 5amp plug & socket (S.I.No:225 P- No:33)	4	83	P.No	332
6	Providing & fixing 3pin 10/15amp plug & socket flush type (S.I.No:222 P- No:33)	2	151	P.No	302
7	Providing & fixing circuit breaker 6,10,15,20, 30,40,50 & 63amp SP (TB-5S) on prepared board as required (S.I.No:202 P- No:30)	5	916	P.No	4580
8	Providing & fixing circuit breaker 6,10,15,20, 30,40,50 & 63amp DP (TB-5S) on prepared board as required. (S.I.No:202 P- No:30)	1	2456	P.No	2456
9	Providing & fixing Bakelite ceiling rose with two terminals (S.I.No:228 P- No:33)	12	72	P.No	864
10	Providing & fixing Brass Battern holder (S.I.No:232 P- No:33)	9	70	P.No	630
11	Providing & fixing Brass Ceiling fan 56" (good quality) (S.I.No:235 P- No:34)	8	3185	P.No	25480
12	Providing & laying (MAIN or SUB MAIN) PVC insulated with size 2-7/.052 (10 mm ²) copper conductor in 1" dia PVC conduit on surface (S.I.No:6 P- No:1).	30	428	per Meter	12840
Total:-					83957

S.NO:	Description	Qty	Rate	Unit	Amount
Part "B" Old Schedule Items 2004					
1	P/F d strribution metal board double shutter to accommodate circuit breakers including painting with enemel paint and for other simmlar job on surface (S.I.No:5 P- No:13)	1	907.96	Each	908
2	P/F m ld steel bar fan clamp 15.8 mm (5/8")dia suitable for RCC roof (S.I.No:1 (c) P- No:14)	8	141.01	Each	1128
3	P/F 1-10 walts tube light complete with 40 wats4.0" long rod chok , starter and putty with Phillips components including necessary electric connection and fixingon wall or ceilling etc complete. (S.I.No:1 P- No:33)	4	396.00	Each	1584
4	P/F wall bracket light fancy type superior quality I/n necessary electric connection and fixing on wall or ceilling etc complete (S.I.No:5 P- No:33)	4	497.00	Each	1988
5	P/F Energy sever superior quality I/c fixing on existing holder etc complete (S.I.No:6 P- No:33)	6	497.00	Each	2982
6	P/F bulbs 100 walts (S.I.No:7 P- No:33)	3	25.00	Each	75
7	P/F A.C ceiling fan regulator on metal board recessed in the walls column and covered with plastic sheet (S.I.No:2b P- No:14)	8	124.30	Each	994
8	P/F earthing set with 2x2x1/4" cooper plate burried in groud at a depth of 12" or less if water comes out from the ground level with salt and chorcoal ,etc,in/c.making the pit 12"deep by excavation of all type of soil. Ea th plat to be connected with No:8	1	3610.04	Each	3610

Total:- 13269

[Signature]
DRAUGHTSMAN
EDUCATION WORKS DIVISION
SHIKARPUR.

[Signature]
EXECUTIVE ENGINEER
EDUCATION WORKS DIVISION
SHIKARPUR.

TOTAL (CSR:)

Part "A" %Above / Below _____ Total Amount _____

Part "B" %Above / Below _____ Total Amount _____

Part "C" %Above / Below _____ Total Amount _____

Total "A+B+C" _____

CONTRACTOR

EXECUTIVE ENGINEER
EDUCATION WORK DIVISION,
SHIKARPUR

BIDDING DATA

(This section should be filled in by the Engineer/Procuring Agency before issuance of the Bidding Documents).

(a). Name of Procuring Agency:- Executive Engineer (Education Works)
Division Shikarpur.

DISTRICT ADP SCHEMES (Electrical Works)

(b). Brief Description of Works:- ADP 2347 REHABILITATION OF EXISTING BUILDING FOR BOYS / GIRLS PRIMARY ELEMENTARY SCHOOL OF DISTRICT SHIKARPUR TALUKA KHANPUR (2013-14) PROGRAMME.

1.GBPS AYOUB HAKRO

(c).Procuring Agency's address:-Executive Engineer (Education Works) Division Shikarpur
Near GBHS No.II Shikarpur.

(d). Estimated Cost:- 0.070 (Millions).

(e). Amount of Bid Security:- 2% (Fill in lump sum amount or in % age of bid amount /estimated cost, but not exceeding 5%)

(f).Period of Bid Validity (days):- 60 Days (Not more than sixty days).

(g).Security Deposit:-(including bid security):- 10%
(in % age of bid amount /estimated cost equal to 10%)

(h). Percentage, if any, to be deducted from bills:- 7.50% Income tax

(i). Deadline for Submission of Bids along with time :- As Per NIT

(j). Venue, Time, and Date of Bid Opening:- Near GBHS II (Shikarpur As Per NIT).

(k). Time for Completion from written order of commence: - 06 Months

(L).Liquidity damages:- -NIL- (0.05 of Estimated Cost or Bid cost per day of delay, but total not exceeding 10%).

(m). Deposit Receipt No: _____ Date: _____ Amount:Rs: _____
Bank _____

(n) D.R.NO: _____ DATED: _____ Amount 500/- (Rupees: Five Hundred only).

(o). Tender issued to Mr. / M/s _____ Govt Contractor.

EXECUTIVE ENGINEER
EDUCATION WORKS DIVISION
SHIKARPUR

(SCHEDULE (B))

**NAME OF WORK:- REHABILITATION OF EXISTING BUILDING FOR BOYS / GIRLS
PRIMARY / ELEMENTARY SCHOOLS OF DISTRICT SHIKARPUR (2013-14 PROG:)
AT GBPS AYOUB HAKRO TALUKA KHANPUR. ADP # 2347 (ELECTRIFICATION)**

S.NO:	Description	Qty	Rate	Unit	Amount
Part "A" Schedule Items					
1	Wiring for light or fan point with 3/029 PVCinsulated wire in 20mm (3/4") channel patti on surface as required (S.No. 129 P-15).	19	910	per point	17290
2	Wiring for plug point with 3/029 PVC insulated wire in 20mm (3/4") channel patti on surface as required (S.I.No:130 P- No:15)	4	742	per point	2968
3	Providing & laying (MAIN or SUB MAIN) PVC insulated with size 2.7/029 copper conductor in 3/4" dia PVC conduit on surface (S.I.No:3 P- No:1)	40	171	P.Mtr	6840
4	Providing & fixing one way SP 5amp switch flush type(S.I.No:219 P- No:33)	19	54	P.No	1026
5	Providing & fixing two pin 5amp plug & socket (S.I.No:225 P- No:33)	4	83	P.No	332
6	Providing & fixing 3pin 10/15amp plug & socket flush type (S.I.No:222 P- No:33)	2	151	P.No	302
7	Providing & fixing circuit breaker 6,10,15,20, 30,40,50 & 63amp SP (TB-5S) on prepared board as required (S.I.No:202 P- No:30)	5	916	P.No	4580
8	Providing & fixing circuit breaker 6,10,15,20, 30,40,50 & 63amp DP (TB-5S) on prepared board as required. (S.I.No:202 P- No:30)	1	2456	P.No	2456
9	Providing & fixing Bakelite ceiling rose with two terminals (S.I.No:228 P- No:33)	12	72	P.No	864
10	Providing & fixing Brass Battern holder c(S.I.No:232 P- No:33)	9	70	P.No	630
11	Providing & fixing Brass Ceiling fan 56" (good quality) (S.I.No:235 P- No:34)	4	3185	P.No	12740
12	Providing & laying (MAIN or SUB MAIN) PVC insulated with size 2.7/052 (10 mm ²) copper conductor in 1" dia PVC conduit on surface (S.I.No:6 P- No:1).	12	428	per Meter	5136
Total:-					55164

S.NO:	Description	Qty	Rate	Unit	Amount
Part' B" Old Schedule Items 2004					
1	P/F distribution metal board double shutter to accommodate circuit breakers including painting with enamel paint and for other similar job on surface (S.I.No:5 P- No:13)	1	907.96	Each	908
2	P/F mild steel bar fan clamp 15.8 mm (5/8") dia suitable for RCC roof (S.I.No:1 (c) P- No:14)	8	141.01	Each	1128
3	P/F 1-10 watts tube light complete with 40 watts 4.0" long rod chok , starter and putty with Phillips components including necessary electric connection and fixing on wall or ceiling etc complete. (S.I.No:1 P- No:33)	2	396.00	Each	792
4	P/F wall bracket light fancy type superior quality I/n necessary electric connection and fixing on wall or ceiling etc complete (S.I.No:5 P- No:33)	4	497.00	Each	1988
5	P/F Energy sever superior quality I/c fixing on existing holder etc complete (S.I.No:6 P- No:33)	6	497.00	Each	2982
6	P/F bulbs 100 watts (S.I.No:7 P- No:33)	3	25.00	Each	75
7	P/F A.C ceiling fan regulator on metal board recessed in the walls column and covered with plastic sheet (S.I.No:2b P- No:14)	8	124.30	Each	994
8	P/F earth ring set with 2x2x1/4" cooper plate buried in ground at a depth of 12" or less if water comes out from the ground level with salt and chorcoa ,etc,in/c.making the pit 12" deep by excavation of all type of soil. Earth plat to be connected with No:8	1	3610.04	Each	3610

Total:- 12477

Muhammad
DEAUGHTSMAN
 EDUCATION WORKS DIVISION
 SHIKARPUR.

[Signature]
EXECUTIVE ENGINEER
 EDUCATION WORKS DIVISION
 SHIKARPUR.

TOTAL (CSR:)

Part "A" %Above / Below _____ Total Amount _____
 Part "B" %Above / Below _____ Total Amount _____
 Part "C" %Above / Below _____ Total Amount _____
 Total "A+B+C" _____

CONTRACTOR

EXECUTIVE ENGINEER
 EDUCATION WORK DIVISION,
 SHIKARPUR

BIDDING DATA

(This section should be filled in by the Engineer/Procuring Agency before issuance of the Bidding Documents).

(a). **Name of Procuring Agency:-** Executive Engineer (Education Works)
Division Shikarpur.

DISTRICT ADP SCHEMES (Electrical Works)

(b). **Brief Description of Works:-** ADP 2347 REHABILITATION OF EXISTING BUILDING FOR BOYS / GIRLS PRIMARY ELEMENTARY SCHOOL OF DISTRICT SHIKARPUR TALUKA KHANPUR (2013-14) PROGRAMME.

GBPS IMAMUDDIN BROHI

(c). **Procuring Agency's address:-** Executive Engineer (Education Works) Division Shikarpur
Near GBHS No.II Shikarpur.

(d). **Estimated Cost:-** 0.070 (Millions).

(e). **Amount of Bid Security:-** 2% (Fill in lump sum amount or in % age of bid amount /estimated cost, but not exceeding 5%)

(f). **Period of Bid Validity (days):-** 60 Days (Not more than sixty days).

(g). **Security Deposit:-(including bid security):-** 10%
(in % age of bid amount /estimated cost equal to 10%)

(h). **Percentage, if any, to be deducted from bills:-** 7.50% Income tax

(i). **Deadline for Submission of Bids along with time :-** As Per NIT

(j). **Venue, Time, and Date of Bid Opening:-** Near GBHS II (Shikarpur As Per NIT).

(k). **Time for Completion from written order of commence: -** 06 Months

(L). **Liquidity damages:-** -NIL- (0.05 of Estimated Cost or Bid cost per day of delay, but total not exceeding 10%).

(m). **Deposit Receipt No:** _____ **Date:** _____ **Amount:Rs:** _____

Bank _____

(n) **D.R.NO:** _____ **DATED:** _____ **Amount 500/- (Rupees: Five Hundred only).**

(o). **Tender issued to Mr. / M/s** _____ **Govt: Contractor.**

EXECUTIVE ENGINEER
EDUCATION WORKS DIVISION
SHIKARPUR

(SCHEDULE (B)).

**NAME OF WORK:- REHABILITATION OF EXISTING BUILDING FOR BOYS / GIRLS
PRIMARY / ELEMENTARY SCHOOLS OF DISTRICT SHIKARPUR (2013-14 PROG:)
AT GBPS IMAMUDDIN BROHI TALUKA KHANPUR. ADP # 2347
(ELECTRIFICATION)**

S.NO:	Description	Qty	Rate	Unit	Amount
Part"A" Schedule Items					
1	Wiring for light or fan point with 3/029 PVCinsulated wire in 20mm (3/4") channel patti on surface as required (S.No. 129 P-15).	19	910	per point	17290
2	Wiring for plug point with 3/029 PVC insulated wire in 20mm (3/4") channel patti on surface as required (S.I.No:130 P- No:15)	4	742	per point	2968
3	Providing & laying (MAIN or SUB MAIN) PVC insulated with size 2-7/029 copper conductor in 3/4" dia PVC conduit on surface (S.I.No:3 P- No:1)	40	171	P.Mtr	6840
4	Providing & fixing one way SP 5amp switch flush type(S.I.No:219 P- No:33)	19	54	P.No	1026
5	Providing & fixing two pin 5amp plug & socket (S.I.No:225 P- No:33)	4	83	P.No	332
6	Providing & fixing 3pin 10/15amp plug & socket flush type (S.I.No:222 P- No:33)	2	151	P.No	302
7	Providing & fixing circuit breaker 6,10,15,20, 30,40,50 & 63amp SP (TB-5S) on prepared board as required (S.I.No:202 P- No:30)	5	916	P.No	4580
8	Providing & fixing circuit breaker 6,10,15,20, 30,40,50 & 63amp DP (TB-5S) on prepared board as required. (S.I.No:202 P- No:30)	1	2456	P.No	2456
9	Providing & fixing Bakelite ceiling rose with two terminals (S.I.No:228 P- No:33)	12	72	P.No	864
10	Providing & fixing Brass Battern holder c(S.I.No:232 P- No:33)	9	70	P.No	630
11	Providing & fixing Brass Ceiling fan 56" (good quality) (S.I.No:235 P- No:34)	4	3185	P.No	12740
12	Providing & laying (MAIN or SUB MAIN) PVC insulated with size 2-7/052 (10 mm ²) copper conductor in 1" dia PVC conduit on surface (S.I.No:6 P- No:1).	12	428	per Meter	5136

Total:- 55164

S.NO:	Description	Qty	Rate	Unit	Amount
Part "B" Old Schedule Items 2004					
1	P/F distribution metal board double shutter to accommodate circuit breakers including painting with enamel paint and for other simmlar job on surface (S.I.No:5 P- No:13)	1	907.96	Each	908
2	P/F mild steel bar fan clamp 15.8 mm (5/8")dia suitable for RCC roof (S.I.No:1 (c) P- No:14)	8	141.01	Each	1128
3	P/F 1-40 walts tube light complete with 40 wats4.0" long rod chok , starter and putty with Phillips components including necessary electric connection and fixingon wall or ceiling etc complete. (S.I.No:1 P- No:3)	2	396.00	Each	792
4	P/F wall bracket light fancy type superior quality I/n necessary electric connection and fixing on wall or ceiling etc complete (S.I.No:5 P- No:33)	4	497.00	Each	1988
5	P/F Energy sever superior quality I/c fixing on existing holder etc complete (S.I.No:6 P- No:33)	6	497.00	Each	2982
6	P/F bu bs 100 walts (S.I.No:7 P- No:33)	3	25.00	Each	75
7	P/F A.C ceiling fan regulator on metal board recessed in the walls columr and covered with plastic sheet (S.I.No:2b P- No:14)	8	124.30	Each	994
8	P/F ear hing set with 2x2x1/4" cooper plate burried in groud at a depth of 12" or less if water comes out from the ground level with salt and chorcoal ,etc,in/c.making the pit 12"deep by excavation of all type of soil. Earth plat to be connected with No:8	1	3610.04	Each	3610

[Signature]
DRAUGHTSMAN
 EDUCATION WORKS DIVISION
 SHIKARPUR.

TOTAL (CSR:)

[Signature]
 Total:- 12477

[Signature]
EXECUTIVE ENGINEER
 EDUCATION WORKS DIVISION
 SHIKARPUR.

Part "A" %Above / Below _____ Total Amount _____

Part "B" %Above / Below _____ Total Amount _____

Part "C" %Above / Below _____ Total Amount _____

Total "A+B+C" _____

CONTRACTOR

EXECUTIVE ENGINEER
 EDUCATION WORK DIVISION,
 SHIKARPUR

BIDDING DATA

(This section should be filled in by the Engineer/Procuring Agency before issuance of the Bidding Documents).

(a). **Name of Procuring Agency:-** Executive Engineer (Education Works)
Division Shikarpur.

DISTRICT ADP SCHEMES (Electrical Works)

(b). **Brief Description of Works:-** ADP 2348 REHABILITATION OF EXISTING BUILDING FOR BOYS / GIRLS PRIMARY ELEMENTARY SCHOOL OF DISTRICT SHIKARPUR TALUKA KHANPUR (2013-14) PROGRAMME.

1. GGPS MAZARJO

(c). **Procuring Agency's address:-** Executive Engineer (Education Works) Division Shikarpur
Near GBHS No.II Shikarpur.

(d). **Estimated Cost:-** 0.070 (Millions).

(e). **Amount of Bid Security:-** 2% (Fill in lump sum amount or in % age of bid amount /estimated cost, but not exceeding 5%)

(f). **Period of Bid Validity (days):-** 60 Days (Not more than sixty days).

(g). **Security Deposit:-(including bid security):-** 10%
(in % age of bid amount /estimated cost equal to 10%)

(h). **Percentage, if any, to be deducted from bills:-** 7.50% Income tax

(i). **Deadline for Submission of Bids along with time :-** As Per NIT

(j). **Venue, Time, and Date of Bid Opening:-** Near GBHS II (Shikarpur As Per NIT).

(k). **Time for Completion from written order of commence: -** 06 Months

(L). **Liquidity damages:-** -NIL- (0.05 of Estimated Cost or Bid cost per day of delay, but total not exceeding 10%).

(m). **Deposit Receipt No:** _____ **Date:** _____ **Amount:Rs:** _____
Bank _____

(n) **D.R.NO:** _____ **DATED:** _____ **Amount 500/-**(Rupees: Five Hundred only).

(o). **Tender issued to Mr. / M/s** _____ **Govt: Contractor.**

EXECUTIVE ENGINEER
EDUCATION WORKS DIVISION
SHIKARPUR

(SCHEDULE (B))

**NAME OF WORK:- REHABILITATION OF EXISTING BUILDING FOR BOYS / GIRLS
PRIMARY / ELEMENTARY SCHOOLS OF DISTRICT SHIKARPUR (2013-14 PROG:)
AT GBPS MAZAR JO TALUKA KHANPUR. ADP # 2347 (ELECTRIFICATION)**

S.NO:	Description	Qty	Rate	Unit	Amount
Part "A" Schedule Items					
1	Wiring for light or fan point with 3/.029 PVCinsulated wire in 20mm (3/4") channel patti on surface as required (S.No. 129 P-15).	19	910	per point	17290
2	Wiring for plug point with 3/.029 PVC insulated wire in 20mm (3/4") channel patti on surface as required (S.I.No:130 P- No:15)	4	742	per point	2968
3	Providing & laying (MAIN or SUB MAIN) PVC insulated with size 2-7/.029 copper conductor in 3/4" dia PVC conduit on surface (S.I.No:3 P- No:1)	30	171	P.Mtr	5130
4	Providing & fixing one way SP 5amp switch flush type(S.I.No:219 P- No:33)	19	54	P.No	1026
5	Providing & fixing two pin 5amp plug & socket (S.I.No:225 P- No:33)	4	83	P.No	332
6	Providing & fixing 3pin 10/15amp plug & socket flush type (S.I.No.222 P- No:33)	2	151	P.No	302
7	Providing & fixing circuit breaker 6,10,15,20, 30,40,50 & 63amp SP (TB-5S) on prepared board as required (S.I.No:202 P- No:30)	4	916	P.No	3664
8	Providing & fixing circuit breaker 6,10,15,20, 30,40,50 & 63amp DP (TB-5S) on prepared board as required. (S.I.No:202 P- No:30)	1	2456	P.No	2456
9	Providing & fixing Bakelite ceiling rose with two terminals (S.I.No:228 P- No:33)	12	72	P.No	864
10	Providing & fixing Brass Battern holder c(S.I.No:232 P- No:33)	9	70	P.No	630
11	Providing & fixing Brass Ceiling fan 56" (good quality) (S.I.No:235 P- No:34)	6	3185	P.No	19110
12	Providing & laying (MAIN or SUB MAIN) PVC insulated with size 2-7/.052 (10 mm ²) copper conductor in 1" dia PVC conduit on surface (S.I.No:6 P- No:1).	12	428	per Meter	5136
Total:-					58908

S.NO:	Description	Qty	Rate	Unit	Amount
Part "B" Old Schedule Items 2004					
1	P/F distribution metal board double shutter to accommodate circuit breakers including painting with enamel paint and for other simmlar job on surface (S.I.No:5 P- No:13)	1	907.96	Each	908
2	P/F mild steel bar fan clamp 15.8 mm (5/8")dia suitable for RCC roof (S.I.No:1 (c) P- No:14)	6	141.01	Each	846
3	P/F 1-40 walts tube light complete with 40 wats4.0" long rod chok , starter and putty with Phillips components including necessary electric conection and fixingon wall or ceilling etc complete. (S.I.No:1 P- No:3)	2	396.00	Each	792
4	P/F wall bracket light fancy type superior quality l/n necessary electric conection and fixing on wall or ceilling etc complete (S.I.No:5 P- No:3)	4	497.00	Each	1988
5	P/F Energy sever superior quality l/c fixing on existing holder etc complete (S.I.No:6 P- No:33)	6	497.00	Each	2982
6	P/F bulbs 100 walts (S.I.No:7 P- No:33)	3	25.00	Each	75
7	P/F A.C ceiling fan regulator on metal board recessed in the walls column and covered with plastic sheet (S.I.No:2b P- No:14)	6	124.30	Each	746
8	P/F earthing set with 2x2x1/4" cooper plate burried in groud at a depth of 12" or less if water comes out from the ground level with salt and chorcoal ,etc,in/c.making the pit 12"deep by excavation of all type of soil. Earth plat to be connected with No:8	1	3610.04	Each	3610

[Signature]
DRAUGHTSMAN
 EDUCATION WORKS DIVISION
 SHIKARPUR.

TOTAL (CSR:)

[Signature]
EXECUTIVE ENGINEER
 EDUCATION WORKS DIVISION
 SHIKARPUR.

Total:- 11947

Part "A" %Above / Below _____ Total Amount _____
 Part "B" %Above / Below _____ Total Amount _____
 Part "C" %Above / Below _____ Total Amount _____
 Total "A+B+C" _____

CONTRACTOR

EXECUTIVE ENGINEER
 EDUCATION WORK DIVISION,
 SHIKARPUR

BIDDING DATA

(This section should be filled in by the Engineer/Procuring Agency before issuance of the Bidding Documents).

(a). **Name of Procuring Agency:-** Executive Engineer (Education Works)
Division Shikarpur.

DISTRICT ADP SCHEMES (Electrical Works)

(b). **Brief Description of Works:-** ADP 2327 REHABILITATION OF EXISTING BUILDING
FOR BOYS / GIRLS SECONDARY/HIGHER SECONDARY
SCHOOLS OF DISTRICT & TALUKA SHIKARPUR
(2013-14) PROGRAMME.

GBHS JAGAN

(c). **Procuring Agency's address:-** Executive Engineer (Education Works) Division Shikarpur
Near GBHS No.II Shikarpur.

(c). **Estimated Cost:-** 0.200 (Millions).

(e). **Amount of Bid Security:-** 2% (Fill in lump sum amount or in % age of bid amount /estimated cost, but not exceeding 5%)

(f). **Period of Bid Validity (days):-** 60 Days (Not more than sixty days).

(g). **Security Deposit:-(including bid security):-** 10%
(ir % age of bid amount /estimated cost equal to 10%)

(h). **Percentage, if any, to be deducted from bills:-** 7.50% Income tax

(i) **Deadline for Submission of Bids along with time :-** As Per NIT

(j). **Venue, Time, and Date of Bid Opening:-** Near GBHS II (Shikarpur As Per NIT).

(k). **Time for Completion from written order of commence: -** 06 Months

(L). **Liquidity damages:-** -NIL- (0.05 of Estimated Cost or Bid cost per day of delay, but total not exceeding 10%).

(m). **Deposit Receipt No:** _____ **Date:** _____ **Amount:Rs:** _____
Bank _____

(n) **D.R.NO:** _____ **DATED:** _____ **Amount 500/- (Rupees: Five Hundred only).**

(o). **Tender issued to Mr. / M/s** _____ **Govt: Contractor.**

EXECUTIVE ENGINEER
EDUCATION WORKS DIVISION
SHIKARPUR

(SCHEDULE (B))

NAME OF WORK:- REHABILITATION OF EXISTING BUILDING FOR BOYS / GIRLS SECONDARY / HIGHER SECONDARY SCHOOLS OF DISTRICT & TALUKA SHIKARPUR (2013-14 PROG;) AT GBHS JAGAN SHIKARPUR. ADP # 2327 (ELECTRIFICATION)

S.NO:	Description	Qty	Rate	Unit	Amount
Part "A" Schedule Items					
1	Wiring for light or fan point with 3/0.29 PVC insulated wire in 20mm (3/4") channel patti on surface as required (S.No. 129 P-15).	50	910	per point	45500
2	Wiring for plug point with 3/0.29 PVC insulated wire in 20mm (3/4") channel patti on surface as required (S.I.No:130 P- No:15)	10	742	per point	7420
3	Providing & laying (MAIN or SUB MAIN) PVC insulated with size 2-7/0.29 copper conductor in 3/4" dia PVC conduit on surface (S.I.No:3 P- No:1)	150	171	P.Mtr	25650
4	Providing & laying (MAIN or SUB MAIN) PVC insulated with size 2-7/0.36 (4mm ²) copper conductor in 3/4" dia PVC conduit on surface (S.I.No:4 P- No:1).	55	200	P.Mtr	11000
5	Providing & fixing one way SP 5amp switch flush type(S.I.No:219 P- No:33)	50	54	P.No	2700
6	Providing & fixing two pin 5amp plug & socket (S.I.No:225 P- No:33)	10	83	P.No	830
7	Providing & fixing 3pin 10/15amp plug & socket flush type (S.I.No:222 P- No:33)	1	151	P.No	151
9	Providing & fixing circuit breaker 6,10,15,20, 30,40,50 & 63amp SP (TB-5S) on prepared board as required (S.I.No:202 P- No:30)	7	916	P.No	6412
10	Providing & fixing circuit breaker 6,10,15,20, 30,40,50 & 63amp DP (TB-5S) on prepared board as required. (S.I.No:202 P- No:30)	2	2456	P.No	4912
11	Providing & fixing Bakelite ceiling rose with two terminals (S.I.No:228 P- No:33)	15	72	P.No	1080
12	Providing & fixing Brass Battern holder c(S.I.No:232 P- No:33)	24	70	P.No	1680
13	Providing & fixing Brass Ceiling fan 56" (good quality) (S.I.No:235 P- No:34)	15	3185	P.No	47775
14	Providing & laying (MAIN or SUB MAIN) PVC insulated with size 2-7/0.52 (10 mm ²) copper conductor in 1" dia PVC conduit on surface (S.I.No:6 P- No:1).	40	428	per Meter	17120

Total:- 172230

S.NO:	Description	Qty	Rate	Unit	Amount
Part "B" Old Schedule Items 2004					
1	P/F distribution metal board double shutter to accommodate circuit breakers including painting with enamel paint and for other similar job on surface (S.I.No:5 P- No:13)	1.5	907.96	Each	1362
2	P/F mild steel bar fan clamp 15.8 mm (5/8") dia suitable for RCC roof (S.I.No:1 (c) P- No:14)	15	141.01	Each	2115
3	P/F 1-4) waltz tube light complete with 40 wats 4.0" long rod chok , starter and putty with Phillips components including necessary electric connect on and fixing on wall or ceilling etc complete. (S.I.No:1 P- No:33)	5	396.00	Each	1980
4	P/F wall bracket light fancy type superior quality I/n necessary electric connect on and fixing on wall or ceilling etc complete (S.I.No:5 P- No:33)	6	497.00	Each	2982
5	P/F Energy sever superior quality I/c fixing on existing holder etc complete (S.I.No:6 P- No:33)	19	497.00	Each	9443
6	P/F bulbs 100 waltz (S.I.No:7 P- No:33)	3	25.00	Each	75
7	P/F A.C ceiling fan regulator on metal board recessed in the walls column and covered with plastic sheet (S.I.No:2b P- No:14)	15	124.30	Each	1864.5
8	P/F earthing set with 2x2x1/4" cooper plate burried in groud at a depth of 12" or less if water comes out from the ground level with salt and chorcoa ,etc,in/c.making the pit 12" deep by excavation of all type of soil. Earth plat to be connected with No:8	1	3610.04	Each	3610

M. S. G.
DRAUGHTSMAN
 EDUCATION WORKS DIVISION
 SHIKARPUR.

[Signature]
EXECUTIVE ENGINEER
 EDUCATION WORKS DIVISION
 SHIKARPUR.

Total:- 23432

TOTAL (CSR:)

Part "A" %Above / Below _____ Total Amount _____

Part "B" %Above / Below _____ Total Amount _____

Part "C" %Above / Below _____ Total Amount _____

Total "A+B+C" _____

CONTRACTOR

EXECUTIVE ENGINEER
 EDUCATION WORK DIVISION,
 SHIKARPUR

BIDDING DATA

(This section should be filled in by the Engineer/Procuring Agency before issuance of the Bidding Documents).

(a). **Name of Procuring Agency:-** Executive Engineer (Education Works)
Division Shikarpur.

DISTRICT ADP SCHEMES (Electrical Works)

(b). **Brief Description of Works:-** ADP 2332 REHABILITATION OF EXISTING BUILDING
FOR BOYS / GIRLS SECONDARY/HIGHER SECONDARY
SCHOOLS OF DISTRICT SHIKARPUR TALUKA G.YASIN
(2013-14) PROGRAMME.

GGHSS GARHI YASIN

(c). **Procuring Agency's address:-** Executive Engineer (Education Works) Division Shikarpur
Near GBHS No.II Shikarpur.

(d). **Estimated Cost:-** 0.200 (Millions).

(e). **Amount of Bid Security:-** 2% (Fill in lump sum amount or in % age of bid amount /estimated cost, but not exceeding 5%)

(f). **Period of Bid Validity (days):-** 60 Days (Not more than sixty days).

(g). **Security Deposit:-(including bid security):-** 10%
(in % age of bid amount /estimated cost equal to 10%)

(h). **Percentage, if any, to be deducted from bills:-** 7.50% Income tax

(i). **Deadline for Submission of Bids along with time :-** As Per NIT

(j). **Venue, Time, and Date of Bid Opening:-** Near GBHS II (Shikarpur As Per NIT).

(k). **Time for Completion from written order of commence: -** 06 Months

(L). **Liquidity damages:-** -NIL- (0.05 of Estimated Cost or Bid cost per day of delay, but total not exceeding 10%).

(m). **Deposit Receipt No:** _____ **Date:** _____ **Amount:Rs:** _____
Bank _____

(n) **D.R.NO:** _____ **DATED:** _____ **Amount 500/- (Rupees: Five Hundred only).**

(o). **Tender issued to Mr. / M/s** _____ **Govt: Contractor.**

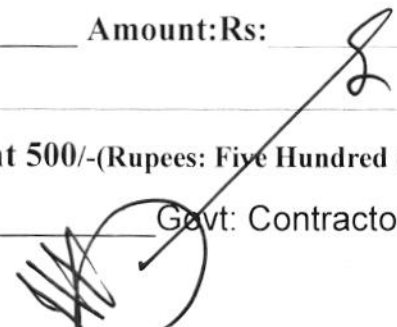
EXECUTIVE ENGINEER
EDUCATION WORKS DIVISION
SHIKARPUR

(SCHEDULE (B)).

NAME OF WORK:- REHABILITATION OF EXISTING BUILDING FOR BOYS / GIRLS SECONDARY / HIGHER SECONDARY SCHOOLS OF DISTRICT & TALUKA SHIKARPUJR (2013-14 PROG:) AT GGHSS GHARI YASIN TALUKA GHARI YASIN. ADP # 2332 (ELECTRIFICATION)

S.NO:	Description	Qty	Rate	Unit	Amount
Part "A" Schedule Items					
1	Wiring for light or fan point with 3/029 PVCinsulated wire in 20mm (3/4") channel patti on surface as required (S.No. 129 P-15).	50	910	per point	45500
2	Wiring for plug point with 3/029 PVC insulated wire in 20mm (3/4") channel patti on surface as required (S.I.No:130 P- No:15)	10	742	per point	7420
3	Providing & laying (MAIN or SUB MAIN) PVC insulated with size 2-7/029 copper conductor in 3/4" dia PVC conduit on surface (S.I.No:3 P- No:1)	150	171	P.Mtr	25650
4	Providing & laying (MAIN or SUB MAIN) PVC insulated with size 2-7/036 (4mm ²) copper conductor in 3/4" dia PVC conduit on surface (S.I.No:4 P- No:1).	55	200	P.Mtr	11000
5	Providing & fixing one way SP 5amp switch flush type(S.I.No:219 P- No:33)	50	54	P.No	2700
6	Providing & fixing two pin 5amp plug & socket (S.I.No:225 P- No:33)	10	83	P.No	830
7	Providing & fixing 3pin 10/15amp plug & socket flush type (S.I.No:222 P- No:33)	1	151	P.No	151
9	Providing & fixing circuit breaker 6,10,15,20, 30,40,50 & 63amp SP (TB-5S) on prepared board as required (S.I.No:202 P- No:30)	7	916	P.No	6412
10	Providing & fixing circuit breaker 6,10,15,20, 30,40,50 & 63amp DP (TB-5S) on prepared board as required. (S.I.No:202 P- No:30)	2	2456	P.No	4912
11	Providing & fixing Bakelite ceiling rose with two terminals (S.I.No:228 P- No:33)	15	72	P.No	1080
12	Providing & fixing Brass Battern holder c(S.I.No:232 P- No:33)	24	70	P.No	1680
13	Providing & fixing Brass Ceiling fan 56" (good quality) (S.I.No:235 P- No:34)	15	3185	P.No	47775
14	Providing & laying (MAIN or SUB MAIN) PVC insulated with size 2-7/052 (10 mm ²) copper conductor in 1" dia PVC conduit on surface (S.I.No:6 P- No:1).	40	428	per Meter	17120
Total:-					172230

S.NO:	Description	Qty	Rate	Unit	Amount
Part "B" Old Schedule Items 2004					
1	P/F distribution metal board double shutter to accommodate circuit breakers including painting with enamel paint and for other similar job on surface (S.I.No:5 P- No:13)	1.5	907.96	Each	1362
2	P/F mild steel bar fan clamp 15.8 mm (5/8") dia suitable for RCC roof (S.I.No:1 (c) P- No:14)	15	141.01	Each	2115
3	P/F 40 wats tube light complete with 40 wats 4.0" long rod chok , starter and putty with Phillips components including necessary electric connection and fixing on wall or ceiling etc complete. (S.I.No:1 P- No:33)	5	396.00	Each	1980
4	P/F wall bracket light fancy type superior quality I/n necessary electric connection and fixing on wall or ceiling etc complete (S.I.No:5 P- No:33)	6	497.00	Each	2982
5	P/F Energy sever superior quality I/c fixing on existing holder etc complete (S.I.No:6 P- No:33)	19	497.00	Each	9443
6	P/F bu bs 100 wats (S.I.No:7 P- No:33)	3	25.00	Each	75
7	P/F A.C ceiling fan regulator on metal board recessed in the walls column and covered with plastic sheet (S.I.No:2b P- No:14)	15	124.30	Each	1864.5
8	P/F earthing set with 2x2x1/4" cooper plate burried in groud at a depth of 12" or less if water comes out from the ground level with salt and chorcoa ,etc,in/c.making the pit 12" deep by excavation of all type of soil. Ear:h plat to be connected with No:8	1	3610.04	Each	3610

M. S. S.
DRAUGHTSMAN
EDUCATION WORKS DIVISION
SHIKARPUR.

[Signature]
Total:- 23432

[Signature]
EXECUTIVE ENGINEER
EDUCATION WORKS DIVISION
SHIKARPUR.

TOTAL (CSR:)

Part "A" %Above / Below _____ Total Amount _____

Part "B" %Above / Below _____ Total Amount _____

Part "C" %Above / Below _____ Total Amount _____

Total "A+B+C" _____

CONTRACTOR

EXECUTIVE ENGINEER
EDUCATION WORK DIVISION,
SHIKARPUR

BIDDING DATA

(This section should be filled in by the Engineer/Procuring Agency before issuance of the Bidding Documents).

(a). **Name of Procuring Agency:-** Executive Engineer (Education Works)
Division Shikarpur.

DISTRICT ADP SCHEMES (Electrical Works)

(b). **Brief Description of Works:-** ADP 2333 REHABILITATION OF EXISTING BUILDING FOR BOYS / GIRLS SECONDARY/HIGHER SECONDARY SCHOOLS OF DISTRICT SHIKARPUR TALUKA G.YASIN (2013-14) PROGRAMME.

GBHS PANHWAR BHUTTA

(c). **Procuring Agency's address:-** Executive Engineer (Education Works) Division Shikarpur
Near GBHS No.II Shikarpur.

(d). **Estimated Cost:-** 0.150 (Millions).

(e). **Amount of Bid Security:-** 2% (Fill in lump sum amount or in % age of bid amount /estimated cost, but not exceeding 5%)

(f). **Period of Bid Validity (days):-** 60 Days (Not more than sixty days).

(g) **Security Deposit:-(including bid security):-** 10%
(in % age of bid amount /estimated cost equal to 10%)

(h). **Percentage, if any, to be deducted from bills:-** 7.50% Income tax

(i). **Deadline for Submission of Bids along with time :-** As Per NIT

(j). **Venue, Time, and Date of Bid Opening:-** Near GBHS II (Shikarpur As Per NIT).

(k). **Time for Completion from written order of commence: -** 06 Months

(L). **Liquidity damages:-** -NIL- (0.05 of Estimated Cost or Bid cost per day of delay, but total not exceeding 10%).

(m). **Deposit Receipt No:** _____ **Date:** _____ **Amount:Rs:** _____

Bank: _____

(n) **D.R.NO:** _____ **DATED:** _____ **Amount 500/-**(Rupees: Five Hundred only).

(o). **Tender issued to Mr. / M/s** _____ **Govt:** Contractor.

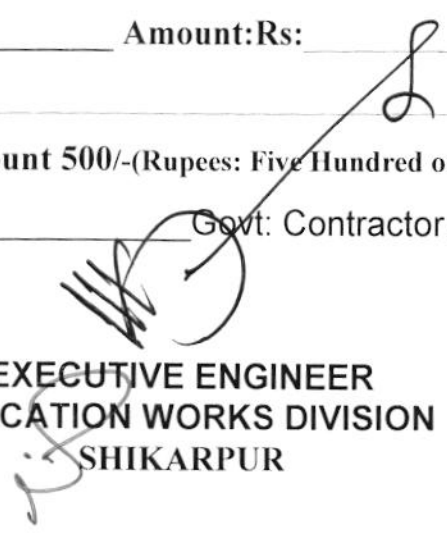
EXECUTIVE ENGINEER
EDUCATION WORKS DIVISION
SHIKARPUR



(SCHEDULE (B))

NAME OF WORK:- REHABILITATION OF EXISTING BUILDING FOR BOYS / GIRLS SECONDARY / HIGHER SECONDARY SCHOOLS OF DISTRICT SHIKARPUR (2013-14 PROG:) AT GBHS PANHWAR BHUTTA TALUKA GHARI YASIN. ADP # 2333 (ELECTRIFICATION)

S.NO:	Description	Qty	Rate	Unit	Amount
Part "A" Schedule Items					
1	Wiring for light or fan point with 3/.029 PVC insulated wire in 20mm (3/4") channel patti on surface as required (S.No. 129 P-15).	44	910	per point	40040
2	Wiring for plug point with 3/.029 PVC insulated wire in 20mm (3/4") channel patti on surface as required (S.I.No:130 P- No:15)	8	742	per point	5936
3	Providing & laying (MAIN or SUB MAIN) PVC insulated with size 2-7/.029 copper conductor in 3/4" dia PVC conduit on surface (S.I.No:3 P- No:1)	100	171	P.Mtr	17100
4	Providing & laying (MAIN or SUB MAIN) PVC insulated with size 2-7/.026 (4mm ²) copper conductor in 3/4" dia PVC conduit on surface (S.I.No:4 P- No:1).	30	200	P.Mtr	6000
5	Providing & fixing one way SP 5amp switch flush type(S.I.No:219 P- No:33)	44	54	P.No	2376
6	Providing & fixing two pin 5amp plug & socket (S.I.No:225 P- No:33)	8	83	P.No	664
7	Providing & fixing 3pin 10/15amp plug & socket flush type (S.I.No:222 P- No:33)	1	151	P.No	151
9	Providing & fixing circuit breaker 6,10,15,20, 30,40,50 & 63amp SP (TB-5S) on prepared board as required (S.I.No:202 P- No:30)	7	916	P.No	6412
10	Providing & fixing circuit breaker 6,10,15,20, 30,40,50 & 63amp DP (TB-5S) on prepared board as required. (S.I.No:202 P- No:30)	1	2456	P.No	2456
11	Providing & fixing Bakelite ceiling rose with two terminals (S.I.No:228 P- No:33)	13	72	P.No	936
12	Providing & fixing Brass Battern holder c(S.I.No:232 P- No:33)	24	70	P.No	1680
13	Providing & fixing Brass Ceiling fan 56" (good quality) (S.I.No:235 P- No:34)	12	3185	P.No	38220
14	Providing & laying (MAIN or SUB MAIN) PVC insulated with size 2-7/.052 (10 mm ²) copper conductor in 1" dia PVC conduit on surface (S.I.No:6 P- No:1).	17	428	per Meter	7276

Total:- 129247

S.NO:	Description	Qty	Rate	Unit	Amount
Part "B" Old Schedule Items 2004					
1	P/F d.tribution metal board double shutter to accommodate circuit breakers including painting with enamel paint and for other simmlar job on surface (S.I.No:5 P- No:13)	1.5	907.96	Each	1362
2	P/F mild steel bar fan clamp 15.8 mm (5/8")dia suitable for RCC roof (S.I.No:1 (c) P- No:14)	12	141.01	Each	1692
3	P/F 1-40 walts tube light complete with 40 wats4.0" long rod chok , starter and putty with Phillips components including necessary electric connec ion and fixingon wall or ceilling etc complete. (S.I.No:1 P- No:33)	2	396.00	Each	792
4	P/F wall bracket light fancy type superior quality I/n necessary electric connection and fixing on wall or ceilling etc complete (S.I.No:5 P- No:33)	6	497.00	Each	2982
5	P/F Energy sever superior quality I/c fixing on existing holder etc complete: (S.I.No:6 P- No:33)	10	497.00	Each	4970
6	P/F bulb; 100 walts (S.I.No:7 P- No:33)	14	25.00	Each	350
7	P/F A.C ceiling fan regulator on metal board recessed in the walls column and covered with plastic sheet (S.I.No:2b P- No:14)	12	124.30	Each	1491.6
8	P/F earth ng set with 2x2x1/4" cooper plate burried in groud at a depth of 12" or less if water comes out from the ground level with salt and chorcoal etc,in/c.making the pit 12"deep by excavation of all type of soil. Earth plat to be connected with No:8	1	3610.04	Each	3610

Total: 17250

D RAUGHTSMAN
 EDUCATION WORKS DIVISION
 SHIKARPUR.

EXECUTIVE ENGINEER
 EDUCATION WORKS DIVISION
 SHIKARPUR.

TOTAL (CSR:)

Part "A" %Above / Below _____ Total Amount _____

Part "B" %Above / Below _____ Total Amount _____

Part "C" %Above / Below _____ Total Amount _____

Total "A+B+C" _____

CONTRACTOR

EXECUTIVE ENGINEER
 EDUCATION WORK DIVISION,
 SHIKARPUR

BIDDING DATA

(This section should be filled in by the Engineer/Procuring Agency before issuance of the Bidding Documents).

(a). Name of Procuring Agency:- Executive Engineer (Education Works)
Division Shikarpur.

DISTRICT ADP SCHEMES (Electrical Works)

(b). Brief Description of Works:- ADP 2334 REHABILITATION OF EXISTING BUILDING FOR BOYS / GIRLS SECONDARY/HIGHER SECONDARY SCHOOLS OF DISTRICT SHIKARPUR TALUQA G.YASIN (2013-14) PROGRAMME (03 UNITS).

GGHS DAKHAN

(c). Procuring Agency's address:- Executive Engineer (Education Works) Division Shikarpur
Near GBHS No.II Shikarpur.

(d). Estimated Cost:- 0.200 (Millions).

(e). Amount of Bid Security:- 2% (Fill in lump sum amount or in % age of bid amount /estimated cost, but not exceeding 5%)

(f). Period of Bid Validity (days):- 60 Days (Not more than sixty days)

(g). Security Deposit:-(including bid security):- 10%
(in % age of bid amount /estimated cost equal to 10%)

(h). Percentage, if any, to be deducted from bills:- 7.50% Income tax

(i). Deadline for Submission of Bids along with time :- As Per NIT

(j). Venue, Time, and Date of Bid Opening:- Near GBHS II (Shikarpur As Per NIT).

(k). Time for Completion from written order of commence: - 06 Months

(L). Liquidity damages:- -NIL- (0.05 of Estimated Cost or Bid cost per day of delay, but total not exceeding 10%).

(m). Deposit Receipt No: _____ Date: _____ Amount:Rs: _____

Bank _____

(n) D.R.NO: _____ DATED: _____ Amount 500/- (Rupees: Five Hundred only).

(o). Tender issued to Mr. / M/s _____ Govt Contractor.

EXECUTIVE ENGINEER
EDUCATION WORKS DIVISION
SHIKARPUR

(SCHEDULE (B)).

**NAME OF WORK:- REHABILITATION OF EXISTING BUILDING FOR BOYS / GIRLS
SECONDARY / HIGHER SECONADRY OF DISTRICT SHIKARPUR (2013-14 PROG:)
AT GGHS DAKHAN TALUKA GHARI YASIN. ADP # 2334 (ELECTRIFICATION)**

S.NO:	Description	Qty	Rate	Unit	Amount
Part "A" Schedule Items					
1	Wiring for light or fan point with 3/029 PVC insulated wire in 20mm (3/4" channel patti on surface as required (S.No. 129 P-15).	44	910	per point	40040
2	Wiring for plug point with 3/029 PVC insulated wire in 20mm (3/4" channel patti on surface as required (S.I.No:130 P- No:15)	8	742	per point	5936
3	Providing & laying (MAIN or SUB MAIN) PVC insulated with size 2-7/029 copper conductor in 3/4" dia PVC conduit on surface (S.I.No:3 P- No:1)	150	171	P.Mtr	25650
4	Providing & laying (MAIN or SUB MAIN) PVC insulated with size 2-7/036 (4mm ²) copper conductor in 3/4" dia PVC conduit on surface (S.I.No:4 P- No:1).	80	200	P.Mtr	16000
5	Providing & fixing one way SP 5amp switch flush type(S.I.No:219 P- No:33)	44	54	P.No	2376
6	Providing & fixing two pin 5amp plug & socket (S.I.No:225 P- No:33)	8	83	P.No	664
7	Providing & fixing 3pin 10/15amp plug & socket flush type (S.I.No:222 P- No:33)	1	151	P.No	151
9	Providing & fixing circuit breaker 6,10,15,20, 30,40,50 & 63amp SP (TB-5S) on prepared board as required (S.I.No:202 P- No:30)	6	916	P.No	5496
10	Providing & fixing circuit breaker 6,10,15,20, 30,40,50 & 63amp DP (TB-5S) on prepared board as required. (S.I.No:202 P- No:30)	1	2456	P.No	2456
11	Providing & fixing Bakelite ceiling rose with two terminals (S.I.No:228 P- No:33)	20	72	P.No	1440
12	Providing & fixing Brass Battern holder c(S.I.No:232 P- No:33)	22	70	P.No	1540
13	Providing & fixing Brass Ceiling fan 56" (good quality) (S.I.No:235 P- No:34)	16	3185	P.No	50960
14	Providing & laying (MAIN or SUB MAIN) PVC insulated with size 2-7/052 (10 mm ²) copper conductor in 1" dia PVC conduit on surface (S.I.No:6 P- No:1).	50	428	per Meter	21400

Total:- 174109

S.NO:	Description	Qty	Rate	Unit	Amount
Part "B" Old Schedule Items 2004					
1	P/F distribution metal board double shutter to accommodate circuit breakers including painting with enamel paint and for other similar job on surface (S.I.No:5 P- No:13)	1.5	907.96	Each	1362
2	P/F mild steel bar fan clamp 15.8 mm (5/8") dia suitable for RCC roof (S.I.No:1 (c) P- No:14)	16	141.01	Each	2256
3	P/F 140 watts tube light complete with 40 watts 4.0" long rod chok , starter and putty with Phillips components including necessary electric connection and fixing on wall or ceiling etc complete. (S.I.No:1 P- No:33)	4	396.00	Each	1584
4	P/F wall bracket light fancy type superior quality I/n necessary electric connection and fixing on wall or ceiling etc complete (S.I.No:5 P- No:33)	6	497.00	Each	2982
5	P/F Energy sever superior quality I/c fixing on existing holder etc complete (S.I.No:6 P- No:33)	15	497.00	Each	7455
6	P/F bulbs 100 watts (S.I.No:7 P- No:33)	3	25.00	Each	75
7	P/F A.C ceiling fan regulator on metal board recessed in the walls column and covered with plastic sheet (S.I.No:2b P- No:14)	16	124.30	Each	1989
8	P/F earthing set with 2x2x1/4" cooper plate buried in ground at a depth of 12" or less if water comes out from the ground level with salt and chorcoal ,etc,in/c.making the pit 12" deep by excavation of all type of soil. Ear h plat to be connected with No:8	1	3610.04	Each	3610

Total:- 21313

[Signature]
DI DAUGHTSMAN
 EDUCATION WORKS DIVISION
 SHIKARPUR.

TOTAL (CSR:)

[Signature]
EXECUTIVE ENGINEER
 EDUCATION WORKS DIVISION
 SHIKARPUR.

Part "A"

%Above / Below _____ Total Amount _____

Part "B"

%Above / Below _____ Total Amount _____

Part "C"

%Above / Below _____ Total Amount _____

Total "A+B+C" _____

CONTRACTOR

EXECUTIVE ENGINEER
 EDUCATION WORK DIVISION,
 SHIKARPUR

BIDDING DATA

(This section should be filled in by the Engineer/Procuring Agency before issuance of the Bidding Documents).

(a). **Name of Procuring Agency:-** Executive Engineer (Education Works)
Division Shikarpur.

DISTRICT ADP SCHEMES (Electrical Works)

(b). **Brief Description of Works:-** ADP 2314 REHABILITATION OF GOVERNMENT BOYS
SECONDARY SCHOOLS OF DISTRICT SHIKARPUR
(2010-11) PROGRAMME.

GBHS NO: 1 SHIKARPUR

(c). **Procuring Agency's address:-** Executive Engineer (Education Works) Division Shikarpur
Near GBHS No.II Shikarpur.

(d). **Estimated Cost:-** 0.200 (Millions).

(e). **Amount of Bid Security:-** 2% (Fill in lump sum amount or in % age of bid amount /estimated cost, but not exceeding 5%)

(f). **Period of Bid Validity (days):-** 60 Days (Not more than sixty days).

(g). **Security Deposit:-(including bid security):-** 10%
(in % age of bid amount /estimated cost equal to 10%)

(h). **Percentage, if any, to be deducted from bills:-** 7.50% Income tax

(i). **Deadline for Submission of Bids along with time :-** As Per NIT

(j). **Venue, Time, and Date of Bid Opening:-** Near GBHS II (Shikarpur As Per NIT).

(k). **Time for Completion from written order of commence: -** 06 Months

(L). **Liquidity damages:-** -NIL- (0.05 of Estimated Cost or Bid cost per day of delay, but total not exceeding 10%).

(m). **Deposit Receipt No:** _____ **Date:** _____ **Amount:Rs:** _____

Bank _____

(n) **D.R.NO:** _____ **DATED:** _____ **Amount 500/- (Rupees: Five Hundred only).**

(o). **Tender issued to Mr. / M/s** _____ **Govt: Contractor.**

EXECUTIVE ENGINEER
EDUCATION WORKS DIVISION
SHIKARPUR

BILL OF QUANTITIES

Discription and Rate of Items based on Composite Schedule of Rates

NAME OF WORK :- REHABILITATION OF GOVERNMENT BOYS SECONDARY SCHOOLS OF DISTRICT SHIKARPUR (2010-11 PROG:) AT GBHS NO.1 SHIKARPUR. ADP # 2314 (ELECTRIFICATION)

Item No.	Quantities	Description of item to be executed at site	Rate	Units	Amount
<u>PART "A" SCHEDULE ITEMS</u>					
1	60	Wiring for light or fan point with 3/.029 PVCinsulated wire in 20mm (3/4") channel patti on surface as required (S.No. 129 P-15).	910	per point	54600
2	12	Wiring for plug point with 3/.029 PVC insulated wire in 20mm (3/4") channel patti on surface as required (S.I.No:130 P- No:15)	742	per point	8904
3	100	Providing & laying (MAIN or SUB MAIN) PVC insulated with size 2-7/.029 copper conductor in 3/4" dia PVC conduit on surface (S.I.No:3 P- No:1)	171	P.Mtr	17100
4	20	Providing & laying (MAIN or SUB MAIN) PVC insulated with size 2-7/.036 (4mm ²) copper conductor in 3/4" dia PVC conduit on surface (S.I.No:4 P- No:1):	200	P.Mtr	4000
5	60	Providing & fixing one way SP 5amp switch flush type	54	P.No	3240
6	12	Providing & fixing two pin 5amp plug & socket (S.I.No:225 P- No:33)	83	P.No	996
7	2	Providing & fixing 3pin 10/15amp plug & socket flush type	151	P.No	302
9	12	Providing & fixing circuit breaker 6,10,15,20, 30,40,50 & 63amp SP (TB-5S) on prepared board as required (S.I.No:202 P- No:30)	916	P.No	10992
10	2	Providing & fixing circuit breaker 6,10,15,20, 30,40,50 & 63amp DP (TB-5S) on prepared board as required. (S.I.No:202 P- No:30)	2456	P.No	4912
11	27	Providing & fixing Bakolite coiling rose with two terminals	72	P.No	1944
12	23	Providing & fixing Brass Battern holder c(S.I.No:232 P- No:33)	70	P.No	1610
13	21	Providing & fixing Brass Ceiling fan 56" (good quality) (S.I.No:235 P- No:34)	3185	P.No	66885
14	30	Providing & laying (MAIN or SUB MAIN) PVC insulated with size 2-7/.052 (10 mm ²) copper conductor in 1" dia PVC conduit on surface (S.I.No:6 P- No:1).	428	per Meter	12840
TOTAL :-					188325

<u>PART "B" SCHEDULE ITEMS</u>					
1	3	P/F distribution metal board double shutter to accommodate circuit breakers including painting with enamel paint and for other simmlar job on surface (S.I.No:5 P- No:13)	907.96	Each	2724
2	21	P/F mild steel bar fan clamp 15.8 mm (5/8")dia suitable for RCC roof (S.I.No:1 (c) P- No:14)	141.01	Each	2961
3	6	P/F 1-40 walts tube light complete with 40 wats4.0" long rod chok , starter and putty with Phillips components including necessary electric connection and fixingon wall or ceilling etc complete. (S.I.No:1 P- No:33)	396.00	Each	2376
4	6	P/F wall bracket light fancy type superior quality l/n necessary electric connection and fixing on wall or ceilling etc complete (S.I.No:5 P- No:33)	497.00	Each	2982
5	15	P/F Energy sever superior quality l/c fixing on existing holder etc complete (S.I.No:6 P- No:33)	497.00	Each	7455
6	8	P/F bulbs 100 walts (S.I.No:7 P- No:33)	25.00	Each	200
7	21	P/F A.C ceiling fan regulator on metal board recessed in the walls column and covered with plastic sheet (S.I.No:2b P- No:14)	124.30	Each	2610
8	1	P/F earthing set with 2x2x1/4" cooper plate burried in groud at a depth of 12" or less if water comes out from the ground level with salt and chorcoal .etc.in/c.making the pit 12"deep by excavation of all type of soil. Earth plat to be connected with Nq:8	3610.04	Each	3610
TOTAL :-					24918

Amount Total (CS) **DRA JGHYSMAN**
WORKS DIVISION
SH KARPUR.

EXECUTIVE ENGINEER
EDUCATION WORKS DIVISION
SHIKARPUR.

Part "A" %Above / Below _____ Total Amount _____
Part "B" %Above / Below _____ Total Amount _____
Total "A+B" _____

CONTRACTOR

BIDDING DATA

(This section should be filled in by the Engineer/Procuring Agency before issuance of the Bidding Documents).

- (a). **Name of Procuring Agency:-** Executive Engineer (Education Works)
Division Shikarpur.
- DISTRICT ADP SCHEMES (Electrical Works)**
- (b). **Brief Description of Works:-** ADP 2315 REHABILITATION OF GOVERNMENT BOYS
SECONDARY SCHOOLS OF DISTRICT SHIKARPUR
(2010-11) PROGRAMME.
- GBHS NO: 2 SHIKARPUR
- (c). **Procuring Agency's address:-** Executive Engineer (Education Works) Division Shikarpur
Near GBHS No.II Shikarpur.
- (d). **Estimated Cost:-** 0.200 (Millions).
- (e). **Amount of Bid Security:-** 2% (Fill in lump sum amount or in % age of bid amount /estimated cost, but not exceeding 5%)
- (f). **Period of Bid Validity (days):-** 60 Days (Not more than sixty days).
- (g). **Security Deposit:-(including bid security):-** 10%
(in % age of bid amount /estimated cost equal to 10%)
- (h). **Percentage, if any, to be deducted from bills:-** 7.50% Income tax
- (i). **Deadline for Submission of Bids along with time :-** As Per NIT
- (j). **Venue, Time, and Date of Bid Opening:-** Near GBHS II (Shikarpur As Per NIT).
- (k). **Time for Completion from written order of commence: -** 06 Months
- (L). **Liquidity damages:-** -NIL- (0.05 of Estimated Cost or Bid cost per day of delay, but total not exceeding 10%).
- (m). **Deposit Receipt No:** _____ **Date:** _____ **Amount:Rs:** _____
Bank _____
- (n) **D.R.NO:** _____ **DATED:** _____ **Amount 500/- (Rupees: Five Hundred only).**
- (o). **Tender issued to Mr. / M/s** _____ **Govt. Contractor.**

EXECUTIVE ENGINEER
EDUCATION WORKS DIVISION
SHIKARPUR

(SCHEDULE(B)).

NAME OF WORK:-

REHABILITATION OF GOVERNMENT BOYS SECONDARY SCHOOLS
OF DISTRICT SHIKARPUR (2010-11-PROGRAMME) AT
GBHS NO:2 SHIKARPUR TALUKA & DISTRICT SHIKARPUR.
(ELECTRIFICATION).

S.NO:	Description	Qty	Rate	Unit	Amount
Part "A" Schedule Items					
1	Wiring for light or fan point with 3/029 PVC insulated wire in 20mm (3/4") channel patti on surface as required (S.No. 129 P-15).	50	910	per point	45500
2	Wiring for plug point with 3/029 PVC insulated wire in 20mm (3/4") channel patti on surface as required (S.I.No:130 P- No:15)	10	742	per point	7420
3	Providing & laying (MAIN or SUB MAIN) PVC insulated with size 2-7/02) copper conductor in 3/4" dia PVC conduit on surface (S.I.No:3 P- No:1)	150	171	P.Mtr	25650
4	Providing & laying (MAIN or SUB MAIN) PVC insulated with size 2-7/03) (4mm ²) copper conductor in 3/4" dia PVC conduit on surface (S.I.No:4 P- No:1).	55	200	P.Mtr	11000
5	Providing & fixing one way SP 5amp switch flush type(S.I.No:219 P- No:33)	50	54	P.No	2700
6	Providing & fixing two pin 5amp plug & socket (S.I.No:225 P- No:33)	10	83	P.No	830
7	Providing & fixing 3pin 10/15amp plug & socket flush type (S.I.No:222 P- No:33)	1	151	P.No	151
9	Providing & fixing circuit breaker 6,10,15,20, 30,40,50 & 63amp SP (TB-5S) on prepared board as required (S.I.No:202 P- No:30)	7	916	P.No	6412
10	Providing & fixing circuit breaker 6,10,15,20, 30,40,50 & 63amp DP (TB-5S) on prepared board as required. (S.I.No:202 P- No:30)	2	2456	P.No	4912
11	Providing & fixing Bakelite ceiling rose with two terminals (S.I.No 228 P- No:33)	15	72	P.No	1080
12	Providing & fixing Brass Battern holder c(S.I.No:232 P- No:33)	24	70	P.No	1680
13	Providing & fixing Brass Ceiling fan 56" (good quality) (S.I.No:235 P- No:34)	15	3185	P.No	47775
14	Providing & laying (MAIN or SUB MAIN) PVC insulated with size 2-7/052 (10 mm ²) copper conductor in 1" dia PVC conduit on surface (S.I.No:5 P- No:1).	40	428	per Meter	17120

Total:- 172230

S.NO:	Description	Qty	Rate	Unit	Amount
Part "B" Old Schedule Items 2004					
1	P/F distribution metal board double shutter to accommodate circuit breaker including painting with enamel paint and for other similar job on surface (S.I.No:5 P- No:13)	1.5	907.96	Each	1362
2	P/F mild steel bar fan clamp 15.8 mm (5/8") dia suitable for RCC roof (S.I.No:1 (c) P- No:14)	15	141.01	Each	2115
3	P/F 1-40 wats tube light complete with 40 wats 4.0" long rod chok , starter and putty with Phillips components including necessary electric connection and fixing on wall or ceiling etc complete. (S.I.No:1 P- No:33)	5	396.00	Each	1980
4	P/F wall bracket light fancy type superior quality I/n necessary electric connection and fixing on wall or ceiling etc complete (S.I.No:5 P- No:33)	6	497.00	Each	2982
5	P/F Energy sever superior quality I/c fixing on existing holder etc complete (S.I.No:6 P- No:33)	19	497.00	Each	9443
6	P/F bulbs 100 wats (S.I.No:7 P- No:33)	3	25.00	Each	75
7	P/F A.C ceiling fan regulator on metal board recessed in the walls column and covered with plastic sheet (S.I.No:2b P- No:14)	15	124.30	Each	1864.5
8	P/F earthing set with 2x2x1/4" cooper plate burried in groud at a depth of 12" or less if water comes out from the ground level with salt and chorcoal ,etc,in/c.making the pit 12" deep by excavation of all type of soil. Earth plat to be connected with No:8	1	3610.04	Each	3610

De Aughtsman
DE AUGHTSMAN
 EDUCATION WORKS DIVISION
 SHIKARPUR.

[Signature]
 Total:- 23432

[Signature]
 EXECUTIVE ENGINEER
 EDUCATION WORKS DIVISION
 SHIKARPUR.

TOTAL (CSR:)

Part "A" %Above / Below _____ Total Amount _____

Part "B" %Above / Below _____ Total Amount _____

Part "C" %Above / Below _____ Total Amount _____

Total "A+B+C" _____

CONTRACTOR

EXECUTIVE ENGINEER
 EDUCATION WORK DIVISION,
 SHIKARPUR

BIDDING DATA

(This section should be filled in by the Engineer/Procuring Agency before issuance of the Bidding Documents).

- (a). **Name of Procuring Agency:-** Executive Engineer (Education Works)
Division Shikarpur.
- DISTRICT ADP SCHEMES (Electrical Works)**
- (b). **Brief Description of Works:-** ADP 2320 REHABILITATION OF GOVERNMENT BOYS
SECONDARY SCHOOLS OF DISTRICT SHIKARPUR
(2010-11) PROGRAMME.
- GBHS LAKHI
- (c). **Procuring Agency's address:-** Executive Engineer (Education Works) Division Shikarpur
Near GBHS No.II Shikarpur.
- (d). **Estimated Cost:-** 0.200 (Millions).
- (e). **Amount of Bid Security:-** 2% (Fill in lump sum amount or in % age of bid amount /estimated cost, but not exceeding 5%)
- (f). **Period of Bid Validity (days):-** 60 Days (Not more than sixty days).
- (g). **Security Deposit:-(including bid security):-** 10%
(in % age of bid amount /estimated cost equal to 10%)
- (h). **Percentage, if any, to be deducted from bills:-** 7.50% Income tax
- (i). **Deadline for Submission of Bids along with time :-** As Per NIT
- (j). **Venue, Time, and Date of Bid Opening:-** Near GBHS II (Shikarpur As Per NIT).
- (k). **Time for Completion from written order of commence: -** 06 Months
- (L). **Liquidity damages:-** -NIL- (0.05 of Estimated Cost or Bid cost per day of delay, but total not exceeding 10%).
- (m). **Deposit Receipt No:** _____ **Date:** _____ **Amount:Rs:** _____
Bank _____
- (n) **D.R.NO:** _____ **DATED:** _____ **Amount 500/-**-(Rupees: Five Hundred only).
- (o) **Tender issued to Mr. / M/s** _____ **Govt: Contractor.**

EXECUTIVE ENGINEER
EDUCATION WORKS DIVISION
SHIKARPUR

BILL OF QUANTITIES

Discription and Rate of Items based on Composite Schedule of Rates

NAME OF WORK :- REHABILITATION OF EXISTING BUILDING FOR BOYS / GIRLS SECONDARY / HIGHER SECONDARY SCHOOLS OF DISTRICT SHIKARPUR (2010-11 PROG:) AT GBHS LAKHI TALUKA LAKHI. ADP # 2320 (ELECTRIFICATION)

Item No.	Quantities	Description of item to be executed at site	Rate	Units	Amount
PART "A" SCHEDULE ITEMS					
1	80	Wiring for light or fan point with 3/029 PVCinsulated wire in 20mm (3/4") channel patti on surface as required (S.No. 129 P-15).	910	per point	72800
2	16	Wiring for plug point with 3/029 PVC insulated wire in 20mm (3/4") channel patti on surface as required (S.I.No:130 P- No:15)	742	per point	11872
3	130	Providing & laying (MAIN or SUB MAIN) PVC insulated with size 2-7/029 copper conductor in 3/4" dia PVC conduit on surface (S.I.No:3 P- No:1)	171	P.Mtr	22230
4	20	Providing & laying (MAIN or SUB MAIN) PVC insulated with size 2-7/036 (4mm ²) copper conductor in 3/4" dia PVC conduit on surface (S.I.No:4 P- No:1).	200	P.Mtr	4000
5	80	Providing & fixing one way SP 5amp switch flush type	54	P.No	4320
6	16	Providing & fixing two pin 5amp plug & socket (S.I.No:225 P- No:33)	83	P.No	1328
7	2	Providing & fixing 3pin 10/15amp plug & socket flush type	151	P.No	302
9	13	Providing & fixing circuit breaker 6,10,15,20, 30,40,50 & 63amp SP (TB-5S) on prepared board as required (S.I.No:202 P- No:30)	916	P.No	11908
10	2	Providing & fixing circuit breaker 6,10,15,20, 30,40,50 & 63amp DP (TB-5S) on prepared board as required. (S.I.No:202 P- No:30)	2456	P.No	4912
11	39	Providing & fixing Bakelite ceiling rose with two terminals	72	P.No	2808
12	31	Providing & fixing Brass Battern holder c(S.I.No:232 P- No:33)	70	P.No	2170
13	15	Providing & fixing Brass Ceiling fan 56" (good quality) (S.I.No:235 P- No:34)	3185	P.No	47775
14	30	Providing & laying (MAIN or SUB MAIN) PVC insulated with size 2-7/052 (10mm ²) copper conductor in 1" dia PVC conduit on surface (S.I.No:6 P- No:1).	428	per Meter	12840
TOTAL :-					199265

PART "B" SCHEDULE ITEMS

1	3	F/F distribution metal board double shutter to accommodate circuit breakers including painting with enamel paint and for other simmlar job on surface (S.I.No:5 P- No:13)	907.96	Each	2724
2	20	F/F mild steel bar fan clamp 15.8 mm (5/8")dia suitable for RCC roof (S.I.No:1 (c) P- No:14)	141.01	Each	2820
3	6	F/F 1-40 walts tube light complete with 40 wats4.0" long rod chok , starter and putty with Phillips components including necessary electric connection and fixing on wall or ceilling etc complete. (S.I.No:1 P- No:33)	396.00	Each	2376
4	10	F/F wall bracket light fancy type superior quality l/n necessary electric connection and fixing on wall or ceilling etc complete (S.I.No:5 P- No:33)	497.00	Each	4970
5	15	F/F Energy sever superior quality l/c fixing on existing holder etc complete (S.I.No:6 P- No:33)	497.00	Each	7455
6	16	F/F bulbs 100 walts (S.I.No:7 P- No:33)	25.00	Each	400
7	33	F/F A.C ceiling fan regulator on metal board recessed in the walls column and covered with plastic sheet (S.I.No:2b P- No:14)	124.30	Each	4102
8	1	F/F earthing set with 2x2x1/4" cooper plate burried in groud at a depth of 12" or less if water comes out from the ground level with salt and charcoal ,etc,in/c.making the pit 12"deep by excavation of all type of soil. Each plat p be connected with No:8	3610.04	Each	3610
TOTAL :-					28457

DRAUGHTSMAN
EDUCATION WORKS DIVISION
SHIKARPUR.
TOTAL (CSR.)

EXECUTIVE ENGINEER
EDUCATION WORKS DIVISION
SHIKARPUR.

Part 'A' %Above / Below _____ Total Amount _____
 Part 'B' %Above / Below _____ Total Amount _____
 Total "A+B" _____

CONTRACTOR

BIDDING DATA

(This section should be filled in by the Engineer/Procuring Agency before issuance of the Bidding Documents).

- (a). **Name of Procuring Agency:-** Executive Engineer (Education Works)
Division Shikarpur.
- PROVINCIAL ADP SCHEMES (Electrical Works)**
- (b). **Brief Description of Works:-** ADP 277 UP-GRADATION OF MIDDLE SCHOOLS TO
HIGH SCHOOLS IN SINDH (2008-09 PROGRAMME).
- GBMS MUHAMMAD SALEH PAHORE
- (c). **Procuring Agency's address:-** Executive Engineer (Education Works) Division Shikarpur
Near GBHS No.II Shikarpur.
- (d). **Estimated Cost:-** 0.200 (Millions).
- (e). **Amount of Bid Security:-** 2% (Fill in lump sum amount or in % age of bid amount /estimated cost, but not exceeding 5%)
- (f). **Period of Bid Validity (days):-** 60 Days (Not more than sixty days).
- (g). **Security Deposit:-(including bid security):-** 10%
(in % age of bid amount /estimated cost equal to 10%)
- (h). **Percentage, if any, to be deducted from bills:-** 7.50% Income tax
- (i). **Deadline for Submission of Bids along with time :-** As Per NIT
- (j). **Venue, Time, and Date of Bid Opening:-** Near GBHS II (Shikarpur As Per NIT).
- (k). **Time for Completion from written order of commence: -** 06 Months
- (L). **Liquidity damages:-** -NIL- (0.05 of Estimated Cost or Bid cost per day of delay, but total not exceeding 10%).
- (m). **Deposit Receipt No:** _____ **Date:** _____ **Amount:Rs:** _____
Bank _____
- (n) **D.R.NO:** _____ **DATED:** _____ **Amount 500/-**(Rupees: Five Hundred only).
- (o) **Tender issued to Mr. / M/s** _____ **Govt: Contractor.**

EXECUTIVE ENGINEER
EDUCATION WORKS DIVISION
SHIKARPUR

BILL OF QUANTITIES

Description and Rate of Items based on Composite Schedule of Rates

NAME OF WORK :- UP-GRADATION OF MIDDLE SCHOOL TO HIGH SCHOOL IN SINDH 2008-09 PROGRAMME @ 3BMS MUHAMMAD SALEH PAHORE TALUKA KHANPUR. (INTERNAL ELECTRIFICATION)

Item No.	Quantities	Description of item to be executed at site	Rate	Units	Amount
PART "A" SCHEDULE ITEMS					
1	88	Wiring for light or fan point with 3/029 PVC insulated wire in 20mm (3/4") channel patti on surface as required (S.No. 129 P-15).	910	per point	80080
2	16	Wiring for plug point with 3/029 PVC insulated wire in 20mm (3/4") channel patti on surface as required (S.I.No:130 P- No:15)	742	per point	11872
3	3	Wiring for call bell point with 3/029 PVC insulated wire in 20mm (3/4") channel patti on surface as required. (S.I.No:131 P- No:15)	1590	per point	4770
4	100	Providing & laying (MAIN or SUB MAIN) PVC insulated with size 2-7/029 copper conductor in 3/4" dia PVC conduit on surface (S.I.No:3 P- No:1)	171	P.Mtr	17100
5	30	Providing & laying (MAIN or SUB MAIN) PVC insulated with size 2-7/036 (4mm ²) copper conductor in 3/4" dia PVC conduit on surface.	200	per Meter	6000
9	75	Providing & laying (MAIN or SUB MAIN) PVC insulated with size 2-7/044 (6mm ²) copper conductor in 1" dia PVC conduit on surface (S.I.No:5 P- No:1).	305	P.Mtr	22875
7	88	Providing & fixing one way SP 5amp switch flush type(S.I.No:219 P- No:33)	54	P.No	4752
8	16	Providing & fixing two pin 5amp plug & socket (S.I.No:225 P- No:33)	83	P.No	1328
9	4	Providing & fixing three pin 10/15amp plug & socket flush type (S.I.No:226 P- No:33)	151	P.No	604
10	20	Providing & fixing circuit breaker 6,10,15,20, 30,40,50 & 63amp SP (TB-5S) on prepared board as required (S.I.No:202 P- No:30)	916	P.No	18320
8	2	Providing & fixing circuit breaker 3,5,10,15,20 & 30amp TP (XS-30NS[NB]) on prepared board as required. (S.I.No:205 P- No:31)	5301	Each	10602
12	1	Providing & fixing circuit breaker 15,20,30, 40,50,60,75 & 100amp TP (XS-100NS) on prepared board as required (S.I.No:207 P- No:31)	9261	P.No	9261
12	37	Providing & fixing Bakelite ceiling rose with two terminals (S.I.No:228 P- No:33)	72	P.No	2664
13	39	Providing & fixing Brass Battern holder (S.I.No:232 P- No:33)	70	P.No	2730
14	30	Providing & laying (MAIN or SUB MAIN) PVC insulated with size 2-7/052 (10mm ²) copper conductor in 1" dia PVC conduit on surface (S.I.No:6 P- No:1).	428	P.Mtr	12840
TOTAL :-					205798

PART "B" SCHEDULE ITEMS

1	4	P/F distribution metal board double shutter to accommodate circuit breakers including painting with enamel paint and for other similar job on surface (S.I.No:18 P- No:13)	907.96	P.Sft	3632
2	26	P/F mild steel bar fan clamp 15.8 mm (5/8") dia suitable for RCC roof (S.I.No:1 (c) P- No:14)	141.01	Each	3666
3	12	P/F wall bracket light fancy type superior quality including necessary electric connection and fixing on wall or ceiling etc complete.(S.I.No:5 P- No:33)	497.00	Each	5964
4	6	P/F energy sever superior quality including fixing on existing holder etc complete.(S.I.No:6 P- No:33)	497.00	Each	2982
5	14	P/F bulb 25 Watts	25.00	Each	350
6	2	P/F earthing set with 2x2x1/4" cooper plate buried in groud at a depth of 12" or less if water comes out from the ground level with salt and chorcoal ,etc. n/c.making the pit 12"deep by excavation of all type of soil. Earth plat to be connected with No:8	3610.04	Each	7220
7	26	P/F A.C ceiling fan regulator on metal board recessed in the walls column and covered with plastic sheet (S.I.No:2b P- No:14)	124.30	Each	3232
3	3	P/F AC or DC electric bell 200/250 volt 70MM. (S.I.No:21 P- No:11)	150.70	Each	452
3	3	P/F flush type electric bell bush button (S.I.No:23 P- No:12)	25.18	Each	76
10	11	P/F 1-40 wats tube light complete with 40 wats 4.0" long rod chok , starter and putty with Phillips components including necessary electric connection and fixing on wall or ceiling etc complete. (S.I.No:1 P- No:33)	396.00	Each	4356
TOTAL :-					31930

Amount Total (CSR)
DRAUGHTSMAN
EDUCATION WORKS DIVISION
SHIKARPUR.

EXECUTIVE ENGINEER
EDUCATION WORKS DIVISION
SHIKARPUR.

Part "A"

%Above / Below _____ Total Amount _____

Part "B"

%Above / Below _____ Total Amount _____

Total "A+B" _____

CONTRACTOR

BIDDING DATA

(This section should be filled in by the Engineer/Procuring Agency before issuance of the Bidding Documents).

(a). **Name of Procuring Agency:-** Executive Engineer (Education Works)
Division Shikarpur.

PROVINCIAL ADP SCHEMES (Electrical Works)

(b). **Brief Description of Works:-** ADP 277 UP-GRADATION OF MIDDLE SCHOOLS TO
HIGH SCHOOLS IN SINDH (2008-09 PROGRAMME).

GBMS MAROON KAKEPOTO

(c). **Procuring Agency's address:-** Executive Engineer (Education Works) Division Shikarpur
Near GBHS No.II Shikarpur.

(d). **Estimated Cost:-** 0.200 (Millions).

(e). **Amount of Bid Security:-** 2% (Fill in lump sum amount or in % age of bid amount /estimated cost, but not exceeding 5%)

(f). **Period of Bid Validity (days):-** 60 Days (Not more than sixty days).

(g). **Security Deposit:-(including bid security):-** 10%
(in % age of bid amount /estimated cost equal to 10%)

(h). **Percentage, if any, to be deducted from bills:-** 7.50% Income tax

(i). **Deadline for Submission of Bids along with time :-** As Per NIT

(j). **Venue, Time, and Date of Bid Opening:-** Near GBHS II (Shikarpur As Per NIT).

(k). **Time for Completion from written order of commence: -** 06 Months

(L). **Liquidity damages:-** -NIL- (0.05 of Estimated Cost or Bid cost per day of delay, but total not exceeding 10%).

(m). **Deposit Receipt No:** _____ **Date:** _____ **Amount:Rs:** _____

Bank _____

(n) **D.R.NO:** _____ **DATED:** _____ **Amount 500/- (Rupees: Five Hundred only).**

(o) **Tender issued to Mr. / M/s** _____ **Govt: Contractor.**

EXECUTIVE ENGINEER
EDUCATION WORKS DIVISION
SHIKARPUR

BILL OF QUANTITIES

Discription and Rate of Items based on Composite Schedule of Rates

NAME OF WCRK :- UP-GRADATION OF MIDDLE SCHOOL TO HIGH SCHOOL IN SINDH 2008-09 PROGRAMME @ GBMS MAROON KAKEPOTA TALUKA GHARI YASIN. (INTERNAL ELECTRIFICATION)

Item No.	Quantities	Description of item to be executed at site	Rate	Units	Amount
PART "A" SCHEDULE ITEMS					
1	88	Wiring for light or fan point with 3/029 PVCinsulated wire in 20mm (3/4") channel patti on surface as required (S.No. 129 P-15).	910	per point	80080
2	16	Wiring for plug point with 3/029 PVC insulated wire in 20mm (3/4") channel patti on surface as required (S.I.No:130 P- No:15)	742	per point	11872
3	3	Wiring for call bell point with 3/029 PVC insulated wire in 20mm (3/4") channel patti on surface as required. (S.I.No:131 P- No:15)	1590	per point	4770
4	100	Providing & laying (MAIN or SUB MAIN) PVC insulated with size 2-7/029 copper conductor in 3/4" dia PVC conduit on surface (S.I.No:3 P- No.1)	171	P.Mtr	17100
5	30	Providing & laying (MAIN or SUB MAIN) PVC insulated with size 2-7/036 (4mm ²) copper conductor in 3/4" dia PVC conduit on surface.	200	per Meter	6000
9	75	Providing & laying (MAIN or SUB MAIN) PVC insulated with size 2-7/044 (6mm ²) copper conductor in 1" dia PVC conduit on surface (S.I.No:5 P- No:1).	305	P.Mtr	22875
7	88	Providing & fixing one way SP 5amp switch flush type(S.I.No:219 P- No:33)	54	P.No	4752
8	16	Providing & fixing two pin 5amp plug & socket (S.I.No:225 P- No:33)	83	P.No	1328
9	4	Providing & fixing three pin 10/15amp plug & socket flush type (S.I.No:226 P- No:33)	151	P.No	604
10	20	Providing & fixing circuit breaker 6,10,15,20, 30,40,50 & 63amp SP (TB-5S) on prepared board as required (S.I.No:202 P- No:30)	916	P.No	18320
8	2	Providing & fixing circuit breaker 3,5,10,15,20 & 30amp TP (XS-30NS[NB]) on prepared board as required. (S.I.No:205 P- No:31)	5301	Each	10602
12	1	Providing & fixing circuit breaker 15,20,30, 40,50,60,75 & 100amp TP (XS-00NS) on prepared board as required (S.I.No:207 P- No:31)	9261	P.No	9261
12	37	Providing & fixing Bakelite ceiling rose with two terminals (S.I.No:228 P- No:33)	72	P.No	2664
13	39	Providing & fixing Brass Battern holder c(S.I.No:232 P- No:33)	70	P.No	2730
14	30	Providing & laying (MAIN or SUB MAIN) PVC insulated with size 2-7/052 (10mm ²) copper conductor in 1" dia PVC conduit on surface (S.I.No:6 P- No:1).	428	P.Mtr	12840
TOTAL :-					205798

PART "B" SCHEDULE ITEMS					
1	4	P/F distribution metal board double shutter to accommodate circuit breakers including painting with enamel paint and for other simmlar job on surface (S.I.No:18 P- No:13)	907.96	P.Sft	3632
2	26	P/F mild steel bar fan clamp 15.8 mm (5/8")dia suitable for RCC roof (S.I.No:14 P- No:14)	141.01	Each	3666
3	12	P/F wall bracket light fancy type superior quality including necessary electric connection and fixing on wall or ceiling etc complete.(S.I.No:5 P- No:33)	497.00	Each	5964
4	6	P/Fenergy sever, superior quality including fixing on existing holder etc complete.(S.I.No:6 P- No:33)	497.00	Each	2982
5	14	P/F Bulb 25 Watts	25.00	Each	350
6	2	P/F earthing set with 2x2x1/4" cooper plate burried in groud at a depth of 12" or less if water comes out from the ground level with salt and chorcoal etc.in/c.making the pit 12"deep by excavation of all type of soil. Earth plat to be connected with No:8	3610.04	Each	7220
7	26	P/F A.C ceiling fan regulator on metal board recessed in the walls column and covered with plastic sheet (S.I.No:2b P- No:14)	124.30	Each	3232
8	3	P/F AC or DC electric bell 200/250 volt 70MM. (S.I.No:21 P- No:11)	150.70	Each	452
9	3	P/F flush type electric bell bush button (S.I.No:23 P- No:12)	25.19	Each	76
10	11	P/F 1-40 watts tube light complete with 40 wats4.0" long rod chok , starter and patty with Phillips components including necessary electric connection and fixing on wall or ceiling etc complete. (S.I.No:1 P- No:33)	406.00	Each	4356
TOTAL :-					31930

**EDUCATION WORKS DIVISION
SHIKARPUR.**

**EXECUTIVE ENGINEER
EDUCATION WORKS DIVISION
SHIKARPUR.**

TOTAL (CSR:)

Part "A" %Above / Below _____ Total Amount _____
Part "B" %Above / Below _____ Total Amount _____

Total "A+B" _____

CONTRACTOR

BIDDING DATA

(This section should be filled in by the Engineer/Procuring Agency before issuance of the Bidding Documents).

- (a). **Name of Procuring Agency:-** Executive Engineer (Education Works)
Division Shikarpur.
- PROVINCIAL ADP SCHEMES (Electrical Works)**
- (b). **Brief Description of Works:-** ADP 279 REHABILITATION OF EXISTING HIGH/HIGHER
SECONDARY SCHOOLS IN SINDH (2008-09 PROGRAMME)
- i. GGHS DAKHAN
- (c). **Procuring Agency's address:-** Executive Engineer (Education Works) Division Shikarpur
Near GBHS No.II Shikarpur.
- (d). **Estimated Cost:-** 0.200 (Millions).
- (e). **Amount of Bid Security:-** 2% (Fill in lump sum amount or in % age of bid amount /estimated cost, but not exceeding 5%)
- (f). **Period of Bid Validity (days):-** 60 Days (Not more than sixty days).
- (g). **Security Deposit:-(including bid security):-** 10%
(in % age of bid amount /estimated cost equal to 10%)
- (h). **Percentage, if any, to be deducted from bills:-** 7.50% Income tax
- (i). **Deadline for Submission of Bids along with time :-** As Per NIT
- (j). **Venue, Time, and Date of Bid Opening:-** Near GBHS II (Shikarpur As Per NIT).
- (k). **Time for Completion from written order of commence: -** 06 Months
- (L). **Liquidity damages:-** -NIL- (0.05 of Estimated Cost or Bid cost per day of delay, but total not exceeding 10%).
- (m). **Deposit Receipt No:** _____ **Date:** _____ **Amount:Rs:** _____
Bank _____
- (n) **D.R.NO:** _____ **DATED:** _____ **Amount 500/-**-(Rupees: Five Hundred only).
- (o) Tender issued to Mr. / M/s _____ Govt. Contractor.

EXECUTIVE ENGINEER
EDUCATION WORKS DIVISION
SHIKARPUR

BILL OF QUANTITIES

Discription and Rate of Items based on Composite Schedule of Rates

NAME OF WORK :- REHABILITATION OF EXISTING HIGH / HIGHER SECONDARY SCHOOLS IN SINDH 2008-09 PROGRAMME @ GGHS DAKHAN TALUKA GHARI YASIN. (INTERNAL ELECTRIFICATION)

Item No.	Quantities	Description of item to be executed at site	Rate	Units	Amount
PART "A" SCHEDULE ITEMS					
1	20	Wiring for light or fan point with 3/029 PVCinsulated wire in 20mm (3/4") channel patti on surface as required (S.No. 129 P-15).	910	per point	18200
2	4	Wiring for plug point with 3/029 PVC insulated wire in 20mm (3/4") channel patti on surface as required (S.I.No:130 P- No:15)	742	per point	2968
3	2	Wiring for call bell point with 3/029 PVC insulated wire in 20mm (3/4") channel patti on surface as required. (S.I.No:131 P- No:15)	1590	per point	3180
4	70	Providing & laying (MAIN or SUB MAIN) PVC insulated with size 2-7/029 copper conductor in 3/4" dia PVC conduit on surface (S.I.No:3 P- No:1)	171	P.Mtr	11970
5	30	Providing & laying (MAIN or SUB MAIN) PVC insulated with size 2-7/036 (4mm ²) copper conductor in 3/4" dia PVC conduit on surface. (S.I.No:11 P- No:2)	200	per Meter	6000
9	20	Providing & laying (MAIN or SUB MAIN) PVC insulated with size 2-7/044 (6mm ²) copper conductor in 1" dia PVC conduit on surface (S.I.No:5 P- No:1).	305	P.Mtr	6100
7	20	Providing & fixing one way SP 5amp switch flush type(S.I.No:219 P- No:33)	54	P.No	1080
8	4	Providing & fixing two pin 5amp plug & socket (S.I.No:225 P- No:33)	83	P.No	332
9	2	Providing & fixing, three pin 10/15amp plug & socket flush type (S.I.No:226 P- No:33)	151	P.No	302
10	6	Providing & fixing circuit breaker 6,10,15,20, 30,40,50 & 63amp SP (TB-5S) on prepared board as required (S.I.No:202 P- No:30)	916	P.No	5496
11	1	Providing & fixing circuit breaker 6,10,15,20, 30,40,50 & 63amp DP (TB-5S) on prepared board as required. (S.I.No:202 P- No:30)	2456	P.No	2456
12	6	Providing & fixing Bakelite ceiling rose with two terminals (S.I.No:228 P- No:33)	72	P.No	432
13	14	Providing & fixing Brass Battern holder c(S.I.No:232 P- No:33)	70	P.No	980
14	4	Providing & fixing Brass Ceiling fan 56" (good quality) (S.I.No:235 P- No:34)	3185	P.No	12740
6	1	Construction of RCC foundation as per following specification & instruction of EI for 31ft/40ft long tubular pole Excavation of soft/hard soil 3'x3'x5.5' Stone soiling 3'x3'x6" making lean in the ratio of 1:4:8 Length of MS bolts 6 1/2" (3/4" dia) 4 no's & making thread on MS rod Template 16"x16"x 1/4" Rings 1/4" dia round bar 4 no's to the welded with MS rod RCC foundation ratio 1:2:4 with appropriate size 2'x2'x6.5' (S.I.No:132 P- No:16)	15168	P.No	15168
7	1	Providing & fixing of MS tabular pole as following specification to be fixed on pre-cast foundation with the help of hydraulic crane & manual labour 20ft-(6" dia) x 5.5ft (5" dia) x 5.5ft (4" dia) = 31ft wall thickness 8 SWG Base plate 18" x 18" x 3/4" Hole 4 no's stiffeners 4 nos. 9 1/2" x 4 1/2" x 1/2" Making window in the pole required size with LN key provision Two coats red oxide (2 coat) as rust preventive & Of required oil paint (2 coat) as per site requirement & instruction of EI (S.I.No:132 P- No:16)	36697	P.No	36697
14	2	Providing & Fixing of flood light 400 watts (HPIT) having IP65 classification with 400w lamp, choke, capacitor, igniter & Internal wiring complete in all respect at the height up to 40ft with the help hydraulic crane and manual labour as per site requirement and instruction of EI (S.I.No:164 P- No:26)	16980	P.No	33960
14	35	Providing & laying (MAIN or SUB MAIN) PVC insulated with size 2-7/052 (10 mm ²) copper conductor in 1" dia PVC conduit on surface (S.I.No:6 P- No:1).	428	P.Mtr	14980
TOTAL :-					173041

PART "B" SCHEDULE ITEMS

1	1.5	P/F distribution metal board double shutter to accommodate circuit breakers including painting with enemel paint and for other simmlar job on surface (S.I.No:18 P- No:13)	907.96	P.Sft	1362
2	4	P/F mild steel bar fan clamp 15.8 mm (5/8")dia suitable for RCC roof (S.I.No:1(c) P- No:14)	141.01	Each	564
4	4	P/F wall bracket light fancy type superior quality including necessary electric connection and fixing on wall oe ceiling etc complete.(S.I.No:5 P- No:33)	497.00	Each	1988
5	12	P/Fenergy sever superior quality including fixing on existing holder etc complete.(S.I.No:6 P- No:33)	497.00	Each	5964
6	2	P/F earthing set with 2x2x1/4" cooper plate burried in groud at a depth of 12" or less if water comes out from the ground level with salt and chorcoal etc,in/c.making the pit 12"deep by excavation of all type of soil. Earth plat to be connected with No:8	3610.04	Each	7220
7	4	F/F A.C ceiling fan regulator on metal board recessed in the walls column and covered with plastic sheet (S.I.No:2b P- No:14)	124.30	Each	497

Item No.	Quantities	Description of item to be executed at site	Rate	Units	Amount
8	11	P/F 1-40 wats tube light complete with 40 wats 4.0" long rod chok , starter and putty with Phillips components including necessary electric connection and fixing on wall or ceiling etc complete. (S.I.No:1 P- No:33)	396.00	Each	4356
9	2	P/F AC or DC electric bell 200/250 volt 70MM. (S.I.No:21 P- No:11)	150.70	Each	301
10	2	P/F flush type electric bell bush button (S.I.No:23 P- No:12)	25.19	Each	50
				TOTAL :-	22303

[Signature]
DRAUGHTSMAN
EDUCATION WORKS DIVISION
SHIKARPUR.
TOTAL (CSR:)

[Signature]
EXECUTIVE ENGINEER
EDUCATION WORKS DIVISION
SHIKARPUR.

Part "A"

%Above / Below _____

Total Amount _____

Part "B"

%Above / Below _____

Total Amount _____

Total "A+B" _____

CONTRACTOR

BIDDING DATA

(This section should be filled in by the Engineer/Procuring Agency before issuance of the Bidding Documents).

(a). **Name of Procuring Agency:-** Executive Engineer (Education Works)
Division Shikarpur.

PROVINCIAL ADP SCHEMES (Electrical Works)

(b). **Brief Description of Works:-** ADP 279 REHABILITATION OF EXISTING HIGH/HIGHER
SECONDARY SCHOOLS IN SINDH (2008-09 PROGRAMME).

ii. GGHS MADEJI

(c). **Procuring Agency's address:-** Executive Engineer (Education Works) Division Shikarpur
Near GBHS No.II Shikarpur.

(d). **Estimated Cost:-** 0.200 (Millions).

(e). **Amount of Bid Security:-** 2% (Fill in lump sum amount or in % age of bid amount /estimated cost, but not exceeding 5%)

(f). **Period of Bid Validity (days):-** 60 Days (Not more than sixty days).

(g). **Security Deposit:-(including bid security):-** 10%
(in % age of bid amount /estimated cost equal to 10%)

(h). **Percentage, if any, to be deducted from bills:-** 7.50% Income tax

(i). **Deadline for Submission of Bids along with time :-** As Per NIT

(j). **Venue, Time, and Date of Bid Opening:-** Near GBHS II (Shikarpur As Per NIT).

(k). **Time for Completion from written order of commence: -** 06 Months

(L). **Liquidity damages:-** -NIL- (0.05 of Estimated Cost or Bid cost per day of delay, but total not exceeding 10%).

(m). **Deposit Receipt No:** _____ **Date:** _____ **Amount:Rs:** _____

Bank _____

(n) **D.R.NO:** _____ **DATED:** _____ **Amount 500/- (Rupees: Five Hundred only)**

(o). **Tender issued to Mr. / M/s** _____ **Govt: Contractor.**

EXECUTIVE ENGINEER
EDUCATION WORKS DIVISION
SHIKARPUR

BILL OF QUANTITIES

Discription and Rate of Items based on Composite Schedule of Rates

NAME OF WORK :- REHABILITATION OF EXISTING HIGH / HIGHER SECONDARY SCHOOLS IN SINDH 2008-09 PROGRAMME @ GGHS MADEJI TALUKA GHARI YASIN. (INTERNAL ELECTRIFICATION)

Item No.	Quantities	Description of item to be executed at site	Rate	Units	Amount
PART "A" SCHEDULE ITEMS					
1	64	Wiring for light or fan point with 3/029 PVC insulated wire in 20mm (3/4") channel patti on surface as required (S.No. 129 P-15).	910	per point	58240
2	14	Wiring for plug point with 3/029 PVC insulated wire in 20mm (3/4") channel patti on surface as required (S.I.No:130 P- No:15)	742	per point	10388
3	1	Wiring for call bell point with 3/029 PVC insulated wire in 20mm (3/4") channel patti on surface as required. (S.I.No:131 P- No:15)	1590	per point	1590
4	100	Providing & laying (MAIN or SUB MAIN) PVC insulated with size 2-7/029 copper conductor in 3/4" dia PVC conduit on surface (S.I.No:3 P- No:1)	171	P.Mtr	17100
5	30	Providing & laying (MAIN or SUB MAIN) PVC insulated with size 2-7/036 (4mm2) copper conductor in 3/4" dia PVC conduit on surface.	200	per Meter	6000
9	10	Providing & laying (MAIN or SUB MAIN) PVC insulated with size 2-7/044 (6mm2) copper conductor in 1" dia PVC conduit on surface (S.I.No:5 P- No:1).	305	P.Mtr	3050
7	64	Providing & fixing one way SP 5amp switch flush type(S.I.No:210 P- No:33)	54	P.No	3456
8	20	Providing & fixing two pin 5amp plug & socket (S.I.No:225 P- No:33)	83	P.No	1660
9	1	Providing & fixing three pin 10/15amp plug & socket flush type (S.I.No:226 P- No:33)	151	P.No	151
10	14	Providing & fixing circuit breaker 6,10,15,20, 30,40,50 & 63amp SP (TB-5S) on prepared board as required (S.I.No:202 P- No:30)	916	P.No	12824
11	1	Providing & fixing circuit breaker 6,10,15,20, 30,40,50 & 63amp DP (TB-5S) on prepared board as required. (S.I.No:202 P- No:30)	2456	Each	2456
12	40	Providing & fixing Bakelite ceiling rose with two terminals (S.I.No:228 P- No:33)	72	P.No	2880
13	20	Providing & fixing Brass Battern holder c(S.I.No:232 P- No:33)	70	P.No	1400
14	15	Providing & fixing Brass Ceiling fan 56" (good quality) (S.I.No:235 P- No:34)	3185	P.No	47775
14	30	Providing & laying (MAIN or SUB MAIN) PVC insulated with size 2-7/052 (10 mm2) copper conductor in 1" dia PVC conduit on surface (S.I.No:6 P- No:1).	428	P.Mtr	12840
TOTAL :-					181810

PART "B" SCHEDULE ITEMS					
1	1.5	P/F distribution metal board double shutter to accommodate circuit breakers including painting with enamel paint and for other simmlar job on surface (S.I.No:18 P- No:13)	907.96	P.Sft	1362
2	24	P/F mild steel bar fan clamp 15.8 mm (5/8")dia suitable for RCC roof (S.I.No:1 (c) P- No:14)	141.01	Each	3384
3	12	P/F wall bracket light fancy type superior quality including necessary electric connection and fixing on wall or ceiling etc complete.(S.I.No:5 P- No:33)	497.00	Each	5964
4	20	P/Fenergy sever superior quality including fixing on existing holder etc complete.(S.I.No:6 P- No:33)	497.00	Each	9940
5	1	P/F earthing set with 2x2x1/4" cooper plate burried in groud at a depth of 12" or less if water comes out from the ground level with salt and chorcoal etc,in/c.making the pit 12"deep by excavation of all type of soil. Earth plat to be connected with No:8	3610.04	Each	3610
6	24	P/F A.C ceiling fan regulator on metal board recessed in the walls column and covered with plastic sheet (S.I.No:2b P- No:14)	124.30	Each	2983
7	1	P/F AC or DC electric bell 200/250 volt 70MM. (S.I.No:21 P- No:11)	150.70	Each	151
8	1	P/F flush type electric bell bush button (S.I.No:23 P- No:12)	25.19	Each	25
9	8	P/F 1-40 walts tube light complete with 40 wats4.0" long rod chok , starter and putty with /Phillips components including necessary electric connection and fixing on wall or ceiling etc complete. (S.I.No:1 P- No:33)	396.00	Each	3168
TOTAL :-					30587

Amount Total (CSR)

DRAWN BY
EDUCATION WORKS DIVISION
SHIKARPUR.

EXECUTIVE ENGINEER
EDUCATION WORKS DIVISION
SHIKARPUR.

Part "A" %Above / Below _____ Total Amount _____

Part "B" %Above / Below _____ Total Amount _____

Total "A+B" _____

CONTRACTOR

BIDDING DATA

(This section should be filled in by the Engineer/Procuring Agency before issuance of the Bidding Documents).

- (a). **Name of Procuring Agency:-** Executive Engineer (Education Works)
Division Shikarpur.
- PROVINCIAL ADP SCHEMES (Electrical Works)**
- (b). **Brief Description of Works:-** ADP 279 REHABILITATION OF EXISTING HIGH/HIGHER
SECONDARY SCHOOLS IN SINDH (2008-09 PROGRAMME).
- iii. GBHS RUSTAM
- (c). **Procuring Agency's address:-** Executive Engineer (Education Works) Division Shikarpur
Near GBHS No.II Shikarpur.
- (d). **Estimated Cost:-** 0.200 (Millions).
- (e). **Amount of Bid Security:-** 2% (Fill in lump sum amount or in % age of bid amount /estimated cost, but not exceeding 5%)
- (f). **Period of Bid Validity (days):-** 60 Days (Not more than sixty days).
- (g). **Security Deposit:-(including bid security):-** 10%
(in % age of bid amount /estimated cost equal to 10%)
- (h). **Percentage, if any, to be deducted from bills:-** 7.50% Income tax
- (i). **Deadline for Submission of Bids along with time :-** As Per NIT
- (j). **Venue, Time, and Date of Bid Opening:-** Near GBHS II (Shikarpur As Per NIT).
- (k). **Time for Completion from written order of commence: -** 06 Months
- (L). **Liquidity damages:-** -NIL- (0.05 of Estimated Cost or Bid cost per day of delay, but total not exceeding 10%).
- (m). **Deposit Receipt No:** _____ **Date:** _____ **Amount:Rs:** _____
- Bank** _____
- (n) **D.R.NO:** _____ **DATED:** _____ **Amount 500/- (Rupees: Five Hundred only).**
- (o). **Tender issued to Mr. / M/s** _____ **Govt: Contractor.**

EXECUTIVE ENGINEER
EDUCATION WORKS DIVISION
SHIKARPUR

BILL OF QUANTITIES

Discription and Rate of Items based on Composite Schedule of Rates

NAME OF WORK :- REHABILITATION OF EXISTING HIGH / HIGHER SECONDARY SCHOOLS IN SINDH 2008-09 PROGRAMME @ GBHS RUSTAM TALUKA LAKHI. (INTERNAL ELECTRIFICATION)

Item No.	Quantities	Description of item to be executed at site	Rate	Units	Amount
PART "A" SCHEDULE ITEMS					
1	58	Wiring for light or fan point with 3/029 PVCinsulated wire in 20mm (3/4") channel patti on surface as required (S.No. 129 P-15).	910	per point	52780
2	10	Wiring for plug point with 3/029 PVC insulated wire in 20mm (3/4") channel patti on surface as required (S.I.No:130 P- No:15)	742	per point	7420
3	1	Wiring for call bell point with 3/029 PVC insulated wire in 20mm (3/4") channel patti on surface as required. (S.I.No:131 P- No:15)	1590	per point	1590
4	90	Providing & laying (MAIN or SUB MAIN) PVC insulated with size 2-7/029 copper conductor in 3/4" dia PVC conduit on surface (S.I.No:3 P- No:1)	171	P.Mtr	15390
5	20	Providing & laying (MAIN or SUB MAIN) PVC insulated with size 2-7/036 (4mm2) copper conductor in 3/4" dia PVC conduit on surface.	200	per Meter	4000
9	10	Providing & laying (MAIN or SUB MAIN) PVC insulated with size 2-7/044 (6mm2) copper conductor in 1" dia PVC conduit on surface (S.I.No:5 P- No:1).	305	P.Mtr	3050
7	58	Providing & fixing one way SP 5amp switch flush type(S.I.No:219 P- No:33)	54	P.No	3132
8	10	Providing & fixing two pin 5amp plug & socket (S.I.No:225 P- No:33)	83	P.No	830
9	1	Providing & fixing three pin 10/15amp plug & socket flush type (S.I.No:226 P- No:33)	151	P.No	151
10	10	Providing & fixing circuit breaker 6,10,15,20, 30,40,50 & 63amp SP (TB-5S) on prepared board as required (S.I.No:202 P- No:30)	916	P.No	9160
11	1	Providing & fixing circuit breaker 6,10,15,20, 30,40,50 & 63amp DP (TB-5S) on prepared board as required. (S.I.No:202 P- No:30)	2456	Each	2456
12	30	Providing & fixing Bakelite ceiling rose with two terminals (S.I.No:228 P- No:33)	72	P.No	2160
13	22	Providing & fixing Brass Battern holder c(S.I.No:232 P- No:33)	70	P.No	1540
14	24	Providing & fixing Brass Ceiling fan 56" (good quality) (S.I.No:235 P- No:34)	3185	P.No	76440
14	30	Providing & laying (MAIN or SUB MAIN) PVC insulated with size 2-7/052 (10 mm2) copper conductor in 1" dia PVC conduit on surface (S.I.No:6 P- No:1).	428	P.Mtr	12840
TOTAL :-					192939

PART "B" SCHEDULE ITEMS					
1	3	P/F distribution metal board double shutter to accommodate circuit breakers including painting with enamel paint and for other simmlar job on surface (S.I.No:18 P- No:13)	907.96	P.Sft	2724
2	24	P/F mild steel bar fan clamp 15.8 mm (5/8")dia suitable for RCC roof (S.I.No:1 (c) P- No:14)	141.01	Each	3384
3	6	P/F wall bracket light fancy type superior quality including necessary electric connection and fixing on wall oe ceiling etc complete.(S.I.No:5 P- No:33)	497.00	Each	2982
4	22	I/Fenergy sever superior quality including fixing on existing holder etc complete.(S.I.No:6 P- No:33)	497.00	Each	10934
5	1	P/F earthing set with 2x2x1/4" cooper plate burried in groud at a depth of 12" or less if water comes out from the ground level with salt and chorcoal etc,In/c.making the pit 12"deep by excavation of all type of soil. Earth plat to be connected with No:8	3610.04	Each	3610
6	24	F/F A.C ceiling fan regulator on metal board recessed in the walls column and covered with plastic sheet (S.I.No:2b P- No:14)	124.30	Each	2983
7	1	F/F AC or DC electric bell 200/250 volt 70MM. (S.I.No:21 P- No:11)	150.70	Each	151
8	1	P/F flush type electric bell bush button (S.I.No:23 P- No:12)	25.19	Each	25
9	6	F/F 1-40 wats tube light complete with 40 wats4.0" long rod chok , starter and putty with Philips components including necessary electric connection and fixing on wall or ceiling etc complete. (S.I.No:1 P- No:33)	396.00	Each	2376
EXECUTIVE TOTAL					29169

Amount Total (CSR) **EDUCATION WORKS DIVISION SHIKARPUR.**

EXECUTIVE ENGINEER
EDUCATION WORKS DIVISION SHIKARPUR.

Part "A" %Above / Below _____ Total Amount _____
 Part "B" %Above / Below _____ Total Amount _____
 Total "A+B" _____

CONTRACTOR _____

BIDDING DATA

(This section should be filled in by the Engineer/Procuring Agency before issuance of the Bidding Documents).

(a). **Name of Procuring Agency:-** Executive Engineer (Education Works)
Division Shikarpur.

PROVINCIAL ADP SCHEMES (Electrical Works)

(b). **Brief Description of Works:-** ADP 282 UP-GRADATION OF MIDDLE SCHOOLS TO HIGH SCHOOLS & HIGH SCHOOL TO HIGHER SECONDARY SCHOOLS IN SINDH (2007-08 PROGRAMME).

GGMS JINDO DERO

(c). **Procuring Agency's address:-** Executive Engineer (Education Works) Division Shikarpur
Near GBHS No.II Shikarpur.

(d). **Estimated Cost:-** 0.200 (Millions).

(e). **Amount of Bid Security:-** 2% (Fill in lump sum amount or in % age of bid amount /estimated cost, but not exceeding 5%)

(f). **Period of Bid Validity (days):-** 60 Days (Not more than sixty days).

(g). **Security Deposit:-(including bid security):-** 10%
(in % age of bid amount /estimated cost equal to 10%)

(h). **Percentage, if any, to be deducted from bills:-** 7.50% Income tax

(i). **Deadline for Submission of Bids along with time :-** As Per NIT

(j). **Venue, Time, and Date of Bid Opening:-** Near GBHS II (Shikarpur As Per NIT).

(k). **Time for Completion from written order of commence: -** 06 Months

(L). **Liquidity damages:-** -NIL- (0.05 of Estimated Cost or Bid cost per day of delay, but total not exceeding 10%).

(m). **Deposit Receipt No:** _____ **Date:** _____ **Amount:Rs:** _____

Bank _____

(n) **D.R.NO:** _____ **DATED:** _____ **Amount 500/-**(Rupees: Five Hundred only).

(o) **Tender issued to Mr. / M/s** _____ **Govt. Contractor.**

EXECUTIVE ENGINEER
EDUCATION WORKS DIVISION
SHIKARPUR

BILL OF QUANTITIES

Discription and Rate of Items based on Composite Schedule of Rates

NAME OF WORK :- UP-GRADATION OF MIDDLE SCHOOL TO HIGH SCHOOL IN SINDH 2007-08
PROGRAMME: @ GGMS JINDO DERO TALUKA GHARI YASIN. (INTERNAL ELECTRIFICATION)

Item No.	Quantities	Description of item to be executed at site	Rate	Units	Amount
<u>PART "A" SCHEDULE ITEMS</u>					
1	72	Wiring for light or fan point with 3/029 PVCinsulated wire in 20mm (3/4") channel patti on surface as required (S.No. 129 P-15).	910	per point	65520
2	16	Wiring for plug point with 3/029 PVC insulated wire in 20mm (3/4") channel patti on surface as required (S.I.No:130 P- No:15)	742	per point	11872
3	2	Wiring for call bell point with 3/029 PVC insulated wire in 20mm (3/4") channel patti on surface as required. (S.I.No:131 P- No:15)	1590	per point	3180
4	100	Providing & laying (MAIN or SUB MAIN) PVC insulated with size 2-7/029 copper conductor in 3/4" dia PVC conduit on surface (S.I.No:3 P- No:1)	171	P.Mtr	17100
5	30	Providing & laying (MAIN or SUB MAIN) PVC insulated with size 2-7/036 (4mm2) copper conductor in 3/4" dia PVC conduit on surface.	200	per Meter	6000
9	75	Providing & laying (MAIN or SUB MAIN) PVC insulated with size 2-7/044 (6mm2) copper conductor in 1" dia PVC conduit on surface (S.I.No:5 P- No:1)	305	P.Mtr	22875
7	72	Providing & fixing one way SP 5amp switch flush type(S.I.No:219 P- No:33)	54	P.No	3888
8	16	Providing & fixing two pin 5amp plug & socket (S.I.No:225 P- No:33)	83	P.No	1328
9	3	Providing & fixing three pin 10/15amp plug & socket flush type (S.I.No:226 P- No:33)	151	P.No	453
10	20	Providing & fixing circuit breaker 6,10,15,20, 30,40,50 & 63amp SP (TB-5S) on prepared board as required (S.I.No:202 P- No:30)	916	P.No	18320
8	2	Providing & fixing circuit breaker 3,5,10,15,20 & 30amp TP (XS-30NS[NB]) on prepared board as required. (S.I.No:205 P- No:31)	5301	Each	10602
12	1	Providing & fixing circuit breaker 15,20,30, 40,50,60,75 & 100amp TP (XS-100NS) on prepared board as required (S.I.No:207 P- No:31)	9261	P.No	9261
12	32	Providing & fixing Bakelite ceiling rose with two terminals (S.I.No:228 P- No:33)	72	P.No	2304
13	30	Providing & fixing Brass Battern holder c(S.I.No:232 P- No:33)	70	P.No	2100
14	30	Providing & laying (MAIN or SUB MAIN) PVC insulated with size 2-7/052 (10 mm2) copper conductor in 1" dia PVC conduit on surface (S.I.No:6 P- No:1)	428	P.Mtr	12840
TOTAL :-					187643

<u>PART "B" SCHEDULE ITEMS</u>					
1	4	P/F distribution metal board double shutter to accommodate circuit breakers including painting with enamel paint and for other simmlar job on surface (S.I.No:18 P- No:13)	907.96	P.Sft	3632
2	22	P/F mild steel bar fan clamp 15.8 mm (5/8")dia suitable for RCC roof (S.I.No:1 (c) P- No:14)	141.01	Each	3102
3	10	P/F wall bracket light fancy type superior quality including necessary electric connection and fixing on wall oe ceiling etc complete.(S.I.No:5 P- No:33)	497.00	Each	4970
4	10	P/Fenergy sever superior quality including fixing on existing holder etc complete.(S.I.No:6 P- No:33)	497.00	Each	4970
5	18	P/F Bulb 25 Watts	25.00	Each	450
6	2	P/F earthing set with 2x2x1/4" cooper plate burried in groud at a depth of 12" or less if water comes out from the ground level with salt and chorcoal ,etc,in/c.making the pit 12"deep by excavation of all type of soil. Earth plat to be connected with No:8	3610.04	Each	7220
7	22	P/F A.C ceiling fan regulator on metal board recessed in the walls column and covered with plastic sheet (S.I.No:2b P- No:14)	124.30	Each	2735
8	2	P/F AC or DC electric bell 200/250 volt 70MM. (S.I.No:21 P- No:11)	150.78	Each	301
9	2	P/F flush type electric bell bush button (S.I.No:23 P- No:12)	25.19	Each	50
10	10	P/F 1-40 wats tube light complete with 40 wats4.0" long rod chok , starter and putty with Phillips components including necessary electric connection and fixing on wall or ceiling etc complete. (S.I.No:1 P- No:33)	396.00	Each	3960
TOTAL					31391

Amount Total (CS:3)
 EDUCATION WORKS DIVISION
 SHIKARPUR.

EXECUTIVE ENGINEER
 EDUCATION WORKS DIVISION
 SHIKARPUR.

Part "A" %Above / Below _____ Total Amount _____

Part "B" %Above / Below _____ Total Amount _____

Total "A+B" _____

CONTRACTOR

BIDDING DATA

(This section should be filled in by the Engineer/Procuring Agency before issuance of the Bidding Documents).

(a). **Name of Procuring Agency:-** Executive Engineer (Education Works)
Division Shikarpur.

PROVINCIAL ADP SCHEMES (Electrical Works)

(b). **Brief Description of Works:-** ADP 282 UP-GRADATION OF MIDDLE SCHOOLS TO HIGH SCHOOLS & HIGH SCHOOL TO HIGHER SECONDARY SCHOOLS IN SINDH (2007-08 PROGRAMME).

GGMS HOTHU

(c). **Procuring Agency's address:-** Executive Engineer (Education Works) Division Shikarpur
Near GBHS No.II Shikarpur.

(d). **Estimated Cost:-** 0.200 (Millions).

(e). **Amount of Bid Security:-** 2% (Fill in lump sum amount or in % age of bid amount /estimated cost, but not exceeding 5%)

(f). **Period of Bid Validity (days):-** 60 Days (Not more than sixty days).

(g). **Security Deposit:-(including bid security):-** 10%
(in % age of bid amount /estimated cost equal to 10%)

(h). **Percentage, if any, to be deducted from bills:-** 7.50% Income tax

(i). **Deadline for Submission of Bids along with time :-** As Per NIT

(j). **Venue, Time, and Date of Bid Opening:-** Near GBHS II (Shikarpur As Per NIT).

(k). **Time for Completion from written order of commence: -** 06 Months

(L). **Liquidity damages:-** -NIL- (0.05 of Estimated Cost or Bid cost per day of delay, but total not exceeding 10%).



(M). **Deposit Receipt No:** _____ **Date:** _____ **Amount:Rs:** _____

Bank _____

(n) **D.R.NO:** _____ **DATED:** _____ **Amount 500/- (Rupees: Five Hundred only).**

(o). **Tender issued to Mr. / M/s** _____ **Govt: Contractor.**

EXECUTIVE ENGINEER
EDUCATION WORKS DIVISION
SHIKARPUR

BILL OF QUANTITIES

Description and Rate of Items based on Composite Schedule of Rates

NAME OF WORK :- UP-GRADATION OF MIDDLE SCHOOL TO HIGH SCHOOL IN SINDH 2007-08
 PROGRAMME @ GGMS HOTH TALUKA LAKHI. (INTERNAL ELECTRIFICATION)

Quantities	Description of item to be executed at site	Rate	Units	Amount
PART 'A' SCHEDULE ITEMS				
72	Wiring for light or fan point with 3/0.29 PVC insulated wire in 20mm (3/4") channel patti on surface as required (S.No. 129 P-15).	910	per point	65520
16	Wiring for plug point with 3/0.29 PVC insulated wire in 20mm (3/4") channel patti on surface as required (S.I.No:130 P- No:15)	742	per point	11872
2	Wiring for call bell point with 3/0.29 PVC insulated wire in 20mm (3/4") channel patti on surface as required. (S.I.No:131 P- No:15)	1590	per point	3180
100	Providing & laying (MAIN or SUB MAIN) PVC insulated with size 2-7/0.29 copper conductor or in 3/4" dia PVC conduit on surface (S.I.No:3 P- No:1)	171	P.Mtr	17100
30	Providing & laying (MAIN or SUB MAIN) PVC insulated with size 2-7/0.36 (4mm ² copper conductor in 3/4" dia PVC conduit on surface.	200	per Meter	6000
75	Providing & laying (MAIN or SUB MAIN) PVC insulated with size 2-7/0.44 (6mm ² copper conductor in 1" dia PVC conduit on surface (S.I.No:5 P- No:1).	305	P.Mtr	22875
72	Providing & fixing one way SP 5amp switch flush type(S.I.No:219 P- No:33)	54	P.No	3888
16	Providing & fixing two pin 5amp plug & socket (S.I.No:225 P- No:33)	83	P.No	1328
3	Providing & fixing three pin 10/15amp plug & socket flush type (S.I.No:226 P- No:33)	151	P.No	453
20	Providing & fixing circuit breaker 6,10,15,20, 30,40,50 & 63amp SP (TB-5S) on prepared board as required (S.I.No:202 P- No:30)	916	P.No	18320
2	Providing & fixing circuit breaker 3,5,10,15,20 & 30amp TP (XS-30NS[NB]) on prepared board as required. (S.I.No:205 P- No:31)	5301	Each	10602
1	Providing & fixing circuit breaker 15,20,30, 40,50,60,75 & 100amp TP (XS-100NS) on prepared board as required (S.I.No:207 P- No:31)	9261	P.No	9261
32	Providing & fixing Bakelite ceiling rose with two terminals (S.I.No:228 P- No:33)	72	P.No	2304
30	Providing & fixing Brass Battern holder c(S.I.No:232 P- No:33)	70	P.No	2100
30	Providing & laying (MAIN or SUB MAIN) PVC insulated with size 2-7/0.52 (10mm ² copper conductor in 1" dia PVC conduit on surface (S.I.No:6 P- No:1).	428	P.Mtr	12840
TOTAL :-				187643

PART 'B' SCHEDULE ITEMS				
4	P/F distribution metal board double shutter to accommodate circuit breakers including painting with enamel paint and for other similar job on surface (S.I.No:18 P- No:13)	907.96	P.Sft	3632
22	P/F mid steel bar fan clamp 15.8 mm (5/8")dia suitable for RCC roof (S.I.No:1 (c) P- No:14)	141.01	Each	3102
10	P/F wall bracket light fancy type superior quality including necessary electric connection and fixing on wall or ceiling etc complete.(S.I.No:5 P- No:33)	497.00	Each	4970
10	P/F energy sever superior quality including fixing on existing holder etc complete.(S.I.No:6 P- No:33)	497.00	Each	4970
18	P/F Bulb 25 Watts	25.00	Each	450
2	P/F earthing set with 2x2x1/4" cooper plate buried in ground at a depth of 12" or less if water comes out from the ground level with salt and charcoal etc,in c.making the pit 12"deep by excavation of all type of soil. Earth plat to be connected with No:8	3610.04	Each	7220
22	P/F A C ceiling fan regulator on metal board recessed in the walls column and covered with plastic sheet (S.I.No:2b P- No:14)	124.30	Each	2735
2	P/F A C or DC electric bell 200/250 volt 70MM. (S.I.No:21 P- No:11)	150.70	Each	301
2	P/F flush type electric bell bush button (S.I.No:23 P- No:12)	25.19	Each	50
10	P/F 1-40 watts tube light complete with 40 wats 4.0" long rod chok , starter and putty with Phillips components including necessary electric connection and fixing on wall or ceiling etc complete. (S.I.No:1 P- No:33)	396.00	Each	3960
TOTAL :-				31391

DRAUGHTSMAN
EDUCATION WORKS DIVISION
SHIKARPUR.
TOTAL (CSR:)

EXECUTIVE ENGINEER
EDUCATION WORKS DIVISION,
SHIKARPUR.

Part 'A' %Above / Below _____ Total Amount _____
 Part 'B' %Above / Below _____ Total Amount _____
 Total "A+B" _____

CONTRACTOR

BIDDING DATA

(This section should be filled in by the Engineer/Procuring Agency before issuance of the Bidding Documents).

- (a). **Name of Procuring Agency:-** Executive Engineer (Education Works)
Division Shikarpur.
- PROVINCIAL ADP SCHEMES (Electrical Works)**
- (b). **Brief Description of Works:-** ADP 409 ESTABLISHMENT OF GOVERNMENT BOYS/
GIRLS DEGREE COLLEGE MADEJI (Remaining Work)
- (c). **Procuring Agency's address:-** Executive Engineer (Education Works) Division Shikarpur
Near GBHS No.II Shikarpur.
- (d). **Estimated Cost:-** 0.500 (Millions).
- (e). **Amount of Bid Security:-** 2% (Fill in lump sum amount or in % age of bid amount /estimated cost, but not exceeding 5%)
- (f). **Period of Bid Validity (days):-** 60 Days (Not more than sixty days).
- (g). **Security Deposit:-(including bid security):-** 10%
(in % age of bid amount /estimated cost equal to 10%)
- (h). **Percentage, if any, to be deducted from bills:-** 7.50% Income tax
- (i). **Deadline for Submission of Bids along with time :-** As Per NIT
- (j). **Venue, Time, and Date of Bid Opening:-** Near GBHS II (Shikarpur As Per NIT).
- (k). **Time for Completion from written order of commence: -** 24 Months
- (L). **Liquidity damages:-** -NIL- (0.05 of Estimated Cost or Bid cost per day of delay, but total not exceeding 10%).
- (m). **Deposit Receipt No:** _____ **Date:** _____ **Amount:Rs:** _____
- Bank** _____
- (n) **D.R.NO:** _____ **DATED:** _____ **Amount 750/-**(Rupees: Seven Hundred Fifty only).
- (o). **Tender issued to Mr. / M/s** _____ **Govt: Contractor.**

EXECUTIVE ENGINEER
EDUCATION WORKS DIVISION
SHIKARPUR

BILL OF QUANTITIES

Discription and Rate of Items based on Composite Schedule of Rates

NAME OF WORK:- ESTABLISHMENT OF GOVERNMENT GIRLS DEGREE AT MADEJI (REMAINING WORK).

Item No.	Quantities	Description of item to be executed at site	Rate	Units	Amount
PART-A SCHEDULE ITEM					
1	80	Providing & laying (MAIN OR SUB MAIN) PVC insulated with size 2-7/0.52 (10mm 2) coper conductor in 1" dia PVC conduate	428.00	P.Mtr:	34,240
2	85	Providing and Fixing ceiling fans 56" size good quality.	3,185.00	P.No:	270,725
3	30	Providing & laying (MAIN OR SUB MAIN) PVC insulated & PVC sheeted with 4 core cooper conductor 600/1000 volts size 50mm ²	3,312.00	P.Mtr:	99,360
4	1	Providing and Fixing Circuit Breker 125,150,200 & 225 amp TP (XS 225NS) on prepared board as required.	25,541.00	P.No:	25,541
5	3	Providing and Fixing of stret light 250 watts (SON-T) having IP6+6 classification with 250w lamp, choke, capacitor & internal wiring, complete in all respect at the height with the help of hydraulic rane as per site requirement and instruction of EI	24,790.00	P.No:	74,370
				Total -A	504,236
PART-B OLD SCHEDULE ITEMS 2004					
1	2	Providing and Fixing 2-40 watts tubelights copmlete with 40 watts 4" long rad chowk etc complete.	1,677.00	P.No:	3,354
1	85	Errection of ceiling fans i/c wiring of down rad with 1/1.13mm (329 wire etc complete)	82.16	P.No:	6,984
				Total -B	10,338
				Total A+B	514,574

M. S. S.
DRAUGHTSMAN
EDUCATION WORKS DIVISION
SHIKARPUR.

[Signature]
EXECUTIVE ENGINEER
EDUCATION WORKS DIVISION
SHIKARPUR.

TOTAL (CSR:)

Part "A"

%Above / Below _____ Total Amount _____

Part "B"

%Above / Below _____ Total Amount _____

Total "A+B" _____

CONTRACTOR