

GOVERNMENT OF SINDH



IRRIGATION DEPARTMENT. UPPER PINYARI DIVISION HYDERABAD.

BIDDING DOCUMENTS.

NAME OF WORK: PROVIDING STONE PITCHING
ALONG PFL RD. 120 TO 130 IP SIDE
AND RD. 135 TO 140 NIP SIDE.

BIDDING DOCUMENTS FOR SMALL CONTRACTS BETWEEN
RS. 50.00 MILLION AND ABOVE.

Employer:- Sindh Irrigation Department, through Executive Engineer,
Upper Pinyari Division Hyderabad.

Issued to:- M/s _____

Amount of Documents Fee:- Rs. 2000/-

DR No. & Date:- _____

Executive Engineer,
Upper Pinyari Division,
Hyderabad.

GENERAL ORDINANCE

OF THE BOARD OF SUPERVISORS OF THE COUNTY OF ALBANY, NEW YORK

STANDARD FORMS OF SPECIFICATIONS FOR

(Civil Works - Large Works)

THIS S.B.S. shall be used for large works, as shown hereon, and the specifications.

**INSTRUCTIONS TO
PROCUREMENT AGENCIES**

INSTRUCTIONS TO PROCURING AGENCY

(Not to be included in bidding documents)

As stated in Clause IB.7 of the Instructions to Bidders, the complete bidding documents shall comprise of eleven items listed therein and any Addenda issued in accordance with Clause IB.9. The Standard Bidding Documents, in addition to Invitation for Bids, includes the following:

1. Instructions to Bidders.
2. Bidding Data.
3. General Conditions of Contract, Part I (GCC).
4. Special Conditions of Contract, Part II (SCC).
5. Specifications
6. Form of Bid and Appendices to Bid.
7. Bill of Quantities.
8. Form of Bid Security.
9. Form of Agreement.
10. Form of Performance Security, Mobilization Advance Guarantee, Indenture Security Bond and Integrity pact.
11. Drawings.

The Instructions to Bidders can be used as given. Procuring agency may have to make changes in the text under some special circumstances subject to provisions of Rules and Regulations.

General Conditions of Contract shall not be changed. Procuring agency may carry out changes in General Conditions of Contract through Special Conditions of Contract, as per provisions of Sindh Public Procurement Rules 2010, updated from time to time, in Province of Sindh. However, such changes in General Conditions shall be made with due care. Completion of the Forms and preparation of Bill of Quantities should be made as suggested hereinafter.

Procuring Agency is required to prepare the following documents for completion of the bidding documents:

- (i) Special Conditions of Contract Part-II (SCC)
- (ii) Specifications.
- (iii) Bill of Quantities.
- (iv) Drawings

A. Notice Inviting Tender

1. The "Notice Inviting Tender" is advertised in the newspapers shall appear in at least three widely circulated leading dailies of English, Urdu and Sindhi languages as well as on SPPRA Website as explained in the SPP Rules, 2010 (17) (2). All the blank spaces are to be filled in by the procuring agency.
2. The eligible bidders are defined in Clause IB.3 of Instructions to Bidders.
3. The notice shall be published so as to give the interested bidders, sufficient time for preparation and submission of bids which shall be minimum of 15 days for National

Competitive Bidding (NCB) and minimum of 45 days for International Competitive Bidding (ICB) SPP Rule 18.

4. Non-refundable tender fee for the sale of bidding documents shall be nominal so as to cover cost of photocopying or printing only SPP Rule 20. However, cost of mailing the documents on request of the interested bidder may be charged separately. Last date for the sale of the bidding documents is mentioned in the Notice Inviting Tender.
5. The procuring agency shall require the bidders to furnish a bid security not below one percent and not exceeding five percent of the bid price, which shall remain valid for a period of 28 days beyond the validity period for bids, in order to provide the procuring agency reasonable time to act, if the security is to be called, SPP Rule 37(1).
6. The venue and time of receipt of bids and the venue and time of opening of bids are to be mentioned in Notice Inviting Tender. Last date for the receipt and opening of bids shall be the same SPP Rule 41(1).
7. In IB 11.1 (b) of bidding data, procuring agency should list relevant information, which is considered vital at the time of post-qualification, when prequalification process is not followed. Subsequently, this information is required to be submitted along with bid and shall be verified by the procuring agency during evaluation process.
8. All blank spaces in the bidding data are to be filled in by the procuring agency to complete this document.
9. Referring to IB 19.2 (b) of bidding data, the Bid Reference Number should be the same as given in Notice Inviting Tenders and form of bid.

B. Instructions to Bidders and Bidding Data

1. If the works are not financed from a loan/credit, IB 2.1 of bidding data should be modified accordingly.
2. Procuring agency shall prepare the documents listed at Serial Nos. b, d, e, f, g, i, and k of IB 7.1 of Instructions to Bidders in order to complete the bidding documents comprising the Bid.
3. For completion of documents at Serial No. g and i, detailed instructions are given at Para C below.
4. Referring to IB 7.1 of bidding data, the period should be inserted as given in the bidding documents and Notice Inviting Tender (NIT).
5. In IB 11.1 (b) of bidding data, the bidder shall provide additional or updated information to the procuring agency regarding the post-qualification criteria as and when required.
6. Referring to IB 14.1 of bidding data, a bid validity period shall be specified therein, keeping in view the nature of the procurement, it shall not exceed 90 days in case of National Competitive Bidding (NCB) and 120 days in case of International Competitive Bidding (ICB) SPP Rule 38(1).

7. Referring to IB 15.1 of bidding data, the amount is to be filled in by the procuring agency; bid security shall not be below than one percent and not exceeding five percent of the bid price SPP Rule 37(1).

C. Form of Bid and Appendices to Bid

1. Form of Bid:

Only Bid Reference Number shall be filled in by the procuring agency (refer Para A.8 above). All other blanks spaces are to be filled in by the bidder.

2. Appendix-A to Bid:

- (a) The minimum amount of third party insurance should be assessed by the procuring agency and entered at Sr. No. 3.
- (b) The time for completion of the whole of the works shall be entered by the procuring agency at Sr. No. 5.
- (c) The amount of Liquidated Damages per day of delay shall be entered by the procuring agency at Sr. No. 7.

Amount of the Liquidated Damages for each day of delay in completion of the whole of the works, or if applicable, for any Section thereof, shall be (a sum equal to 10% of the estimated cost of the works divided by one-fourth of the number of days specified as completion time).

Formula: $LD \text{ (per day)} = 10\% \text{ of Estimated or Bid Cost} \div [0.25 \times \text{Time for completion (days)}]$.

- (d) The Defects Liability Period is to be entered by the procuring agency keeping in view the nature and size of the work at Sr. No. 7.

This is generally taken as 365 days/one year.

- (e) The minimum amount of Interim Payment Certificate should be determined by the procuring agency depending upon the size and duration of the works and to be entered at Sr. No 10.

3. Appendix-B to Bid:

Where foreign currency payments are foreseen; the entire Appendix-B to bid should be left blank to be filled in by the bidder.

Where no foreign currency payments are foreseen, the procuring agency should stamp this Appendix-B as "Not Used" and, referring to 1.1.4.6 and 13.4 of GCC, and state in SCC that all payments shall be in local currency only. Clause IB-13 should also be modified accordingly through the changes in bidding data.

4. **Appendix-C to Bid:**

(a) **National Competitive Bidding (NCB):**

Escalations on local funded projects/schemes shall be paid to the contractor only on following items with their base prices and sources shown in the bidding document at time of issuing NIT:-

- (i) Steel (ii) Cement (iii) Wood for Doors, windows & Partition walls
(iv) Bitumen (v) Bricks.

(b) **International Competitive Bidding (ICB):**

- (i) Contracts having duration of twelve months or more should be liable to price adjustment as per conditions of contract. Provided that the procuring agency may add or delete any item from the list given at the relevant appendix, as deemed appropriate.
- (ii) Blank spaces for weight-age of each cost item in column 3 of the table should be filled in by the procuring agency, while preparing the bidding documents.
- (iii) In case the price adjustable items are not covered in the Federal Bureau of Statistics, the base price and the source thereof shall be mentioned by the procuring agency and the corresponding column of the table should be amended accordingly.
- (iv) This mechanism shall be applicable only for price adjustment in local currency.
- (v) Price adjustment as mentioned above shall be applicable to all contracts including item rate, lump sum and %age quoted above or below on Composite Schedule of Rates (CSR), provided these provisions are part of the contract.

5. **Appendix-D to Bid:**

Bills for various items are given by way of example only. The procuring agency should prepare the Bill of Quantities (BoQs) appropriate to the works. In preparation of the Bill of Quantities, columns under (1), (2), (3) and (4) in item rate contract should be completed by the procuring agency, whereas, spaces under columns (5) and (6) as well as the totals at the bottom shall be left blank to be filled in by the bidder. But in case of Composite Schedule of Rates, all columns are to be filled by procuring agency, only percentage above or below are to be quoted by bidder.

Referring to Schedule of Day Work Rates for labour, materials and constructional plant, types of labour, materials and constructional plant under column (2) as well as quantities under column (4) are given by way of example only. The procuring agency should determine the types of labour, materials and constructional plant as well as the quantities thereof, estimated to be utilized, on day work basis

depending upon the nature of the works.
Percentage for overhead and profit on labour and materials, and the total amounts should be left blank to be filled in by the bidder.

Day Work summary is to be left blank to be filled in by the bidder.

6. **Appendix-E to Bid:**

If the procuring agency requires partial completion of the works by sections (for example Parts-A, B, C etc.), these should be identified and time for completion thereof, are to be specified, and the blank spaces may be filled in by the procuring agency.

7. **Appendix-F to Bid:**

The procuring agency may expand the requirements as stated in this Appendix, keeping in view the requirements of the works.

8. **Appendix-G to Bid:**

It pertains to the list of major equipments to be provided by the bidder if applicable. All blank spaces are to be filled in by the bidder.

9. **Appendix-H to Bid:**

The bidder has to provide details about camps and housing facilities. Procuring agency may modify the requirements as stated in this Appendix, keeping in view requirements of the works.

10. **Appendix-I to Bid:**

The bidder has to provide list of sub-contractors along with the details of works assigned. The blank spaces are to be filled in by the bidder.

11. **Appendix-J to Bid:**

The bidder has to provide the estimated value of work to be executed in the period mentioned therein. The blank spaces are to be filled in by the bidder.

12. **Appendix-K to Bid:**

The bidder has to provide the organizational chart for supervisory staff and labour. The blank spaces are to be filled in by the bidder.

13. **Appendix-L to Bid:**

Procuring agency shall provide the Integrity Pact form duly signed, stamped and submit the same along with the bid.

D. Forms

1. Bid Security:

Procuring agency, before issuing the bidding documents, should fill in following blank spaces:

- (a) Amount/ Percentage of bid security, in words as well as figures, which should be the same as provided at Sub-Para A.5 above.
- (b) Bid Reference Number should be the same as per Sub-Para B.7 above.
- (c) Standard Forms of Securities provided in this document are to be issued by a scheduled bank.

E. Special Conditions of Contract

1. Name and full address of the procuring agency as well as that of the Engineer in charge or in case a consultant is hired by the procuring agency, then Consultant's Engineer, as the case may be, should be filled in by the procuring agency in the blank spaces provided under Sub-Para (a) (i) and (iv) of Sub-Clause 1.1 of SCC.
2. Referring to first paragraph of Sub-Clause 3.1 of GCC, information as applicable is provided there under.
3. Referring to Sub-Clause 1.5 of GCC, the procuring agency may add, in the order of priority, such other documents which form part of the contract.
4. Referring to 8.3 of GCC, the procuring agency should specify the form in which the programme is to be submitted by the bidder, e.g., Critical Path Method (CPM), Bar Chart or Programme Evaluation and Review Technique (PERT).
5.
 - (a) Referring to Sub-Clause 5.3 of GCC, if the procuring agency desires the Bidder to use the services of nominated subcontractor(s), the procuring agency should make necessary provisions of provisional sums and provide blank spaces to be filled in the percentage rate(s) and estimated amounts, resulting there from in Appendix-D to Bid. The blank spaces for the rate(s) and the estimated amount(s) shall be filled in by the bidder.
 - (b) Suitable text referring to such provisions should be added in SCC.

If provisional sums and Day Work are not to be provided, then same should be mentioned in special conditions of contract.

6. Mobilization Advance/Advance Payment:

Procuring agency shall extend mobilization advance to the contractor *on submission of Bid Bond/ Bank Guarantee.*

7. Referring to 20.6 of GCC, the procuring agency should state the venue of Arbitration, which should be located within the province of Sindh and according to Arbitration Act, 1940 (up dated from time to time).
8. Addresses of the procuring agency and the Engineer or in case a consultant is hired

by the procuring agency, then Consultant's Engineer, as the case may be, are to be entered by the procuring agency to completely fill in the blanks in Sub-Clause 1.3.

F. Specifications.

To be prepared and incorporated by the procuring agency.

(Precise and clear specifications are prerequisite for bidders to respond realistically and competitively to the requirements of the procuring agency without qualifying or conditioning their bids. In the context of both national and international competitive bidding, the specifications must be drafted to permit the widest possible competition and, at the same time, present a clear statement of the required standards of materials, plant, other supplies, and workmanship to be provided. Only if this is done, the objectives of economy, efficiency and equality in procurement will be realized, responsiveness of bids be ensured, and the subsequent task of bid evaluation be facilitated. The specifications should require that all materials, plant, and other supplies to be incorporated in the works are new, unused, of the most recent or current models, and incorporate all recent improvements in design and materials unless provided otherwise in the contract. A clause setting out the scope of the works is often included at the beginning of the specifications, and it is customary to give a list of the drawings. Where the contractor is responsible for the design of any part of the permanent works, the extent of his obligations must be stated.

Specification shall be generic and shall not include references to brand names, model numbers, catalogue numbers or similar classifications. However, if the procuring agency is convinced that the use of or a reference to a brand name or catalogue number is essential to complete an otherwise incomplete specification, such use or reference shall be qualified with the words "or equivalent".

Care must be taken in drafting specifications to ensure that they are not restrictive. In the specification of standards for materials, plant, other supplies, and workmanship, recognized international standards should be used as much as possible. The specifications shall consider all site conditions, but not limited to seismic and weather conditions, and environmental impact. Where other particular standards are used, whether national or other standards, the specifications should state that materials, plant, other supplies, and workmanship meeting other recognised standards, and which ensure equal performance, to the mentioned standards, will also be acceptable.)

G. Drawings

To be prepared and incorporated by the procuring agency.

TABLE OF CONTENTS

CONTENTS		Page No.
INVITATION FOR BIDS		
	Form	4
INSTRUCTIONS TO BIDDERS		5
		6
A.	General	
	IB.1 Scope of Bid	7
	IB.2 Source of Funds	7
	IB.3 Eligible Bidders	7
	IB.4 One Bid Per Bidder	8
	IB.5 Cost of Bidding	8
	IB.6 Site Visit	8
B.	Bidding Documents	
	IB.7 Contents of Bidding Documents	9
	IB.8 Clarification of Bidding Documents	9
	IB.9 Amendment of Bidding Documents	9
C.	Preparation of Bids	
	IB.10. Language of Bid	10
	IB.11 Documents Accompanying the Bid	10
	IB.12 Bid Prices	11
	IB.13 Currencies of Bid and Payment	12
	IB.14 Bid Validity	12
	IB.15 Bid Security	13
	IB.16 Alternate Proposals by Bidder	13
	IB.17 Pre-Bid Meeting	14
	IB.18. Format and Signing of Bid	14
D.	Submission of Bids	
	IB.19 Sealing and Marking of Bids	15
	IB.20 Deadline for Submission of Bids	15
	IB.21 Late Bids	16
	IB.22 Modification, Substitution and Withdrawal of Bids	16

E.	Bid Opening and Evaluation	
	IB.23 Bid Opening	16
	IB.24 Process to be Confidential	17
	IB.25 Clarification of Bids	17
	IB.26 Examination of Bids and Determination of Responsiveness	17
	IB.27 Correction of Errors	18
	IB.28 Evaluation and Comparison of Bids	18
F.	Award of Contract	
	IB.29 Award	19
	IB.30 Procuring Agency's Right to Accept any Bid and to Reject any or all Bids	19
	IB.31 Notification of Award	20
	IB.32 Performance Security	20
	IB.33 Signing of Contract Agreement	20
	IB.34 General Performance of the Bidders	21
	IB.35 Integrity Pact	21
	IB.36 Instructions Not Part of Contract	21
	IB.37 Arbitration	21

BIDDING DATA	22
---------------------	-----------

FORM OF BID AND APPENDICES TO BID	27
------------------------------------------	-----------

FORM OF BID	28
Appendix-A to Bid : Special Stipulations	30
Appendix-B to Bid : Foreign Currency Requirements	31
Appendix-C to Bid : Price Adjustment (Under Clause 70)	32
Appendix-D to Bid : Bill of Quantities	33
Appendix-E to Bid : Proposed Construction Schedule	51
Appendix-F to Bid : Method of Performing the Work	52
Appendix-G to Bid : List of Major Equipment – Related Items	53
Appendix-H to Bid : Construction Camp and Housing Facilities	55
Appendix-I to Bid : List of Subcontractors	56
Appendix-J to Bid : Estimated Progress Payments	57
Appendix-K to Bid : Organization Chart of the Supervisory Staff and Labour	58
Appendix-L to Bid : Integrity Pact	59

FORMS

BID SECURITY	61
PERFORMANCE SECURITY	63
CONTRACT AGREEMENT	65
MOBILIZATION ADVANCE GUARANTEE	67
INDENTURE BOND FOR SECURED ADVANCE	69

PART-I: GENERAL CONDITIONS OF CONTRACT	74
-----------------------------------------------	-----------

PART-II: SPECIAL CONDITIONS OF CONTRACT	147
------------------------------------------------	------------

SPECIFICATIONS	168
-----------------------	------------

DRAWINGS	169
-----------------	------------

**INVITATION
FOR BIDS**

NOTICE INVITING TENDERS

Federal/Provincial/Local Government Funds/ Loans / Grant No: _____
Date: _____
Bid Reference No: _____

1. The Executive Engineer, Upper Jhelum Barrage (the
(Name of Procuring Agency)
"Procuring Agency") has received/ applied for loan/grant/funds from the
Government of Punjab towards the cost of Provision of Water Supply to
(Name of Funding Agency/GOP/Provincial Government/Any Other) (Name of Project/Scheme) Area 135/14
and it is intended that part of the proceeds of the loan/grant/funds will be applied to the
eligible payments under the contract for the _____
(Brief description of the Works)
Bidding is open to all interested bidders.
2. Procuring agency invites sealed bids from interested firms or persons licensed by the Pakistan Engineering Council (PEC) in the category _____ or above for the works and in discipline _____ and registered with relevant tax authorities. A foreign bidder is entitled to bid only in a joint venture with a Pakistani Firm in accordance with the relevant provisions of PEC bye-laws.
3. Bidders may obtain information by acquiring the bidding documents (BD) from the Office of the procuring agency, up to _____ (Insert the date and time) at
B- No. 47, Civil Line, Wazirpur
(Mailing Address)
4. A complete set of BD may be purchased by an interested bidder on submission of a written application to the above office and upon payment of a non-refundable fee of Rs. 500/-
(Insert Amount)
5. All bids must be accompanied by a bid security in the amount of Rs. 16,72,000/-
(Rupees one million, four thousand seven hundred and seventy two thousand or an equivalent amount in a freely convertible _____ currency, and _____ must be delivered to _____
(Indicate Address and Exact Location)
at or before 3 PM hours, on 16/5/2015 (Date). Bids will be opened at 3 PM hours on the same day, in the presence of bidder's representatives who choose to attend at the same address. (Indicate address and exact location if it differs).
6. Procuring agency reserves right to annul the bidding process and reject all bids or proposals, as per SPP Rules 2010.

[Note: the bids shall be opened not later than one hour after the deadline for submission of bids]

**INSTRUCTIONS
TO
BIDDERS**

INSTRUCTIONS TO BIDDERS

(Note: These Instructions to Bidders along with bidding data will not be part of the Contract and will cease to have effect once the contract is signed.)

A. GENERAL

IB.1 Scope of Bid

- 1.1 Procuring agency as defined in the bidding data hereinafter called "the procuring agency" wishes to receive bids for the construction and completion of works as described in these bidding documents, and summarized in the bidding data hereinafter referred to as the "Works".
- 1.2 The successful bidder will be expected to complete the works within the time specified in Appendix-A to Bid.

IB.2 Source of Funds

- 2.1 Procuring agency has received/allocated/ applied for loan/grant/ Federal/ Provincial/Local Government funds from the source(s) indicated in the bidding data in various currencies towards the cost of the project /scheme specified in the bidding data, and it is intended that part of the proceeds of this loan/grant/funds will be applied to eligible payments under the contract for which these bidding documents are issued.

IB.3 Eligible Bidders

- 3.1 This Invitation for Bids is open to all interested bidders who are eligible under provisions of Sindh Public Procurement Rules as mentioned below and the criteria given in the Notice Inviting Tender (NIT)/ Bidding Document.

Firms and individuals, national or international, may be allowed to bid for any project where international competitive bidding is feasible. Any conditions for participation shall be limited to those that are essential to ensure the bidder's capability to fulfill the contract in question.

- (a) Bidders may be excluded if;
 - (i) as a matter of law or official regulations, commercial relations are prohibited with the bidder's country by the federal government in case of ICB, or
 - (ii) a firm is blacklisted/ debarred by the procuring agency and the matter has been reported to the Authority, subject to Rule 30 of Sindh Public Procurement Rules 2010.

- (b) Government-owned enterprises or institutions may participate only if they can establish that they are;
 - (i) legally and financially autonomous, and
 - (ii) operate under commercial law.

Provided that where government-owned universities or research centers in the country are of a unique and exceptional nature, and their participation is critical to project implementation, they may be allowed to participate; and

Bidders shall include all those contractors who are registered or incorporated in Pakistan, irrespective of the nationality of their owners and professional staff, or

- (c) Bidders are:-
 - (i) pre-qualified with procuring agency for particular project/scheme;
 - (ii) registered with Pakistan Engineering Council in particular category and discipline,
 - (iii) registered with relevant tax authorities (income/sales tax, wherever applicable)

IB.4 One Bid per Bidder

- 4.1 Each bidder shall submit only one bid either by himself, or as a partner in a joint venture. A bidder who submits or participates in more than one bid (other than alternatives pursuant to Clause IB.16) will be disqualified.

IB.5 Cost of Bidding

- 5.1 The bidders shall bear all costs associated with the preparation and submission of their respective bids, and the procuring agency will in no case be responsible or liable for those costs, regardless of the conduct or outcome of the bidding process.

IB.6 Site Visit

- 6.1 The bidders are advised to visit and examine the site of works and its surroundings and obtain all information that may be necessary for preparing the bid and entering into a contract for construction of the works. All cost in this respect shall be at the bidder's own expense.
- 6.2 The bidders and any of their personnel or agents will be granted permission by the procuring agency to enter upon his premises and lands for the purpose of such inspection, but only upon the express condition that the bidders, their personnel and agents, will release and indemnify the procuring agency, his personnel and agents from and against all liability in respect thereof and will be responsible for death or personal injury, loss of or damage to property and any other loss, damage, costs and

expenses incurred as a result of such inspection.

B. BIDDING DOCUMENTS

IB.7 Contents of Bidding Documents (SSP RULE 21)

7.1 The bidding documents, in addition to invitation for bids, are those stated below and should be read in conjunction with any addenda issued in accordance with Clause IB.9.

- a. Instructions to Bidders.
- b. Bidding Data.
- c. General Conditions of Contract, Part-I (GCC).
- d. Special Conditions of Contract, Part-II (SCC)
- e. Specifications.
- f. Form of Bid and Appendices to Bid.
- g. Bill of Quantities (Appendix-D to Bid).
- h. Form of Bid Security.
- i. Form of Contract Agreement.
- j. Forms of Performance Security, Mobilization Advance Guarantee, Integrity Pact and Indenture bond for secured advance.
- k. Drawings.

7.2 The bidders are expected to examine carefully the contents of all the above documents. Failure to comply with the requirements of bid submission will be at the bidder's own risk. Pursuant to Clause IB.26, bids which are not substantially responsive to the requirements of the BD will be rejected.

IB.8 Clarification of Bidding Documents (SSP RULE 23(1)):

Any interested bidder requiring any clarification(s) in respect of the bidding documents may notify the procuring agency in writing at the procuring agency's address indicated in the Invitation for Bids/NIT. Procuring agency will respond to any request for clarification provided they are received at least five calendar days prior to the date of opening of bid.

Provided that any clarification in response to query by any bidder; shall be communicated to all parties who have obtained bidding documents.

IE.9 Addendum/Modification of Bidding Documents:

- 9.1 At any time prior to the deadline for submission of bids, the procuring agency may, for any reason, whether at his own initiative or in response to a clarification requested by a interested bidder, modify the bidding documents by issuing addendum.
- 9.2 Any addendum thus issued shall be part of the bidding documents pursuant to sub-clause IB 7.1 hereof and shall be communicated in writing to all bidders. Interested bidders shall acknowledge receipt of each addendum in writing to the procuring agency.
- 9.3 To afford bidders reasonable time in which to take an addendum into account in

preparing their bids, the procuring agency may extend the deadline for submission of bids in accordance with IB.20

C. PREPARATION OF BIDS

IB.10 Language of Bid

10.1 The bid and all correspondence and documents related to the bid exchanged by a bidder and the procuring agency shall be in the language stipulated in the bidding data and Special Conditions of the Contract. Supporting documents and printed literature furnished by the bidders may be in any other language provided the same are accompanied by an accurate translation of the relevant parts in the bid language, in which case, for purposes of evaluation of the bid, the translation in bid language shall prevail.

IB.11 Documents Accompanying the Bid

11.1 Each bidder shall:

- (a) submit a written authorization on the letterhead of the bidding firm, authorizing the signatory of the bid to act for and on behalf of the bidder;
- (b) update the information indicated and listed in the bidding data and previously submitted with the application for prequalification, and continue to meet the minimum criteria set out in the prequalification documents, which as a minimum, would include the following:
 - (i) Evidence of access to financial resources along with average annual construction turnover;
 - (ii) Financial predictions for the current year and the following two years, including the effect of known commitments;
 - (iii) Work commitments since prequalification;
 - (iv) Current litigation information; and
 - (v) Availability of critical equipment.

And

- (c) furnish a technical proposal taking into account the various Appendices to Bid specially the following:

Appendix-E to Bid	Proposed Construction Schedule
Appendix-F to Bid	Method of Performing the Work
Appendix-G to Bid	List of Major Equipment
Appendix-K to Bid	Organization Chart for Supervisory Staff

and other pertinent information such as mobilization programme etc;

11.2 Bids submitted by a joint venture of two (2) or more firms shall comply with the following requirements:

- (a) one of the joint venture partners shall be nominated as being in charge; and

- this authorization shall be evidenced by submitting a power of attorney signed by legally authorized signatories of all the joint venture partners;
- (b) the bid, and in case of a successful bid, the Form of Contract Agreement shall be signed by the authorized partner so as to be legally binding on all partners;
 - (c) the partner-in-charge shall always be duly authorized to deal with the procuring agency regarding all matters related with and/or incidental to the execution of works as per the terms and Conditions of Contract and in this regard to incur any and all liabilities, receive instructions, give binding undertakings and receive payments on behalf of the joint venture;
 - (d) all partners of the joint venture shall at all times and under all circumstances be liable jointly and severally for the execution of the contract in accordance with the contract terms and a statement to this effect shall be included in the authorization mentioned under Sub-Para (a) above as well as in the Form of Bid and in the Form of Contract Agreement (in case of a successful bid);
 - (e) a copy of the agreement entered into by the joint venture partners shall be submitted with the bid stating the conditions under which it will function, its period of duration, the persons authorized to represent and obligate it and which persons will be directly responsible for due performance of the contract and can give valid receipts on behalf of the joint venture, the proportionate participation of the several firms forming the joint venture, and any other information necessary to permit a full appraisal of its functioning. No amendments / modifications whatsoever in the joint venture agreement shall be agreed to between the joint venture partners without prior written consent of the procuring agency;
 - (f) submission of an alternative Letter of Intent to execute a Joint Venture Agreement shall be mandatory.

11.3 Bidders shall also submit proposals of work methods and schedule, in sufficient detail to demonstrate the adequacy of the bidders' proposals to meet the technical specifications and the completion time referred to sub-clause IB 1.2 hereof.

IB.12 Bid Prices

- 12.1 Unless stated otherwise in the bidding documents, the contract shall be for the whole of the works as described in IB 1.1 hereof, based on the unit rates or prices submitted by the bidder or percentage quoted above or below on the rates of Composite Schedule of Rates (CSR), as the case may be.
- 12.2 The bidders shall fill in rates and prices for all items of the works described in the Bill of Quantities. Items against which no rate or price is entered by a bidder will not be paid for by the procuring agency when executed and shall be deemed to be covered by rates and prices for other items in the Bill of Quantities. In case of Composite Schedule of Rates, if the bidder fails to mention the percentage above or below, it shall be deemed to be at par with the rates of Composite Schedule of Rates.
- 12.3 The bid price submitted by the contractor shall include all rates and prices including

the taxes. All duties, taxes and other levies payable by the contractor under the contract, or for any other cause during the currency of the execution of the work or otherwise specified in the contract as on the date seven days prior to the deadline for submission of bids.

Additional / reduced duties, taxes and levies due to subsequent additions or changes in legislation shall be reimbursed / deducted as per Sub-Clause 13.7 of the General Conditions of Contract Part-I.

- 12.4 The rates and prices quoted by the bidders are subject to adjustment during the performance of the contract in accordance with the provisions of Clause 13.7 of GCC. The bidders shall furnish the prescribed information for the price adjustment formulae in Appendix-C to Bid, and shall submit with their bids such other supporting information as required under the said Clause. Adjustment in prices quoted by bidders shall be allowed as per Sub-Para 4(ii) of Section C of Instructions to bidders and bidding data.

IB.13 Currencies of Bid and Payment

- 13.1 The unit rates and the prices shall be quoted by the bidder entirely in Pak rupees. A bidder expecting to incur expenditures in other currencies for inputs to the works supplied from outside the procuring agency's country (referred to as the "Foreign Currency Requirements") shall indicate the same in Appendix-B to Bid. The proportion of the bid price (excluding Provisional Sums) needed by him for the payment of such Foreign Currency Requirements either (i) entirely in the currency of the bidder's home country or, (ii) at the bidder's option, entirely in Pak rupees provided always that a bidder expecting to incur expenditures in a currency or currencies other than those stated in (i) and (ii) above for a portion of the foreign currency requirements, and wishing to be paid accordingly, shall indicate the respective portions in the bid.
- 13.2 The rates of exchange to be used by the bidder for currency conversion shall be the selling rates published and authorized by the State Bank of Pakistan prevailing on the date, 07 (seven) days prior to the deadline for submission of bids. For the purpose of payments, the exchange rates used in bid preparation shall apply for the duration of the contract.

IB.14 Bid Validity

- 14.1 Bids shall remain valid for the period stipulated in the bidding data from the date of opening of bid specified in clause IB.23.
- 14.2 In exceptional circumstances, prior to expiry of the original, the procuring agency may request the bidders to extend the period of validity for a specified additional period, which shall not be for more than one third of the original period of bid validity. The request and the responses thereto, shall be made in writing. A bidder may refuse the request without the forfeiture of the bid security. In case, a bidder agreed to the request, shall not be required or permitted to modify the bid, but will be required to extend the validity of the bid security for the period of the extension, and in compliance with Clause IB.15 in all respects.

IB.15 Bid Security

- 15.1 Each bidder shall furnish, as part of the bid, a bid security in the amount stipulated in the bidding data in Pak Rupees or an equivalent amount in a freely convertible currency.
- 15.2 The bid security shall be at the option of the bidder, in the form of deposit at call, Pay order or a bank guarantee issued by a Scheduled Bank in Pakistan or from a foreign bank duly counter guaranteed by a Scheduled Bank in Pakistan in favour of the procuring agency, which should commensurate with the bid validity period. The bank guarantee for bid security shall be acceptable in the manner as provided at Annexure BS-1
- 15.3 Any bid not accompanied by an acceptable bid security shall be rejected by the procuring agency as non-responsive.
- 15.4 Bid security shall be released to the unsuccessful bidders once the contract has been signed with the successful bidder or the validity period has expired.
- 15.5 The bid security of the successful bidder shall be returned when the bidder has furnished the required Performance Security and signed the Contract Agreement.
- 15.6 The bid security may be forfeited:
 - (a) if the bidder withdraws his bid except as provided in sub- clause IB 22.1;
 - (b) if the bidder does not accept the correction of his bid price pursuant to sub- clause IB 27.2 hereof; or
 - (c) In the case of successful bidder, if he fails within the specified time limit to:
 - (i) furnish the required Performance Security; or
 - (ii) sign the Contract Agreement.

IB.16 Alternate Proposals/Bids

- 16.1 Each bidder shall submit only one bid either by himself, or as a member of a joint venture, until and unless they have been requested or permitted for alternative bid, then he has to purchase separate bidding documents and alternate bid shall be treated as separate bid.
- 16.2 Alternate proposals are allowed only for procurement of works where technical complexity is involved and more than one designs or technical solutions are being offered. Two stage two envelope bidding procedure will be appropriate when alternate proposal is required.
- 16.3 Alternate bid(s) shall contain (a) relevant design calculations; (b) technical specifications; (c) proposed construction methodology; and (d) any other relevant details / conditions, provided that the total sum entered on the Form of Bid shall be

that which represents complete compliance with the bidding documents.

IB.17 Pre-Bid Meeting

- 17.1 Procuring agency may, on his own motion or at the request of any bidder, hold a pre-bid meeting to clarify issues and to answer any questions on matters related to the bidding documents. The date, time and venue of pre-bid meeting, if convened, shall be communicated to all bidders. All bidders or their authorized representatives shall be invited to attend such a pre-bid meeting at their own expense.
- 17.2 The bidders are requested to submit questions, if any, in writing so as to reach the Procuring agency not later than seven (7) days before the proposed pre-bid meeting.
- 17.3 Minutes of the pre-bid meeting, including the text of the questions raised and the replies given, will be transmitted without delay to all bidders. Any modification of the bidding documents listed in sub- clause IB 7.1 hereof, which may become necessary as a result of the pre-bid meeting shall be made by the procuring agency exclusively through the issue of an Addendum pursuant to Clause IB.9 and not through the minutes of the pre-bid meeting.
- 17.4 Absence at the pre-bid meeting will not be a cause for disqualification of a bidder.

IB.18 Format and Signing of Bid

- 18.1 Bidders are particularly directed that the amount entered on the Form of Bid shall be for performing the contract strictly in accordance with the bidding documents.
- 18.2 All appendices to bid are to be properly completed and signed.
- 18.3 Alteration is not to be made neither in the form of bid nor in the Appendices thereto except in filling up the blanks as directed. If any such alterations be made or if these instructions be not fully complied with, the bid may be rejected.
- 18.4 Each bidder shall prepare by filling out the forms without alterations and shall provide an original copy along with photocopies as per the requirement of the procuring agency specified in the bidding data. The original as well as copies of the document shall be clearly marked as "ORIGINAL" and "COPY", as the case may be. If there is any discrepancy between original and copy (ies) then the original shall prevail.
- 18.5 The original and all copies of the bid shall be typed or written in indelible ink (in the case of copies, Photostats are also acceptable) and shall be signed by a person(s) duly authorized to sign on behalf of the bidder pursuant to sub- clause IB 11.1(a) hereof. All pages of the bid shall be initialed and stamped by the person(s) signing the bid.
- 18.6 The bid shall contain no alterations, omissions or additions, except to comply with instructions issued by the procuring agency, or as are necessary to correct errors made by the bidder. Such corrections shall be initialed by the person(s) signing the bid.
- 18.7 Bidders shall indicate in the space provided in the Form of Bid their full and proper

postal addresses at which notices may be legally served on them and to which all correspondence in connection with their bids and the contract is to be sent.

18.8 Bidders should retain a copy of the bidding documents as their file copy.

D. SUBMISSION OF BIDS

IB.19 Sealing and Marking of Bids

19.1 Each bidder shall submit his bid as under:

- (a) ORIGINAL and _____ COPIES of the bid shall be separately sealed and put in separate envelopes and marked as such.
- (b) The envelopes containing the ORIGINAL and COPIES shall be put in one sealed envelope and addressed as given in sub – clause IB 19.2 hereof.

19.2 The inner and outer envelopes shall:

- (a) be addressed to the procuring agency at the address provided in the bidding data;
- (b) bear the name and identification number of the contract as defined in the bidding data; and
- (c) provide a warning not to open before the time and date for bid opening, as specified in the bidding data.

19.3 In addition to the identification required in sub- clause IB 19.2 hereof, the inner envelope shall indicate the name and postal address of the bidder to enable the bid to be returned unopened in case it is declared "late" pursuant to Clause IB.21

19.4 If the outer envelope is not sealed and marked as above, the procuring agency will assume no responsibility for the misplacement or premature opening of the Bid.

IB.20 Deadline for Submission of Bids

- 20.1 (a) Bids must be received by the procuring agency at the address specified not later than the time and date stipulated in the bidding data,
- (b) Bids with charges payable will not be accepted, nor will arrangements be undertaken to collect the bids from any delivery point other than that specified above. Bidders shall bear all expenses incurred in the preparation and delivery of bids. No claims shall be entertained for refund of such expenses,
- (c) Where delivery of a bid is by mail and the bidder wishes to receive an acknowledgment of receipt of such bid, he shall make a request for such acknowledgment in a separate letter attached to but not included in the sealed bid package,

- (d) Upon request, acknowledgment of receipt of bids will be provided to those making delivery in person or by messenger.

20.2 The Procuring Agency may, at its discretion, extend the deadline for submission of bids by issuing an amendment in accordance with IB 09. In such case, all rights and obligations of the procuring agency and the bidders shall remain the same as mentioned in the original deadline.

IB.21 Late Bids

- (a) any bid received by the procuring agency after the deadline for submission of bids prescribed in to clause IB 20 shall be returned unopened to such bidder.
- (b) delays in the mail, person in transit, or delivery of a bid to the wrong office shall not be accepted as an excuse for failure to deliver a bid at the proper place and time. It shall be the bidder's responsibility to submit the bid in time.

IB.22 Modification, Substitution and Withdrawal of Bids

- 22.1 Any bidder may modify, substitute or withdraw his bid after bid submission provided that the modification, substitution or written notice of withdrawal is received by the procuring agency prior to the deadline for submission of bids.
- 22.2 The modification, substitution, or notice for withdrawal of any bid shall be prepared, sealed, marked and delivered in accordance with the provisions of Clause IB.19 with the outer and inner envelopes additionally marked "MODIFICATION", "SUBSTITUTION" or "WITHDRAWAL" as appropriate.
- 22.3 No bid may be modified by a bidder after the deadline for submission of bids except in accordance with to sub - clauses IB 22.1 and IB 27.2.
- 22.4 Withdrawal of a bid during the interval between the deadlines for submission of bids and the expiration of the period of bid validity specified in the Form of Bid may result in forfeiture of the bid security in pursuance to clause IB 15.

E. BID OPENING AND EVALUATION.

IB.23 Bid Opening

- 23.1 Procuring agency will open the bids, including withdrawals, substitution and modifications made pursuant to Clause IB.22, in the presence of bidders' representatives who choose to attend, at the time, date and location stipulated in the bidding data. The bidders or their representatives who are in attendance shall sign an attendance sheet.
- 23.2 Envelopes marked "MODIFICATION", "SUBSTITUTION" or "WITHDRAWAL" shall be opened and read out first. Bids for which an acceptable notice of withdrawal has been submitted pursuant to clause IB.22 shall not be opened.
- 23.3 Procuring agency shall read aloud the name of the bidder, total bid price and price of

any Alternate Proposal(s), if any, discounts, bid modifications, substitution and withdrawals, the presence or absence of bid security, and such other details as the procuring agency may consider appropriate, and total amount of each bid, and of any alternative bids if they have been requested or permitted, shall be read aloud and recorded when opened.

- 23.4 Procuring Agency shall prepare minutes of the bid opening, including the information disclosed to those present in accordance with the sub-clause IB.23.3.

IB.24 Process to be Confidential. (SPP Rule 53)

- 24.1 Information relating to the examination, clarification, evaluation and comparison of bid and recommendations for the award of a contract shall not be disclosed to bidders or any other person not officially concerned with such process before the announcement of bid evaluation report in accordance with the requirements of Rule 45, which states that Procuring agencies shall announce the results of bid evaluation in the form of a report giving reasons for acceptance or rejection of bids. The report shall be hoisted on website of authority and that of procuring agency if its website exists and intimated to all bidders at least seven (7) days prior to the award of contract. The announcement to all bidders will include table(s) comprising read out prices, discounted prices, price adjustments made, final evaluated prices and recommendations against all the bids evaluated. Any effort by a bidder to influence the procuring agency's processing of bids or award decisions may result in the rejection of such bidder's bid. Whereas, any bidder feeling aggrieved, may lodge a written complaint as per Rule 31; however mere fact of lodging a complaint shall not warrant suspension of the procurement process.

IB.25 Clarification of Bid (SPP Rule 43)

- 25.1 To assist in the examination, evaluation and comparison of bids, the procuring agency may, at its discretion, ask any bidder for clarification of the bid, including breakdowns of unit rates. The request for clarification and the response shall be in writing but no change in the price or substance of the bid shall be sought, offered or permitted except as required to confirm the correction of arithmetic errors discovered by the procuring agency in the evaluation of the bids in accordance with clause IB 28.

IB.26 Examination of Bids and Determination of Responsiveness

- 26.1 Prior to the detailed evaluation of bids, the procuring agency will determine whether the bidder fulfills all codal requirements of eligibility criteria given in the tender notice such as registration with tax authorities, registration with PEC (where applicable), turnover statement, experience statement, and any other condition mentioned in the NIT and bidding document. If the bidder does not fulfill any of these conditions, it shall not be evaluated further.
- 26.2 Once found to be fulfilling the eligibility criteria, as mentioned in sub-clause 26.1, the bids of eligible bidders will be evaluated for technical responsiveness as per specification and criteria given in the bidding documents. Technical and financial evaluations may be carried out in accordance with single stage-single one envelope, single stage-two envelopes, two stage or two stage-two envelopes bidding procedures,

depending on the selection procedure adopted by the procuring agency.

26.3 A bid will be considered technically responsive if it (i) has been properly signed; (ii) is accompanied by the required bid security; and (iii) conforms to all the terms, conditions and specifications of the bidding documents, without material deviation or reservation. A material deviation or reservation is one (i) which affect in any substantial way the scope, quality or performance of the works; (ii) which limits in any substantial way, inconsistent with the bidding documents, the procuring agency's rights or the bidder's obligations under the contract; or (iii) adoption/rectification whereof would affect unfairly the competitive position of other bidders presenting substantially responsive bids.

26.4 If a bid has major deviations to the commercial requirements and technical specifications will be considered technically non responsive. As a general rule, major deviations are those that if accepted, would not fulfill the purposes for which the bid is requested, or would prevent a fair comparison or affect the ranking of the bids that are compliant with the bidding documents.

(A). Major (material) Deviations include:-

- (i) has been not properly signed;
- (ii) is not accompanied by the bid security of required amount and manner;
- (iii) stipulating price adjustment when fixed price bids were called for;
- (iv) failing to respond to specifications;
- (v) failing to comply with Mile-stones/Critical dates provided in Bidding Documents;
- (vi) sub-contracting contrary to the Conditions of Contract specified in Bidding Documents;
- (vii) refusing to bear important responsibilities and liabilities allocated in the Bidding Documents, such as performance guarantees and insurance coverage;
- (viii) taking exception to critical provisions such as applicable law, taxes and duties and dispute resolution procedures;
- (ix) a material deviation or reservation is one :
 - (a) which affect in any substantial way the scope, quality or performance of the works;
 - (b) adoption/rectification whereof would affect unfairly the competitive position of other bidders presenting substantially responsive bids.

(B) Minor Deviations

Bids that offer deviations acceptable to the Procuring Agency and which can be assigned a monetary value may be considered substantially responsive at least as to the issue of fairness. This value would however be added as an adjustment for evaluation purposes only during the detailed evaluation process.

26.5 If a bid is not substantially responsive, it will be rejected by the procuring agency, and may not subsequently be made responsive by correction or withdrawal of the non-conforming deviation or reservation.

IB.27 Correction of Errors before Financial Evaluation

- 27.1 Bids determined to be substantially responsive will be checked by the procuring agency for any arithmetic errors. Errors will be corrected by the procuring agency as follows:
- (a) where there is a discrepancy between the amounts in figures and in words, the amount in words will govern; and
 - (b) where there is a discrepancy between the unit rate and the line item total resulting from multiplying the unit rate by the quantity, the unit rate as quoted will govern, unless in the opinion of the procuring agency there is an obviously gross misplacement of the decimal point in the unit rate, in which case the line item total as quoted will govern and the unit rate will be corrected.
- 27.2 The amount stated in the Form of Bid will be adjusted by the procuring agency in accordance with the above procedure for the correction of errors and with the concurrence of the bidders. The amount thus corrected shall be considered as binding upon the bidder. If the bidder does not accept the corrected bid price, his bid will be rejected, and the bid security shall be forfeited in accordance with sub-clause IB 15.6(b) hereof.

IB.28 Financial Evaluation and Comparison of Bids

- 28.1 The procuring agency will evaluate and compare only the Bids determined to be substantially responsive in accordance with clause IB 26.
- 28.2 In evaluating the Bids, the procuring agency will determine for each bid the evaluated bid price by adjusting the bid price as follows:
- (a) making any correction for errors pursuant to clause IB 27;
 - ✓(b) excluding provisional sums (if any), for contingencies in the Summary Bill of Quantities, but including competitively priced Day work; and
 - (c) making an appropriate adjustment for any other acceptable variation or deviation.
- 28.3 The estimated effect of the price adjustment provisions of the conditions of contract, applied over the period of execution of the contract, shall not be taken into account in bid evaluation.
- 28.4 If the bid of the successful bidder is seriously unbalanced in relation to the procuring agency's estimate of the cost of work to be performed under the contract, the procuring agency may require the bidder to produce detailed price analyses for any or all items of the Bill of Quantities to demonstrate the internal consistency of those prices with the construction methods and schedule proposed. After evaluation of the price analyses, the procuring agency may require that the amount of the Performance Security set forth in clause IB.32 be increased at the expense of the successful bidder to a level sufficient to protect the procuring agency against financial loss in the event of default of the successful bidder under the contract.

28.5 Bidders may be excluded if involved in **“Corrupt and Fraudulent Practices”** means either one or any combination of the practices given below SPP Rule 2(q);

- (i) **“Coercive Practice”** means any impairing or harming, or threatening to impair or harm, directly or indirectly, any party or the property of the party to influence the actions of a party to achieve a wrongful gain or to cause a wrongful loss to another party;
- (ii) **“Collusive Practice”** means any arrangement between two or more parties to the procurement process or contract execution, designed to achieve with or without the knowledge of the procuring agency to establish prices at artificial, noncompetitive levels for any wrongful gain;
- (iii) **“Corrupt Practice”** means the offering, giving, receiving or soliciting, directly or indirectly, of anything of value to influence the acts of another party for wrongful gain;
- (iv) **“Fraudulent Practice”** means any act or omission, including a misrepresentation, that knowingly or recklessly misleads, or attempts to mislead, a party to obtain a financial or other benefit or to avoid an obligation;
- (v) **“Obstructive Practice”** means harming or threatening to harm, directly or indirectly, persons or their property to influence their participation in a procurement process, or affect the execution of a contract or deliberately destroying, falsifying, altering or concealing of evidence material to the investigation or making false statements before investigators in order to materially impede an investigation into allegations of a corrupt, fraudulent, coercive or collusive practice; or threatening, harassing or intimidating any party to prevent it from disclosing its knowledge of matters relevant to the investigation or from pursuing the investigation, or acts intended to materially impede the exercise of inspection and audit rights provided for under the Rules.

28.6 Evaluation Report (SPP Rule 45)

After the completion of evaluation process, as described in clauses IB 27 and IB 28, the procuring agency shall announce the results of bid evaluation in the form of report (available on the website of the authority) giving reasons for acceptance and rejection of bid. The report shall be hoisted on website of the authority and that of procuring agencies if its website exists and intimated to all bidders at least seven (7) days prior to the award of contract.

F. AWARD OF CONTRACT

IB.29 Award (SPP Rule 49)

29.1 Subject to clauses IB 30 and IB 34 and provision of the rule: The procuring agency shall award the contract to the bidder whose bid has been determined to be substantially responsive to the bidding documents, and who has offered the lowest evaluated bid, but not necessarily the lowest submitted price, within the original or extended period of bid validity. Provided that such bidder has been determined to be eligible in accordance with the provisions of clause IB 03 and qualify pursuant to sub-clause IB 29.2.

- 29.2 Procuring agency, at any stage of the bid evaluation, having credible reasons for or having *prima facie* evidence of any deficiency(ies) in contractor's capacities, may require the contractor to provide information concerning their professional, technical, financial, legal or managerial competence whether already pre-qualified or not for the said project.

Provided, that such qualification shall only be laid down after recording reasons thereof, in writing. They shall form part of the records of that bid evaluation report.

IB.30 Procuring Agency's Right to reject all Bids or Annul/Cancellation the Bidding Process (SPP Rule 25)

Notwithstanding clause IB 29 and provision of the rule: (1) A procuring agency reserves may cancel the bidding process at any time prior to the acceptance of a bid or proposal; (2) The procuring agency shall incur no liability towards bidders solely by virtue of its invoking sub -rule (1); (3) Intimation of the cancellation of bidding process shall be given promptly to all bidders and bid security shall be returned along with such intimation; (4) The procuring agency shall, upon request by any of the bidders, communicate to such bidder, grounds for cancellation of the bidding process, but is not required to justify such grounds.

IB.31. Notification/Publication of the Award of Contract (SPP Rule 25).

- 31.1 Prior to expiry of the period of bid validity, including extension, prescribed by the procuring agency, the procuring agency shall notify the successful bidder in writing ("Letter of Acceptance") that his bid has been accepted. This letter shall mention the sum which the procuring agency will pay to the contractor in consideration of the execution and completion of the works by the contractor as prescribed by the contract (hereinafter and in the conditions of contract called the "Contract Price").
- 31.2 No negotiation with the bidder having evaluated as lowest responsive or any other bidder shall be permitted, however, procuring agency may hold meetings to clarify any item in the bid evaluation report.
- 31.3 The notification of award and its acceptance by the bidder will constitute the formation of the contract, binding the procuring agency and the bidder till signing of the formal Contract Agreement.
- 31.4 Upon furnishing by the successful bidder of a Performance Security and signing of the contract, the procuring agency will promptly notify the name of the successful bidder to all bidders and return their bid securities accordingly.
- 31.5 Within seven days of the award of contract, procuring agency shall publish on the website of the Authority and on its own website, if such a website exists, the results of the bidding process, identify the bid through procurement identifying numbers, and the following information:

- (1) Evaluation Report;
- (2) Form of Contract and letter of Award;
- (3) Bill of Quantities or Schedule of Requirement.

31.6 Debriefing (SPP Rule 51).

- (a) A bidder may ask the procuring agency for reasons for non acceptance of his bid and may request for a debriefing meeting and procuring agency shall give him the reasons for such non acceptance, either in writing or by holding a debriefing meeting with such a bidder.
- (b) The requesting bidder shall bear all the costs of attending such a debriefing.

IB.32 Performance Security (SPP Rule 39)

- 32.1 The successful bidder shall furnish to the procuring agency a Performance Security in the form of pay order or demand draft or bank guarantee, and the amount stipulated in the bidding data and the Conditions of Contract within a period of 28 days after the receipt of Letter of Acceptance.
- 32.2 Failure of the successful bidder to comply with the requirements of Sub-clause IB.32.1 or clauses IB 33 or IB 35 shall constitute sufficient grounds for the annulment of the award and forfeiture of the bid security.
- 32.3 Validity of performance security shall extend at least ninety days beyond the date of completion of contract, or as mentioned in the bidding data to cover defects liability period or maintenance period subject to final acceptance by the procuring agency.

IB.33 Signing of Contract Agreement (SPP Rule 39)

- 33.1 Within 14 days from the date of furnishing of acceptable Performance Security under the Conditions of Contract, the procuring agency will send the successful bidder the Contract Agreement in the form provided in the bidding documents, incorporating all agreements between the parties.
- 33.2 The formal Agreement between the procuring agency and the successful bidder shall be executed within 14 days of the receipt of the Contract Agreement by the successful bidder from the procuring agency.
- 33.3 A procurement contract shall come into force when the procuring agency requires signs contract, the date on which the signatures of both the procuring agency and the successful bidder are affixed to the written contract. Such affixing of signatures shall take place within the time prescribed in the bidding documents.

Provided that the procuring agency may reduce the maximum time limit for signing of contract, as and when required, and shall be mentioned in the bidding documents.

33.4 Stamp Duty.

The formal Agreement between the Procuring Agency and the successful bidder shall be duly stamped at rate of ---% of bid price (updated from time to time) stated in Letter of Acceptance

IB.34 General Performance of the Bidders

Procuring agency may in case of consistent poor performance of the contractor and his failure to remedy the underperforming contract may take such action as may be deemed appropriate under the circumstances of the case including the rescinding the contract and/or black listing of such contractor and debarring him from participation in future bidding process.

IB.35 Integrity Pact (SPP Rule 89)

The bidder shall sign and stamp the Integrity Pact provided at Appendix-L to the bidding documents for all Provincial/Local Government procurement contracts exceeding Rupees ten million. Failure to provide such Integrity Pact shall make the bidder non-responsive.

IB.36 Instructions not Part of Contract

Bids shall be prepared and submitted in accordance with these Instructions which are provided to assist bidders in preparing their bids, and do not constitute part of the bid or the Contract Documents.

IB.37 Arbitration (SPP Rule 34)

Any dispute that is not amicably resolved shall be finally settled, unless otherwise specified in the Contract, under the Arbitration Act 1940 updated from time to time and would be held anywhere in the Province of Sindh at the discretion of procuring agency.

**BIDDING
DATA**

NOTES ON BIDDING DATA

This Section is intended to assist the procuring agency in providing the specific information in relation to corresponding clauses in Instructions to Bidders and should be prepared to suit each individual contract.

The procuring agency should provide in the bidding data information and requirements specific to the circumstances of the procuring agency, the processing of the bid, the applicable rules regarding bid price and currency, and the bid evaluation criteria that will apply to the bids. In preparing this section, the following aspects should be checked:

- (1) Information that specifies and complements the provisions of section; Instruction to Bidders must be incorporated.
- (2) Amendments and/or supplements, if any, to the provisions of Instructions to Bidders, necessitated by the circumstances of each individual contract, can be introduced only in this section since Instructions to Bidders will remain unchanged.

Contact/Bidding Data

(This section should be filled in by the procuring agency before issuance of the bidding documents.) The following specific data for the works to be tendered shall complement, amend, or supplement the provisions in the Instructions to Bidders. Wherever there is a conflict, the provisions herein shall prevail over those in the Instructions to Bidders.

[Instructions are provided, as needed, in italics.]

Instructions to Bidders

Clause Reference

- 1.1 Name and address of the procuring agency:
- 1.2 Name of the Project and Summary of the works:
[Insert brief summary, including relationship to other contracts under the Project. If the works are to be tendered in separate contracts, describe all the contracts.]
- 2.1 Name of the Borrower/Source of Financing/Funding Agency/Funding Source;
[Insert the ADP No: (in case of PSDP) / name of Borrower and statement of relationship with the procuring agency, if different from the Borrower. This insertion should correspond to the information provided in the Invitation for Bids.]
- 2.1 Amount and Type of Financing/Scheme Cost and Allocated Funds.
- 8.1 Time limit for clarification:
[Minimum number of days to seek clarification by the interested bidder may be inserted as no later than 5 working days prior to last date of submission.]
- 10.1 Bid language:
[The same language in which the bidding documents are written in English, should be used in National/ International Competitive Bidding.]
- 11.1 (a) Prequalification Information to be updated (where applicable):
[Indicate what items of information submitted with application for prequalification is to be updated. It may include but not limited to (i) Evidence of access to financial resources, (ii) latest status of financial resources commitment for two years (including the current year), (iii) works awarded during the interim period, (iv) availability of essential critical equipment, and (v) information about litigation presently in process.]
- 11.1 (b) Furnish and Technical Proposal *(in case of two envelope method)* or Company Profile in single stage single envelope:
The bidder has to submit a technical proposal in sufficient detail to demonstrate the adequacy of the bid in meeting requirements for timely completion of the works.

- 13.1 Bidders to quote entirely in Pak. rupees but specify the percentages of foreign currency they require, if applicable.
- 14.1 Period of Bid Validity:
[Insert number of days after the deadline for bid opening. This period should be realistic, allowing sufficient time to evaluate the Bids, bearing in mind the complexity of works, and the time required for obtaining references, clarifications, clearances, and approvals (including the Financing Agency's "No Objection" if it is a bilateral or multilateral funding agency financed project) and for notification of the award. Normally the validity period should not exceed 90 days for NCB and 120 days for ICB.]
- 15.1 Amount of Bid Security:
[This amount should be the same as also quoted in the Invitation for Bids. To avoid disclosure of bid price, a fixed sum should be specified, in preference to a percentage of the bid price. The sum has to be within the limits of 5% of estimated cost. The percentage should be lower in case of larger works and higher in case of smaller works, but not less than 1% and not exceed the limit of 5%.]
- 17.1 Venue, time, and date of the pre-Bid meeting:
[Insert address of venue, or indicate that the meeting will not take place. The meeting should take place not later than 7 days in case of NCB and no later than 15 days in case of ICB before the deadline for bid submission. It should take place concurrently with the site visit, if any (see Sub-Clause IB-6).]
- 18.4 Number of copies of the bid to be completed and returned:
[Usually one original and copies (number to be specified by the procuring agency)]
- 19.2 (a) Procuring Agency's address for the purpose of bid submission:
[Should match the receiving address provided in the Invitation for Bids.]
- (b) Name and Identification Number of the Contract:
- 20.1 (a) Deadline for submission of bids:
[The time and date should be the same as that given in the Invitation for Bids unless subsequently amended pursuant to IB.20.2.]
- (b) Venue, time, and date of bid opening:
[Date should be the same as that given for the deadline for submission of Bids [IB.20] but time for opening of bids shall be at least thirty minutes after the time for the deadline for submission of bids, but not later than one hour].
- 32.1 Standard form and amount of Performance Security acceptable to the procuring agency:

[Select the kind of Performance Security (bank guarantee, call deposit, pay order), and indicate the amount/percentage. A bank guarantee has to be unconditional as given in the sample form given with the bidding document. An amount not more than 10 percent of the contract price is commonly specified for bank guarantees. This percentage should match with that stipulated in Appendix-A to Bid.]

32.3 Stamp duty

_____ % will be paid by successful bidder as stamp duty.
[% will depend upon the rules]

**FORM OF BID
AND
APPENDICES TO BID**

FORM OF BID

Bid Reference No. _____
 (Name of Contract/Work)

To: _____

Having examined the bidding documents including Instructions to Bidders, Bidding Data, and Conditions of Contract, Specifications, Drawings and Bill of Quantities and Addenda Nos. _____ for the execution of the above-named work, we/I, the undersigned, offer to execute and complete the work and remedy any defects therein in conformity with the Conditions of Contract, Specifications, Drawings, Bill of Quantities and Addenda for the sum of Rs. _____ (Rupees) or such other sum as may be ascertained in accordance with the said conditions.

- 2 We/I understand that all the Appendices attached hereto form part of this bid.
- 3 As security for due performance of the undertakings and obligations of this bid, we/I submit herewith a bid security in the amount of Rupees _____ (Rs. _____) drawn in your favour or made payable to procuring agency and valid for a period of _____ days beginning from the date, bid is opened.
- 4 We/I undertake, if our bid is accepted, to commence the works and to complete the whole of the works comprised in the contract within the time stated in Appendix-A to Bid.
- 5 We/I agree to abide by this bid for the period of _____ days from the date fixed for opening the same and it shall remain binding upon us and may be accepted at any time before the expiration of that period.
- 6 Unless and until a formal Agreement is prepared and executed, this bid, together with your written acceptance thereof, shall constitute a binding contract between us.
- 7 We do hereby declare that the bid is made without any collusion, comparison of figures or arrangement with any other bidder for the works.

We understand that you are not bound to accept the lowest or any bid you may receive.

- 9 We undertake, if our/my bid is accepted, to execute the Performance Security referred to in Clause 10 of Conditions of Contract for the due performance of the Contract.
- 10 We confirm, if our bid is accepted, that all partners of the joint venture shall be liable jointly and severally for the execution of the Contract and the composition or the constitution

of the joint venture shall not be altered without the prior consent of the procuring agency.
(Please delete this in case of Bid form a single bidder)

in the capacity of _____ duly authorized to sign Bids for and on behalf of

Dated this _____ day of _____ 20____

Signature: _____

(Name of Bidder in Block Capitals)
(Seal)

Address: _____

Witness:

Signature: _____
Name: _____

Address: _____

Occupation: _____

SPECIAL STIPULATIONS

Clause

Conditions of Contract

1.	Engineer representing Consulting Firm hired by the procuring agency to issue variation in case of emergency.	3.1	Up to 2% of the contract price stated in the Letter of Acceptance.
2.	Amount of Performance Security	4.2	Up to 10% of contract price. Total amount including performance security and retention money deducted from bills should not exceed 10% of contract price stated in the Letter of Acceptance.
3.	Time for Furnishing Programme	8.3	Within 42 days from the date of receipt of Letter of Acceptance.
4.	Minimum amount of Third Party Insurance	18.3	Rs. _____ per occurrence with number of occurrences unlimited.
5.	Time for Commencement	8.1	Within 14 days from the date of receipt of Engineer's Notice to Commence, this shall be issued within fourteen (14) days after signing of Contract Agreement.
6.	Time for Completion (works & sections)	8.2 & 10.2	_____ days from the date of receipt of Engineer's Notice to Commence.
7.	Amount of Liquidity Damages/Delay Damages/Penalties	8.7	-----Damages per day (are to be mentioned) but total amount will not be more than 10% of contract Price.
8.	Defects Liability Period	11.1	_____ days from the effective date of Taking Over Certificate.
9.	Percentage of Retention Money	14.2	10 % of the amount of Interim/Running Payment Certificate.
10.	Limit of Retention Money	14.2	5 % of Contract Price stated in the Letter of Acceptance.
11.	Minimum amount of Interim/Running Payment Certificates	14.2	Rs. _____
12.	Time of Payment from delivery of Engineer's Interim/Running Payment Certificate to the procuring agency.	14.7	30 days in case of local currency or 42 days in case of foreign funded projects.
13.	Mobilization Advance.	14.2	10% of Contract Price stated in the Letter of Acceptance.

FOREIGN CURRENCY REQUIREMENTS

1. The bidder may indicate herein below his requirements of foreign currency (if any), with reference to various inputs to the works.
2. Foreign Currency Requirement as percentage of the bid price excluding Provisional Sums _____%.
3. Table of Exchange Rates

Unit of Currency	Equivalent in Pak. Rupees
Australian Dollar	_____
Euro	_____
Japanese Yen	_____
U.K. Pound	_____
U.S. Dollars	_____
_____	_____
_____	_____

**PRICE ADJUSTMENT UNDER CLAUSE 70/13.8
OF CONDITIONS OF CONTRACT**

A. Weight ages or coefficients are used for price adjustment.

The source of indices and the weight ages or coefficients for use in the adjustment formula under Clause 13.8 shall be as follows:

(To be filled by the procuring agency)

Cost Element	Description	Weight ages	Applicable index
1	2	3	4
(i)	Fixed Portion	0.350	
(ii)	Local Labor		Government of Pakistan (GoP) Federal Bureau of Statistics (FBS) Monthly Statistical Bulletin.
(iii)	Cement - in bags		" " "
(iv)	Reinforcing Steel		" " "
(v)	High Speed Diesel (HSD)		" " "
(vi)	Bricks		" " "
(vii)	Bitumen		" " "
(viii)			
	Total	1.000	

Notes:

- 1) Indices for "(ii)" to "(vii)" are taken from the Government of Pakistan Federal Bureau of Statistics, Monthly Statistical Bulletin. The base cost indices or prices shall be those applying 15 days prior to the latest day for submission of bids. Current indices or prices shall be those applying 28 days prior to the last day of the billing period.
- 2) Any fluctuation in the indices or prices of materials other than those given above shall not be subject to adjustment of the Contract Price.
- 3) Fixed portion shown here is for typical road project, procuring agency to determine the weight age of Fixed Portion considering only those cost elements having cost impact of seven (7) percent or more on his specific project.

B When Escalation is allowed on the materials only.
 Price adjustment on following items shall be allowed:

Cost Element	Description	Base price	Applicable index
1	2	3	4
(i)	Cement - in bags		Government of Pakistan (GoP) Federal Bureau of Statistics (FBS) Monthly Statistical Bulletin. " " "
(ii)	Reinforcing Steel		" " "
(iii)	Bricks		" " "
(iv)	Bitumen		" " "
(v)	Wood (Composite item)		" " "
	Total five items.		

BILL OF QUANTITIES

- A. Preamble**
1. The Bill of Quantities shall be read in conjunction with the Conditions of Contract, Specifications and Drawings.
 2. The quantities given in the Bill of Quantities are estimated and provisional, and are given to provide a common basis for bidding. The basis of payment will be the actual quantities of work executed and measured by the Contractor and verified by the Engineer and valued at the rates and prices entered in the priced Bill of Quantities, where applicable, and otherwise at such rates and prices as the Engineer may fix as per the Contract (in case of item not mentioned in Bill of Quantities).
 3. The rates and prices entered in the priced Bill of Quantities shall, except insofar as it is otherwise provided under the contract include all costs of contractor's plant, labour, supervision, materials, execution, insurance, profit, taxes and duties, together with all general risks, liabilities and obligations set out or implied in the contract, or for all duties, taxes and other levies payable by the contractor under the contract, or for any other cause, as on the date 14 days prior to deadline for submission of Bids in case of ICB/NCB respectively, shall be included in the rates and prices and the total bid price submitted by the bidder.
 4. A rate or price shall be entered against each item in the priced Bill of Quantities, whether quantities are stated or not. The cost of items against which the contractor will have failed to enter a rate or price shall be deemed to be covered by other rates and prices entered in the Bill of Quantities and shall not be paid separately.
 5. The whole cost of complying with the provisions of the Contract shall be included in the items provided in the priced Bill of Quantities, and where no items are provided, the cost shall be deemed to be distributed among the rates and prices entered for the related items of the works.
 6. General directions and description of work and materials are not necessarily repeated nor summarised in the Bill of Quantities. References to the relevant sections of the bidding documents shall be made before entering prices against each item in the priced Bill of Quantities.
 7. Provisional sums included and so designated in the Bill of Quantities shall be expended in whole or in part at the direction and discretion of the Engineer in accordance with sub-clause 13.5 of Part I, General Conditions of Contract.

BILL OF QUANTITIES (SAMPLE)

B. Work Items. (Road /PHE Work)*

1. The Bill of Quantities contains the following Bills and Items:

Bill No. 1	-	Earthworks
Bill No. 2	-	Hard Crust and Surface Treatment
Bill No. 3	-	Culverts and Bridges
Bill No. 4	-	Subsurface Drains, Pipe Laying and Man holes
Bill No. 5	-	Tube wells, Pump houses and Compound wall
Bill No. 6	-	Miscellaneous Items

Day work Schedule
Summary Bill of Quantities

2. Bidders shall price the Bill of Quantities in Pakistani Rupees only.

**Procuring Agency can add and delete the Items as per its requirement.*

BILL OF QUANTITIES (SAMPLE)***B. Work Items (Buildings)**

1. The Bill of Quantities contains the following Bills and Items:

Bill No. 1	-	Plinth and Foundation.
Bill No. 2	-	Ground floor.
Bill No. 3	-	First and Subsequent Floors.
Bill No. 4	-	Internal Water Supply and Sanitary Fittings.
Bill No. 5	-	Internal Electrification.
Bill No. 6	-	Miscellaneous Items
Bill No. 7	-	External Development

Day work Schedule
Summary Bill of Quantities

2. Bidders shall price the Bill of Quantities in Pakistani Rupees only.

* *Procuring Agency can add and delete the Items as per its requirement*

BILL OF QUANTITIES (SAMPLE)
Bill No. 1 Earthworks/Plinth and Foundation

Item	Description	Unit	Quantity	Rate		Amount Rupees
				Rupees figures	Rupees in words	
1	2	3	4	5		6
101						
102						
103						
104						
105						
106						
Total for Bill No. 1 (Carried forward to Summary Page)						

BILL OF QUANTITIES (SAMPLE)

Bill No. 2 Hard Crust and Surface Treatment /Ground Floor.

Item	Description	Unit	Quantity	Rate		Amount Rupees
				Rupees in figures	Rupees in words	
1	2	3	4	5		6
201						
202						
203						
204						
205						
206						
Total for Bill No. 2 (Carried forward to Summary Page)						

BILL OF QUANTITIES (SAMPLE)

Bill No. 3 Culverts and Bridges/First and Subsequent Floors

Item	Description	Unit	Quantity	Rate		Amount
				Rupees in figures	Rupees in words	Rupees
1	2	3	4	5		6
301						
302						
303						
304						
305						
306						
Total for Bill No. 3 (Carried forward to Summary Page)						

BILL OF QUANTITIES (SAMPLE)

Bill No. 4 Subsurface Drains/ Pipe Laying and Man holes/Internal water Supply and Sanitary Fittings

Item	Description	Unit	Quantity	Rate		Amount
				Rupees in figures	Rupees in words	Rupees
1	2	3	4	5		6
401						
402						
403						
404						
205						
406						
Total for Bill No. 4						
(Carried forward to Summary Page)						

Schedule "B"

NAME OF WORK: PROVIDING STONE PITCHING ALONG PFL

RD 120 TO 130 NIP SIDE AND 135 TO 140 NIP SIDE

Quantity	item	Rate	Per	Amount
4:0970 Cft.	1. Excavation in foundaion of buildings bridges and other structure i/c dag-belling dressing, refilling around structure with excavated earth watering and ramming lead upto one chain and lift upto 5 feet. (b) Ordinary Soil. [S.Item No.18(b) P.No.04]	3176.25	%o Cft.	1,305,343.97
114280 Cft.	2. Extra for slush or daidal i/c dewatering [S.Item No.16. P.No.04]	2420.00	%o Cft.	276,557.10
9253.44 Cft.	3. Cement concrete plain i/c placing, comp- acting, finishing and curing complete (i/c screening and washing of stone aggregate without shuttering). (f) Ratio 1:3:6	12595.00	% Cft	1,165,470.96
9020.25 Cft.	(h) Ratio 12:4 [S.Item No.5(f)(h) P.No.18]	14429.25	% Cft	1,301,554.42
3119.58 Cft.	4. FOUNDATION AND PLINTH Coursed Rubble masonry i/c hammer dressing (d) In cement sand mortar (iii) Ratio 1:6 [S.Item No.2(d)(iii), P.No.32]	25321.00	% Cft	789,908.85
22:44.64 Cft.	5. SUPER STRUCTURE. Coursed Rubble masonry hammer dressED. (d) In cement sand mortar (iii) Ratio 1:6 [S.Item No.4(d)(iii), P.No.33]	26288.46	% Cft	6,031,793.39
16:000 Cft.	6. Stone filling dry hand packed as filling behind walls or in pitching and apron. [S.Item No.6, P.No.34]	2684.00	% Cft	4,348,080.00
25:947 Sft	7. Formation dressing and preparing sub-grade (a) slope [S.Item No.6(a) P.No.34]	453.75	% Sft	1,147,749.05
				<u>16,366,457.75</u>

Quantity	item	Rate	Per	Amount
				16,366,457.75
406421 C ft.	8. Stone Pitching i/c sub-base wirth hammer dressed stone on surface laid in courses i/c carriage of material within 3 chains [S.Item No.23 P.No.35]	5377.63	% Cft	21,855,827.01
2593 Sft.	9. Erection and removal of centering for RCC or plain cement concrete owrks of deodar wood (2nd class). (a) (i) Horizontal [S.Item No.18(a)(i) P.No.21]	7693.13	% Sft	199,461.32
1:133640 Cft.	10. Borrowpit excavation undressed lead Upto 100 ft (a) Ordinary soil. (a) Ordinary Soil. [S.Item No.3(a) P.No.1]	2117.50	%o Cft.	2,400,482.70
1:133640 Cft.	11. Carriage of 100 Cft/5 ton of all materail like stone aggregate, spawal, coal lime surkhi etc. B.G.Rail fastening joints and crossing bridges girders pipe sheet rail MS bars etc or 1000 Nos bricks 10"x3"x3" or 1000 Nos tiles 12"x6"x2" or 150 cft timber or 1000 Nos maund or fuel wood by trolly or any other means owned by contractors 3 Miles [S.Item No.1, P.No.1 Sch. Carriage]	407.00	% Cft	4,613,914.79
1133640 Cft.	12. Dressing and levelling of earth work to designed section etc complete. (b) Ordinary or hard soil. [S.Item No.11(b), P.No.3]	187.55	% Cft	212,614.18
96) Days	13. Full hire charges of Pumping set per day inclusive wages of driver and assistant, fuel or electric energy plate form required for placing pump at in lower depth with suction and delivery pipes for pumping out water i/c erection and dismantling after completion of the job [S.Item No.23(iv), P.No.53 PHEW Vol:III]	1000.00	P.Day	960,000.00

 46,608,757.75

Quantity	item	Rate	Per	Amount
				46,608,757.75
3835 Hours	14. For pumping set about 10 HP but not less 5 HP (Beyond 8 hours) [S.Item No.24(iv), P.No.53 PHEW Vol:III]	188.00	P.Hour	720,980.00
	Total Rs.			47,329,737.75

NB: No above premium is allowed on item No. 11.

Contractor

Executive Engineer
Upper Pinyari Division
Hyderabad

SECTION OF STONE PITCHING, PROFILE AND C/FORT ALONG P.F.L

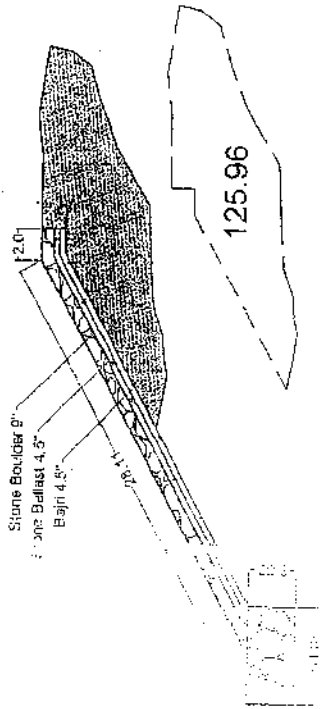

Stone Pitching

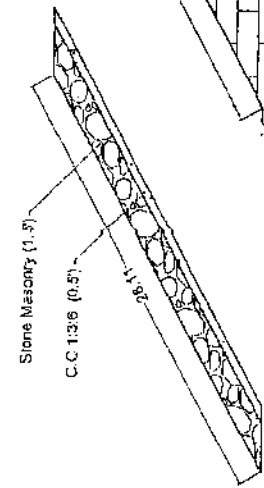

Profile

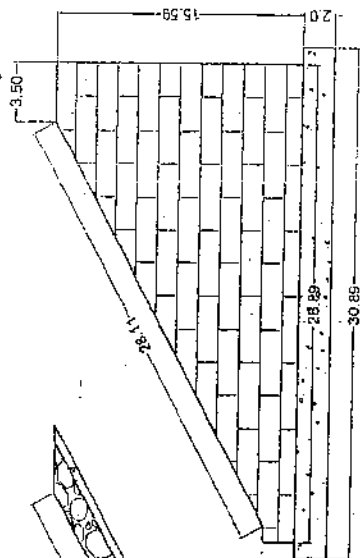

C/Fort

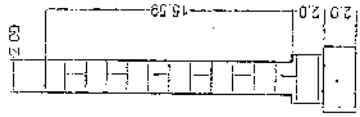

C/Fort

SUB ENGINEER

ASSISTANT EXECUTIVE ENGINEER
DARRO SUB DIVISION

[Signature]
EXECUTIVE ENGINEER
UPPER PUNJARI DIVISION
HYDERABAD

BILL OF QUANTITIES (SAMPLE)

Bill No. 5 Tube wells and Pump-houses/Internal Electrification

Item	Description	Unit	Quantity	Rate		Amount
				Rupees in figures	Rupees in words	Rupees
1	2	3	4	5		6
501						
502						
503						
504						
505						
506						
Total for Bill No. 5 (Carried forward to Summary Page)						

BILL OF QUANTITIES (SAMPLE)

Bill No. 6 - Miscellaneous Items

Item	Description	Unit	Quantity	Rate		Amount
				Rupees in figures	Rupees in words	
1	2	3	4	5		6
601	Mobilization Cost					
602						
603						
604						
605						
606						
Total for Bill No. 6 Carried forward to Summary Page)						

BILL OF QUANTITIES (SAMPLE)

Bill No. 7		External Development				
Item	Description	Unit	Quantity	Rate		Amount
				Rupees in figures	Rupees in words	
1	2	3	4	5		6
601	Items of water supply & drainage					
602	Paths & parks					
603	External electrification					
604						
605						
606						
Total for Bill No. 7						
Carried forward to Summary Page)						

BILL OF QUANTITIES**C. Day work Schedule****General**

1. Reference is made to Sub-Clause 13.6 of the General Conditions of Contract. Work shall not be executed on a day work basis except by written order of the Engineer. Bidders shall enter basic rates for day work items in the Schedules, which rates shall apply to any quantity of day work ordered by the Engineer. Nominal quantities have been indicated against each item of day work, and the extended total for day work shall be carried forward to the bid price.

Day work Labour

2. In calculating payments due to the contractor for the execution of day work, the actual time of classes of labour directly doing the day work ordered by the Engineer and for which they are competent to perform will be measured excluding meal breaks and rest periods. The time of gangers (charge hands) actually doing work with the gang will also be measured but not the time of foreman or other supervisory personnel.
3. The contractor shall be entitled to payment in respect of the total time that labour is employed on day work, calculated at the basic rates entered by him in the Schedule of day work Rates for labour together with an additional percentage, payment on basic rates representing the contractor's profit, overheads, etc., as described below:
 - a) the basic rates for labour shall cover all direct costs to the contractor, including (but not limited to) the amount of wages paid to such labour, transportation time, overtime, subsistence allowances and any sums paid to or on behalf of such labour for social benefits in accordance with Pakistan law. The basic rates will be payable in local currency only; and
 - b) the additional percentage payment to be quoted by the bidder and applied to costs incurred under (a) above shall be deemed to cover the contractor's profit, overheads, superintendence, liabilities and insurances and allowances to labour timekeeping and clerical and office work; the use of consumable stores, water, lighting and power; the use and repair of staging's, scaffolding, workshops and stores, portable power tools, manual plant and tools; supervision by the contractor's staff, foremen and other supervisory personnel; and charges incidental to the foregoing.

SCHEDULE OF DAYWORK RATES

I. Labour

Item No.	Description	Unit	Nominal Quantity	Rate (Rs) in Figure	Rate (Rs) in Words	Extended Amount (Rs.)
1	2	3	4	5	6	7
D101	Ganger	Hr	500			
D102	Labourer	Hr	5,000			
D103	Brick layer	Hr	500			
D104	Mason	Hr	500			
D105	Carpenter	Hr	500			
D106	Steel work Erector	Hr	500			
	-----etc-----	Hr	500			
D113	Driver for vehicle up to 10 tons	Hr	1,000			
D114	Operator for excavator, dragline, shovel or crane	Hr	500			
D115	Operator for tractor, (tracked) with dozer blade or ripper	Hr	500			
E122	<p style="text-align: right;">Sub Total</p> <p>Allow _____ percent of subtotal for Contractor's overhead, profit, etc, in accordance with Paragraph 3(b) of Day work Schedule</p> <p>Total for Day work: Labour : _____</p> <p>(Carried forward to Day work Summary)</p>					

Appendix-D to Bid

Day work Material

4. The contractor shall be entitled to payment in respect of materials used for day work (except for materials for which the cost is included in the percentage addition to labour costs as detailed heretofore), at the basic rates entered by him in the Schedule of Day work Rates for materials together with an additional percentage payment on the basic rates to cover overhead charges and profit, as follows:
- a) the basic rates for materials shall be calculated on the basis of the invoiced price, freight, insurance, handling expenses, damage, losses, etc., and shall provide for delivery to store for stockpiling at the site. The basic rates shall be stated in local currency but payment will be made in the currency or currencies expended upon presentation of supporting documentation;
 - b) the additional percentage payment shall be quoted by the bidder and applied to the equivalent local currency payments made under Sub-Para(a) above; and
 - c) the cost of hauling materials used on work ordered to be carried out as Day work from the store or stockpile on the site to the place where it is to be used will be paid in accordance with the terms for Labour and Constructional Plant in this Schedule.

SCHEDULE OF DAYWORK RATES

II. Materials

Item No.	Description	Unit	Nominal Quantity	Rate (Rs) in Figure	Rate (Rs) in Words)	Extended Amount (Rs.)
1	2	3	4	5	6	7
D201	Cement, ordinary Portland or equivalent in bags	M: Ton	200			
D202	Mild Steel reinforcing bar up to 16mm diameter to BS 4449 or equivalent	M: Ton	100			
D203	Fine aggregate for concrete as specified in Clause _____	Cu: M	1,000			
D204	-----etc-----					
D222	Gelignite (Noble Special Gelatine 60 % or equivalent) including caps, fuse, wire and requisite accessories	M: Ton	10			
E223	<p style="text-align: right;">Sub Total</p> <p>Allow _____ percent of subtotal for Contractor's overhead, profit, etc., in accordance with Paragraph 4(b) of Day work Schedule</p> <p>Total for Day work: Materials _____</p> <p>(Carried forward to Day work Summary) _____</p>					

Appendix-D to Bid

Day Work Constructional Plant

5. The contractor shall be entitled to payments in respect of constructional plant already on site and employed on Day work at the basic rental rates entered by him in the Schedule of Day work Rates for constructional plant. The said rates shall be deemed to include complete allowance for depreciation, interest, indemnity and insurance, repairs, maintenance, supplies, fuel, lubricants, and other consumables, and all overhead, profit and administrative costs related to the use of such equipment. The cost of drivers, operators and assistants will be paid for separately as described under the section on Day work Labour.
6. In calculating the payment due to the Contractor for constructional plant employed on Day work, only the actual number of working hours will be eligible for payment, except that where applicable and agreed with the Engineer, the travelling time from the part of the site where the constructional plant was located when ordered by the Engineer to be employed on Day work and the time for return journey thereto shall be included for payment.
7. The basic rental rates for constructional plant employed on Day work shall be stated in Pakistani Rupees.

SCHEDULE OF DAYWORK RATES

III. Constructional Plant

Item No.	Description	Unit	Nominal Quantity	Rate (Rs.) in Figure	Rate Rs.) in Words	Extended Amount (Rs.)
1	2	3	4		5	6
D301	Excavator ,face shovel or dragline:					
	1. Up-to and including 1 Cu.M.	Hr	500			
	2. Over 1 Cu.M to 2 Cu. M.	Hr	400			
	3. Over 2 Cu. M	Hr	100			
D302	Tractor (tracked) including bull or angle dozer:					
	1. Up-to and including 150 HP	Hr	500			
	2. Over 150 to 200 HP	Hr	400			
	3. Over 200 to 250 HP	Hr	200			
D303	Tractor with ripper:					
	1. Up-to and including 200 HP	Hr	400			
	2. Over 200 to 250 HP	Hr	200			
D304	-----etc-----					
Total for day work: Constructional Plant (Carried forward to day work summary)						

DAYWORK**Summary (Day work)**

	Amount (Rs.)
(I) Total for day work: Labour	_____
(II) Total for day work: Materials	_____
(III) Total for day work: Constructional Plant	_____
<hr/>	
Total for day work (Carried forward to summary page of Bill of Quantities)	_____

BILL OF QUANTITIES (SAMPLE)**SUMMARY**

	Amount (Rs.)
Bill No. 1: Earthworks/Plinth and Foundation	
Bill No. 2: Culverts and Bridges/Ground Floor	
Bill No. 3: Subsurface Drains/Internal Water Supply & Sanitary Fittings	
Bill No 4: Subsurface Drains/ Pipe Laying and Man holes/Internal water Supply and Sanitary Fittings	
Bill No. 5 Tube wells and Pump-houses/Internal Electrification	
Bill No. 6 Miscellaneous Items	
Bill No. 7 External Development	
Sub-Total of Bills	_____
Day work	_____
Bid Price	_____

Note: All Provisional Sums are to be expended in whole or, in part at the direction and discretion of the Engineer in accordance with Sub-Clauses 52.4 and 58.2 of the General Conditions of Contract Part- I.

Appendix-E to Bid

PROPOSED CONSTRUCTION SCHEDULE

Pursuant to Sub-Clause 43.1 of the General Conditions of Contract, the works shall be completed on or before the date stated in Appendix-A to Bid. The bidder shall provide as Appendix-E to Bid, the Construction Schedule in the bar chart (CPM, PERT or any other to be specified herein) showing the sequence of work items and the period of time during which he proposes to complete each work item in such a manner that his proposed programme for completion of the whole of the works and parts of the works may meet procuring agency's completion targets in days noted below and counted from the date of receipt of Engineer's Notice to Commence (Attach sheets as required for the specified form of Construction Schedule):

<u>Description</u>	<u>Time for Completion</u>
1) Whole works	_____ days
2) Part-A	_____ days
3) Part-B	_____ days
4) _____	_____ days
5) _____	_____ days

METHOD OF PERFORMING THE WORK

[The bidder is required to submit a narrative outlining the method of performing the work. The narrative should indicate in detail and include but not be limited to:

1. Organization Chart indicating head office and field office personnel involved in management and supervision, engineering, equipment maintenance and purchasing.
2. Mobilization in Pakistan, the type of facilities including personnel accommodation, office accommodation, provision for maintenance and for storage, communications, security and other services to be used.
3. The method of executing the works, the procedures for installation of equipment and machinery and transportation of equipment and materials to the site.

LIST OF MAJOR EQUIPMENT – RELATED ITEMS

[The bidder will provide on Sheet 2 of this Appendix a list of all major equipment and related items, under separate heading for items owned, to be purchased or to be arranged on lease by him to carry out the works. The information shall include make, type, capacity, and anticipated period of utilization for all equipment which shall be in sufficient detail to demonstrate fully that the equipment will meet all requirements of the Specifications.]

LIST OF MAJOR EQUIPMENT (SAMPLE)

Owned Purchased or Leased	Description of Unit (Make, Model, Year)	Capacity HP Rating	Condition	Present Location or Source	Date of Delivery at Site	Period of Work on Project
1	2	3	4	5	6	7
e. Owned						
b. To be Purchased						
c. To be arranged on Lease						

CONSTRUCTION CAMP AND HOUSING FACILITIES

The Contractor in accordance with Clause 6 of the Conditions of Contract shall provide description of his construction camp's facilities and staff housing requirements.

The contractor shall be responsible for pumps, electrical power, water and electrical distribution systems, and sewerage system including all fittings, pipes and other items necessary for servicing the contractor's construction camp.

The bidder shall list or explain his plans for providing these facilities for the service of the contract as follows:

1. Site Preparation (clearing, land preparation, etc.).
2. Provision of Services.
 - a) Power (expected power load, etc.).
 - b) Water (required amount and system proposed).
 - c) Sanitation (sewage disposal system, etc.).
3. Construction of Facilities
 - a) Contractor's Office, Workshop and Work Areas (areas required and proposed layout, type of construction of buildings, etc.).
 - b) Warehouses and Storage Areas (area required, type of construction and layout).
 - c) Housing and Staff Facilities (Plans for housing for proposed staff, layout, type of construction, etc.).
4. Construction Equipment Assembly and Preparation (detailed plans for carrying out this activity).
5. Other Items Proposed (Security services, etc.).

Appendix-I to Bid

LIST OF SUBCONTRACTORS

We intend to subcontract the following parts of the work to subcontractors. In my/our opinion, the subcontractors named hereunder are reliable and competent to perform that part of the work for which each is listed.

Enclosed are documentation outlining experience of subcontractors, the curriculum vitae and experience of their key personnel who will be assigned to the contract, equipment to be supplied by them, size, location and type of contracts carried out in the past.

Part of Works (Give Details)	Subcontractor (With Complete Address)
1	2

ESTIMATED PROGRESS PAYMENTS (SAMPLE)

Bidder's estimate of the value of work which would be executed by him during each of the periods stated below, based on his Programme of the works and the Rates in the Bill of Quantities, expressed in Pakistani Rupees:

Quarter/ Year/ Period	Amounts (in thousands)
1	2
1st Quarter	
2 nd Quarter	
3 rd Quarter	
4 th Quarter	
5 th Quarter	
6 th Quarter	
7 th Quarter	
8 th Quarter	
9 th Quarter	
Bid Price	

**ORGANIZATION CHART
FOR THE
SUPERVISORY STAFF AND LABOUR**

(To be filled in by the bidder)

(INTEGRITY PACT)

DECLARATION OF FEES, COMMISSION AND BROKERAGE ETC; PAYABLE BY CONTRACTORS.

(FOR CONTRACTS WORTH RS. 10.00 MILLION OR MORE)

Contract No. _____ Dated _____
Contract Value: _____
Contract Title: _____

..... [name of Contractor] hereby declares that it has not obtained or induced the procurement of any contract, right, interest, privilege or other obligation or benefit from Government of Sindh (GoS) or any administrative subdivision or agency thereof or any other entity owned or controlled by it (GoS) through any corrupt business practice.

Without limiting the generality of the foregoing, [name of Contractor] represents and warrants that it has fully declared the brokerage, commission, fees etc. paid or payable to anyone and not given or agreed to give and shall not give or agree to give to anyone within or outside Pakistan either directly or indirectly through any natural or juridical person, including its affiliate, agent, associate, broker, consultant, director, promoter, shareholder, sponsor or subsidiary, any commission, gratification, bribe, finder's fee or kickback, whether described as consultation fee or otherwise, with the object of obtaining or inducing the procurement of a contract, right, interest, privilege or other obligation or benefit in whatsoever form from, from Procuring Agency (PA) except that which has been expressly declared pursuant hereto.

[name of Contractor] accepts full responsibility and strict liability that it has made and will make full disclosure of all agreements and arrangements with all persons in respect of or related to the transaction with PA and has not taken any action or will not take any action to circumvent the above declaration, representation or warranty.

[name of Contractor] accepts full responsibility and strict liability for making any false declaration, not making full disclosure, misrepresenting facts or taking any action likely to defeat the purpose of this declaration, representation and warranty. It agrees that any contract, right, interest, privilege or other obligation or benefit obtained or procured as aforesaid shall, without prejudice to any other rights and remedies available to PA under any law, contract or other instrument, be voidable at the option of PA.

Notwithstanding any rights and remedies exercised by PA in this regard, [name of Supplier/Contractor/Consultant] agrees to indemnify PA for any loss or damage incurred by it on account of its corrupt business practices and further pay compensation to PA in an amount equivalent to ten times the sum of any commission, gratification, bribe, finder's fee or kickback given by [name of Contractor] as aforesaid for the purpose of obtaining or inducing the procurement of any contract, right, interest, privilege or other obligation or benefit in whatsoever form from PA.

.....
[Procuring Agency]

[Contractor]

FORMS

**BID SECURITY
PERFORMANCE SECURITY
CONTRACT AGREEMENT
MOBILIZATION ADVANCE GUARANTEE
INDENTURE BOND FOR SECURED ADVANCE**

BID SECURITY
(Bank Guarantee)

Security Executed on _____
(Date)

Name of Surety (Bank) with Address: _____
(Scheduled Bank in Pakistan)

Name of Principal (Bidder) with Address _____

Penal Sum of Security Rupees. _____ (Rs. _____)

Bid Reference No. _____

KNOW ALL MEN BY THESE PRESENTS, that in pursuance of the terms of the bid and at the request of the said Principal (Bidder) we, the Surety above named, are held and firmly bound unto _____

(hereinafter called the 'Procuring Agency') in the sum stated above for the payment of which sum well and truly to be made, we bind ourselves, our heirs, executors, administrators and successors, jointly and severally, firmly by these presents.

THE CONDITION OF THIS OBLIGATION IS SUCH, that whereas the Bidder has submitted the accompanying bid dated _____ for Bid No. _____ for _____ (Particulars of Bid) to the said Procuring Agency; and

WHEREAS, the Procuring Agency has required as a condition for considering said bid that the bidder furnishes a bid security in the above said sum from a Scheduled Bank in Pakistan or from a foreign bank duly counter-guaranteed by a Scheduled Bank in Pakistan, to the procuring agency, conditioned as under:

- (1) that the bid security shall remain in force up to and including the date 28 days after the deadline for validity of bids as stated in the Instructions to bidders or as it may be extended by the procuring agency, notice of which extension(s) to the Surety is hereby waived;
- (2) that the bid security of unsuccessful bidders will be returned by the procuring agency after expiry of its validity or upon signing of the Contract Agreement; and
- (3) that in the event of failure of the successful bidder to execute the proposed Contract Agreement for such work and furnish the required Performance Security, the entire said sum be paid immediately to the said procuring agency pursuant to Clause 15.6 of the Instruction to bidders for the successful bidder's failure to perform.

NOW THEREFORE, if the successful bidder shall, within the period specified therefore, on the prescribed form presented to him for signature enter into a formal Contract with the said procuring agency in accordance with his bid as accepted and furnish within twenty eight (28) days of his being requested to do so, a Performance Security with good and sufficient surety, as may be required, upon the form prescribed by the said procuring agency for the faithful performance and proper fulfilment of the said Contract or in the event of non-withdrawal of the said bid within the time specified for its validity then this obligation shall be void and of no effect, but otherwise to remain in full force and effect.

PROVIDED THAT the Surety shall forthwith pay the procuring agency, the said sum upon first written demand of the procuring agency (without cavil or argument) and without requiring the procuring agency to prove or to show grounds or reasons for such demand,

**FORM OF PERFORMANCE SECURITY
(Bank Guarantee)**

Guarantee No. _____
 Executed on _____
 Expiry date _____

[Letter by the Guarantor to the Procuring Agency]

Name of Guarantor (Bank) with address: _____
 (Scheduled Bank in Pakistan)

Name of Principal (Contractor) with address: _____

Penal Sum of Security (express in words and figures) _____

Letter of Acceptance No. _____ Dated _____

KNOW ALL MEN BY THESE PRESENTS, that in pursuance of the terms of the bidding documents and above said Letter of Acceptance (hereinafter called the Documents) and at the request of the said Principal we, the Guarantor above named, are held and firmly bound unto the _____ (hereinafter called the procuring agency) in the penal sum of the amount stated above for the payment of which sum well and truly to be made to the said procuring agency, we bind ourselves, our heirs, executors, administrators and successors, jointly and severally, firmly by these presents.

THE CONDITION OF THIS OBLIGATION IS SUCH, that whereas the Principal has accepted the procuring agency's above said Letter of Acceptance for _____ (Name of Contract) for the _____ (Name of Project).

NOW THEREFORE, if the Principal (Contractor) shall well and truly perform and fulfill all the undertakings, covenants, terms and conditions of the said Documents during the original terms of the said Documents and any extensions thereof that may be granted by the procuring agency, with or without notice to the Guarantor, which notice is, hereby, waived and shall also well and truly perform and fulfill all the undertakings, covenants terms and conditions of the Contract and of any and all modifications of said Documents that may hereafter be made, notice of which modifications to the Guarantor being hereby waived, then, this obligation to be void; otherwise to remain in full force and virtue till all requirements of Clause 49, Defects Liability, of Conditions of Contract are fulfilled.

Our total liability under this Guarantee is limited to the sum stated above and it is a condition of any liability attaching to us under this Guarantee that the claim for payment in writing shall be received by us within the validity period of this Guarantee, failing which we shall be discharged of our liability, if any, under this Guarantee.

We, _____ (the Guarantor), waiving all objections and defenses under the Contract, do hereby irrevocably and independently guarantee to pay to the procuring agency without delay upon the procuring agency's first written demand without

civil or arguments and without requiring the procuring agency to prove or to show grounds or reasons for such demand any sum or sums up to the amount stated above, against the procuring agency's written declaration that the Principal has refused or failed to perform the obligations under the Contract which payment will be effected by the Guarantor to Procuring Agency's designated Bank & Account Number.

PROVIDED ALSO THAT the procuring agency shall be the sole and final judge for deciding whether the Principal (Contractor) has duly performed his obligations under the Contract or has defaulted in fulfilling said obligations and the Guarantor shall pay without objection any sum or sums up to the amount stated above upon first written demand from the procuring agency for with and without any reference to the Principal or any other person.

IN WITNESS WHEREOF, the above-bounden Guarantor has executed this Instrument under its seal on the date indicated above, the name and corporate seal of the Guarantor being hereto affixed and these presents duly signed by its undersigned representative, pursuant to authority of its governing body.

Witness:

1. _____

Corporate Secretary (Seal)

2. _____

Name, Title & Address

Guarantor (Bank)

Signature _____

Name _____

Title _____

Corporate Guarantor (Seal)

FORM OF CONTRACT AGREEMENT

THIS CONTRACT AGREEMENT (hereinafter called the "Agreement") made on the _____ day of _____ (month) 20____ between

(hereafter called the "Procuring Agency") of the one part and _____ (hereafter called the "Contractor") of the other part.

WHEREAS the Procuring Agency is desirous that certain works, viz _____ should be executed by the Contractor and has accepted a bid by the Contractor for the execution and completion of such works and the remedying of any defects therein.

NOW this Agreement witnesseth-- as follows:

1. In this Agreement words and expressions shall have the same meanings as are respectively assigned to them in the Conditions of Contract hereinafter referred to.
2. The following documents after incorporating addenda, if any, except those parts relating to instructions to bidders shall be deemed to form and be read and construed as part of this Agreement, viz:
 - (a) The Contract Agreement;
 - (b) The Letter of Acceptance;
 - (c) The completed Form of Bid;
 - (d) Special Stipulations (Appendix-A to Bid);
 - (e) The Special Conditions of Contract – Part II;
 - (f) The General Conditions – Part I;
 - (g) The priced Bill of Quantities (Appendix-D to Bid);
 - (h) The completed Appendices to Bid (B, C, E to L);
 - (i) The Drawings;
 - (j) The Specifications.
 - (k) _____ (any other)
3. In consideration of the payments to be made by the procuring agency to the Contractor as hereinafter mentioned, the Contractor hereby covenants with the procuring agency to execute and complete the works and remedy defects therein in conformity and in all respects with the provisions of the contract.
4. Procuring agency hereby covenants to pay the contractor, in consideration of the execution and completion of the works as per provisions of the contract, the contract Price or such other sum as may become payable under the provisions of the contract at the times and in the manner prescribed by the contract.

IN WITNESS WHEREOF the parties hereto have caused this Agreement to be executed on the day, month and year first before written in accordance with their respective laws.

Signature of the Contactor

Signature of Procuring Agency

(Seal)

(Seal)

Signed, Sealed and Delivered in the presence of:

Witness:

Witness:

(Name, Title and Address)

(Name, Title and Address)

GUARANTOR

1. **Signature** _____
2. **Name** _____
3. **Title** _____

WITNESS

1. _____

Corporate Secretary (Seal)
2. _____

(Name Title & Address)

Corporate Guarantor (Seal)

INDENTURE FOR SECURED ADVANCES.

(For use in cases in which is contract is for finished work and the contractor has entered into an agreement for the execution of a certain specified quantity of work in a given time).

This INDENTURE made the day of
..... 20..... BETWEEN (hereinafter called "the Contractor" which expression shall where the context so admits or implied be deemed to include his heirs, executors, administrators and assigns) of the one part and THE GOVERNOR OF SINDH (hereinafter called "the Government" of the other part).

WHEREAS by an agreement, dated (hereinafter called the said agreement, the contractor has agreed to perform the under-mentioned works (hereinafter referred to as the said work):-

(Here enter (the description of the works).¹

AND WHEREAS the contractor has applied to the
.....for an advance to him of Rupees
(Rs.) on the security of materials absolutely belonging to him and brought by him to the site of the said works the subject of the said agreement for use in the construction of such of the said works as he has undertaken to execute at rates fixed for the finished work (inclusive of the cost of materials and labour and other charge) AND WHEREAS the Government has agreed to advance to the Contractor the sum of Rupees, (Rs.) on the security of materials the quantities and other particulars of which are detailed in Part II of Running Account Bill (B), the said works signed by the contractor

Fin R. Form. 17.A

On and on such covenants and conditions as are hereinafter contained and the Government has reserved to itself the option of marking any further advance or advances on the security of other materials brought by the Contractor to the site of the said works.

NOW THIS INDENTURE WTTNESSETH that in pursuance of the said agreement and in consideration of the sum of Rupees,
(Rs.) on or before the execution of these presents paid to the Contractor by the Government (the receipt whereof the Contractor doth hereby acknowledge) and of such further advances (if any) as may be made to him as aforesaid (all of which advances are hereinafter collectively referred to as the said amount) the Contractor doth hereby assign unto the Government the said materials by way of security for the said amount

And doth hereby covenant and agree with the Government and declare ay follow :-

(1) That the said sum of Rupees, RS.
.....) so advanced by the Government to the Contractor as aforesaid and all or any further sum or sums which may be advanced as aforesaid shall be employed by the contractor in or towards expending the execution of the said works and for no other purpose whatsoever.

(2) That the materials detailed in the said Running Account Bill (B) which have been offered to and accepted by (he Government as security for the said amount are

absolutely by the Contractors own property free from encumbrances of any kind and the Contractor will not make any application for or receive a further advance on the security of materials which are not absolutely his own property and free from encumbrances of any kind and the contractor hereby agrees, at all times, to indemnify and save harmless the Government against all claims whatsoever to any materials in respect of which an advance has been made to him as aforesaid.

(3) That the said materials detailed in the said Running Account Bill (B) and all other materials on the security of which any further advance or advances may hereafter be made as aforesaid (hereinafter called the said materials) shall be used by the Contractor solely in the execution of the said works in accordance with the directions of the Divisional Officer (hereinafter called the Divisional Officer) and in the terms of the said agreement.

(4) That the Contractor shall make at his own cost all necessary and adequate arrangement for the proper watch, safe custody and protection against all risks of the said material and that until used in construction as aforesaid the said materials shall remain at the site of the said works in the Contractor's custody and at his own risk and on his own responsibility and shall at all times be open to inspection by the Divisional Officer or any officer authorized by him. In the event of the said materials of any part (hereof being stolen, destroyed or damaged or becoming deteriorated in a greater degree than is due to reasonable use and wear thereof Contractor will forthwith replace the same with other materials of like quality or repair and make good the same as required by the Divisional Officer and the materials so brought to replace the said materials so repaired and made good shall also be considered as security for the said amount.

(5) That the said materials shall not on any account be removed from the site of the said works except with the written permission of the Divisional Officer or an officer authorized by him in that behalf

(6) That the said amount shall be payable in full when or before the Contractor receives payment, from the Government of the price payable to him for the said works under the terms and provisions of the said agreement PROVIDED THAT if any intermediate payments are made to the contractor on account of work done then on the occasion of each such payment the Government will be at liberty to make a recovery from the Contractors Bill for such payment by deducting therefrom in the value of the said materials (then actually used in the construction and in respect of which recovery has not been made previously the value for this purpose being determined in respect of each description of material at the rates at which the amount of the advances made under these presents were calculated.

(7) That if the Contractor shall at any time make any default in the performance or observation in any respect of any of the terms and provisions of the said agreement or of these presents the total amount of the advance or advances that may still be owing to the Government shall immediately on the happening of such default be repayable by the Contractor to the Government together with interest thereon at twelve percent per annum from the date or respective dates of such advance or advances to the date of repayment and with all costs, charges, damages and expenses incurred by the Government in or for the recovery thereof or the

enforcement of this security or otherwise by reason of (he default of the Contractor and any moneys so becoming due and payable shall constitute a debt due from the Contractor to the Government and the Contractor hereby covenants and agrees with the Government to repay and the same respectively to it accordingly.

(8) That the Contractor hereby charges all the said materials with the repayment to the Government of the said sum of Rupees.....

(Rs.) and any further sum or sums which may be advanced as aforesaid and all costs charges damages and expenses payable under these present PROVIDED ALWAYS and it is hereby agreed and declared that not, withstanding anything in the said agreement and without prejudice to the powers contained therein if and whether the covenant for payment and repayment hereinbefore contained shall become enforceable and the money owing shall not be paid to accordingly.

Once there with the Government may at any time thereafter adopt all or any of following courses as it may deem best ;-

(a) Seize and utilize the said materials or any part thereof in the completion of the said works on behalf of the Contractor in accordance with the provisions in that behalf contained in the said agreement debiting the Contractor with the actual cost of effecting such completion the amount due in respect of advances under these presents and crediting the Contractor with the value of work done as he had carried it out in accordance with the said agreement and at the rates thereby provided. If the balance is against the Contractor he is to pay the same to the Government on demand.

(b) Remove and sell by public auction the seized materials or any part thereof and out of the moneys arising from the sale retain all the sums aforesaid repayable to the Government under these presents and pay over the surplus (if any) to the Contractor.

(c) Deduct all or any part of the moneys owing out of the security deposit or any sum due to the Contractor under the said agreement.

(9) That except as is expressly provided by the presents interest on the said advance shall not be payable.

(10) That in the event of any conflict between the provisions of these presents and the said agreement the provisions of these presents shall prevail and in the event of any dispute or difference arising over the construction or effect of these presents the settlement of which has not been hereinbefore expressly provided for the same shall be referred to the Superintending Engineer/Executive District Officer/Officer one grade higher to officer signed the agreement Circle whose..... decision shall be final and the provisions of the Arbitration Act 1940 for the time being in force so far as they are applicable shall apply to any such reference.

Singed, sealed and delivered by*

In the presence of

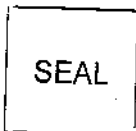

1st witness
2nd witness

Signed, sealed and delivered by*
In the presence of

SEAL

1st witness
2nd witness

Notes on the Conditions of Contract

The Conditions of Contract comprise two parts:

- (a) **Part I - General Conditions of Contract**
- (b) **Part II - Special Conditions of Contract**

Over the years, a number of "model" General Conditions of Contract have evolved. The one used in these Standard Bidding Documents was prepared by the International Federation of Consulting Engineers (Federation Internationale des Ingenieurs-Conseils, or FIDIC), and is commonly known as the FIDIC Conditions of Contract. (The used version is the harmonized Edition March 2006).

The FIDIC Conditions of Contract have been prepared for an ad measurement (unit price or unit rate) type of contract, and cannot be used without major modifications for other types of contract, such as lump sum, turnkey, or target cost contracts.

The standard text of the General Conditions of Contract chosen must be retained intact to facilitate its reading and interpretation by bidders and its review by the procuring agency. Any amendments and additions to the General Conditions, specific to the contract in hand, should be introduced in the Particular Conditions of Contract.

The use of standard conditions of contract for all civil works will ensure comprehensiveness of coverage, better balance of rights or obligations between procuring agency and Contractor, general acceptability of its provisions, and savings in time and cost for bid preparation and review, leading to more economic prices.

The FIDIC Conditions of Contract are copyrighted and may not be copied, faxed, or reproduced. Without taking any responsibility of its being accurate, Pakistan Engineering Council with prior consent of FIDIC Secretariat, has reproduced herein the FIDIC General Conditions of Contract for reference purpose only which cannot be used by the users for preparing their bidding documents. The bidding document may include a purchased copy, the cost of which can be retrieved as part of the selling price of the bidding document. Alternatively, the FIDIC Conditions of Contract can be referred to in the bidding documents, and the bidders are advised to obtain copies directly from FIDIC.*

* Add the following text if the bidding documents, as issued, do not include a copy:

"Copies of the FIDIC Conditions of Contract can be obtained from:

To request such permission please contact:

FIDIC CASE POSTALE, CH-1215 Switzerland;

Tel. +41 22 799 49 00;

Fax; +41 22 799 49 01

E-mail: fidic@fidic.org.

Conditions of Contract for CONSTRUCTION

FOR BUILDING AND ENGINEERING
WORKS DESIGNED BY THE EMPLOYER

Multilateral Development Bank Harmonised Edition
March 2006

General Conditions

This publication is exclusive for use as provided under a Licence Agreement between a Participating Bank and FIDIC, and, consequently, no part of this publication may be reproduced, translated, adapted, stored in a retrieval system or communicated, in any form or by any means, whether mechanical, electronic, magnetic, photocopying, recording or otherwise, without prior permission in writing from FIDIC. To request such permission, please contact: FIDIC, Case Postale 311, CH-1215 Geneva 15, Switzerland; Tel. +41 22 799 49 00; Fax +41 22 799 49 01; E-mail: fidic@fidic.org. FIDIC is not responsible for the accuracy or completeness of translations of this publication unless such translation explicitly indicates otherwise.

FEDERATION INTERNATIONALE DES INGENIEURS-CONSEILS
INTERNATIONAL FEDERATION OF CONSULTING ENGINEERS
INTERNATIONALE VEREINIGUNG BERATENDER INGENIEURE
FEDERACION INTERNACIONAL DE INGENIEROS CONSULTORES



General Conditions

CONTENTS

Definitions listed alphabetically

GENERAL PROVISIONS

- 1.1 Definitions
- 1.2 Interpretation
- 1.3 Communications
- 1.4 Law and Language
- 1.5 Priority of Documents
- 1.6 Contract Agreement
- 1.7 Assignment
- 1.8 Care and Supply of Documents
- 1.9 Delayed Drawings or Instructions
- 1.10 Employer's Use of Contractor's Documents
- 1.11 Contractor's Use of Employer's Documents
- 1.12 Confidential Details
- 1.13 Compliance with Laws
- 1.14 Joint and Several Liability
- 1.15 Inspections and Audit by the Bank

2 THE EMPLOYER

- 2.1 Right of Access to the Site
- 2.2 Permits, Licences or Approvals
- 2.3 Employer's Personnel
- 2.4 Employer's Financial Arrangements
- 2.5 Employer's Claims

3 THE ENGINEER

- 3.1 Engineer's Duties and Authority
- 3.2 Delegation by the Engineer
- 3.3 Instructions of the Engineer
- 3.4 Replacement of the Engineer
- 3.5 Determinations

4 THE CONTRACTOR

- 4.1 Contractor's General Obligations
- 4.2 Performance Security

- 4.3 Contractor's Representative
- 4.4 Subcontractors
- 4.5 Assignment of Benefit of Subcontract
- 4.6 Co-operation
- 4.7 Setting Out
- 4.8 Safety Procedures
- 4.9 Quality Assurance
- 4.10 Site Data
- 4.11 Sufficiency of the Accepted Contract Amount
- 4.12 Unforeseeable Physical Conditions
- 4.13 Rights of Way and Facilities
- 4.14 Avoidance of Interference
- 4.15 Access Route
- 4.16 Transport of Goods
- 4.17 Contractor's Equipment
- 4.18 Protection of the Environment
- 4.19 Electricity, Water and Gas
- 4.20 Employer's Equipment and Free-Issue Materials
- 4.21 Progress Reports
- 4.22 Security of the Site
- 4.23 Contractor's Operations on Site
- 4.24 Fossils

- 5 NOMINATED SUBCONTRACTORS

- 5.1 Definition of "nominated Subcontractor"
- 5.2 Objection to Nomination
- 5.3 Payments to nominated Subcontractors
- 5.4 Evidence of Payments

- 6 STAFF AND LABOUR

- 6.1 Engagement of Staff and Labour
- 6.2 Rates of Wages and Conditions of Labour
- 6.3 Persons in the Service of Employer
- 6.4 Labour Laws
- 6.5 Working Hours
- 6.6 Facilities for Staff and Labour
- 6.7 Health and Safety
- 6.8 Contractor's Superintendence
- 6.9 Contractor's Personnel
- 6.10 Records of Contractor's Personnel and Equipment
- 6.11 Disorderly Conduct
- 6.12 Foreign Personnel
- 6.13 Supply of Foodstuffs
- 6.14 Supply of Water
- 6.15 Measures against Insect and Pest Nuisance
- 6.16 Alcoholic Liquor or Drugs
- 6.17 Arms and Ammunition
- 6.18 Festival and Religious Customs
- 6.19 Funeral Arrangements
- 6.20 Prohibition of Forced or Compulsory Labour
- 6.21 Prohibition of Harmful Child Labour
- 6.22 Employment Records of Workers

7 PLANT, MATERIALS AND WORKMANSHIP

- 7.1 Manner of Execution
- 7.2 Samples
- 7.3 Inspection
- 7.4 Testing
- 7.5 Rejection
- 7.6 Remedial Work
- 7.7 Ownership of Plant and Materials
- 7.8 Royalties

8 COMMENCEMENT, DELAYS AND SUSPENSION

- 8.1 Commencement of Works
- 8.2 Time for Completion
- 8.3 Programme
- 8.4 Extension of Time for Completion
- 8.5 Delays Caused by Authorities
- 8.6 Rate of Progress
- 8.7 Delay Damages
- 8.8 Suspension of Work
- 8.9 Consequences of Suspension
- 8.10 Payment for Plant and Materials in Event of Suspension
- 8.11 Prolonged Suspension
- 8.12 Resumption of Work

9 TESTS ON COMPLETION

- 9.1 Contractor's Obligations
- 9.2 Delayed Tests
- 9.3 Retesting
- 9.4 Failure to Pass Tests on Completion

10 EMPLOYER'S TAKING OVER

- 10.1 Taking Over of the Works and Sections
- 10.2 Taking Over of Parts of the Works
- 10.3 Interference with Tests on Completion
- 10.4 Surfaces Requiring Reinstatement

11 DEFECTS LIABILITY

- 11.1 Completion of Outstanding Work and Remedying Defects
- 11.2 Cost of Remedying Defects
- 11.3 Extension of Defects Notification Period
- 11.4 Failure to Remedy Defects
- 11.5 Removal of Defective Work
- 11.6 Further Tests
- 11.7 Right of Access
- 11.8 Contractor to Search
- 11.9 Performance Certificate
- 11.10 Unfulfilled Obligations
- 11.11 Clearance of Site

- 12 MEASUREMENT AND EVALUATION
 - 12.1 Works to be Measured
 - 12.2 Method of Measurement
 - 12.3 Evaluation
 - 12.4 Omissions
- 13 VARIATIONS AND ADJUSTMENTS
 - 13.1 Right to Vary
 - 13.2 Value Engineering
 - 13.3 Variation Procedure
 - 13.4 Payment in Applicable Currencies
 - 13.5 Provisional Sums
 - 13.6 Daywork
 - 13.7 Adjustments for Changes in Legislation
 - 13.8 Adjustments for Changes in Cost
- 14 CONTRACT PRICE AND PAYMENT
 - 14.1 The Contract Price
 - 14.2 Advance Payment
 - 14.3 Application for Interim Payment Certificates
 - 14.4 Schedule of Payments
 - 14.5 Plant and Materials intended for the Works
 - 14.6 Issue of Interim Payment Certificates
 - 14.7 Payment
 - 14.8 Delayed Payment
 - 14.9 Payment of Retention Money
 - 14.10 Statement at Completion
 - 14.11 Application for Final Payment Certificate
 - 14.12 Discharge
 - 14.13 Issue of Final Payment Certificate
 - 14.14 Cessation of Employer's Liability
 - 14.15 Currencies of Payment
- 15 TERMINATION BY EMPLOYER
 - 15.1 Notice to Correct
 - 15.2 Termination by Employer
 - 15.3 Valuation at Date of Termination
 - 15.4 Payment after Termination
 - 15.5 Employer's Entitlement to Termination for Convenience
 - 15.6 Corrupt or Fraudulent Practices
- 16 SUSPENSION AND TERMINATION BY CONTRACTOR
 - 16.1 Contractor's Entitlement to Suspend Work
 - 16.2 Termination by Contractor
 - 16.3 Cessation of Work and Removal of Contractor's Equipment
 - 16.4 Payment on Termination
- 17 RISK AND RESPONSIBILITY
 - 17.1 Indemnities
 - 17.2 Contractor's Care of the Works

- 17.3 Employer's Risks
- 17.4 Consequences of Employer's Risks
- 17.5 Intellectual and Industrial Property Rights
- 17.6 Limitation of Liability
- 17.7 Use of Employer's Accommodation/Facilities

18 INSURANCE

- 18.1 General Requirements for Insurances
- 18.2 Insurance for Works and Contractor's Equipment
- 18.3 Insurance against Injury to Persons and Damage to Property
- 18.4 Insurance for Contractor's Personnel

19 FORCE MAJEURE

- 19.1 Definition of Force Majeure
- 19.2 Notice of Force Majeure
- 19.3 Duty to Minimise Delay
- 19.4 Consequences of Force Majeure
- 19.5 Force Majeure Affecting Subcontractor
- 19.6 Optional Termination, Payment and Release
- 19.7 Release from Performance

20 CLAIMS, DISPUTES AND ARBITRATION

- 20.1 Contractor's Claims
- 20.2 Appointment of the Dispute Board
- 20.3 Failure to Agree on the Composition of the Dispute Board
- 20.4 Obtaining Dispute Board's Decision
- 20.5 Amicable Settlement
- 20.6 Arbitration
- 20.7 Failure to Comply with Dispute Board's Decision
- 20.8 Expiry of Dispute Board's Appointment

APPENDIX: DISPUTE BOARD

General Conditions of Dispute Board Agreement
Annex: Procedural Rules

INDEX OF SUB-CLAUSES

77

Definitions listed alphabetically

1.1.4.1	Accepted Contract Amount	1.1.4.7	Interim Payment Certificate
1.1.2.11	Bank	1.1.6.5	Laws
1.1.3.1	Base Date	1.1.1.3	Letter of Acceptance
1.1.1.9	Bill of Quantities	1.1.1.4	Letter of Tender
1.1.2.12	Borrower	1.1.4.8	Local Currency
1.1.3.2	Commencement Date	1.1.5.3	Materials
1.1.1.1	Contract	1.1.2.1	Party
1.1.1.2	Contract Agreement	1.1.4.9	Payment Certificate
1.1.1.10	Contract Data	1.1.3.8	Performance Certificate
1.1.4.2	Contract Price	1.1.6.6	Performance Security
1.1.2.3	Contractor	1.1.5.4	Permanent Works
1.1.6.1	Contractor's Documents	1.1.5.5	Plant
1.1.5.1	Contractor's Equipment	1.1.4.10	Provisional Sum
1.1.2.7	Contractor's Personnel	1.1.4.11	Retention Money
1.1.2.5	Contractor's Representative	1.1.1.7	Schedules
1.1.4.3	Cost	1.1.1.9	Schedule, Payment Currencies
1.1.6.2	Country	1.1.5.6	Section
1.1.2.9	DB	1.1.6.7	Site
1.1.3.9	day	1.1.1.5	Specification
1.1.1.9	Daywork Schedule	1.1.4.12	Statement
1.1.3.7	Defects Notification Period	1.1.2.8	Subcontractor
1.1.1.6	Drawings	1.1.3.5	Taking-Over Certificate
1.1.2.2	Employer	1.1.5.7	Temporary Works
1.1.6.3	Employer's Equipment	1.1.1.8	Tender
1.1.2.6	Employer's Personnel	1.1.3.6	Tests after Completion
1.1.2.4	Engineer	1.1.3.4	Tests on Completion
1.1.2.10	FIDIC	1.1.3.3	Time for Completion
1.1.4.4	Final Payment Certificate	1.1.6.8	Unforeseeable
1.1.4.5	Final Statement	1.1.6.9	Variation
1.1.6.4	Force Majeure	1.1.5.8	Works
1.1.4.6	Foreign Currency	1.1.3.9	year
1.1.5.2	Goods		

General Conditions

General Provisions

1.1

Definitions

In the Conditions of Contract ("these Conditions"), which include Particular Conditions, Parts A and B, and these General Conditions, the following words and expressions shall have the meanings stated. Words indicating persons or parties include corporations and other legal entities, except where the context requires otherwise.

1.1.1

The Contract

1.1.1.1 "Contract" means the Contract Agreement, the Letter of Acceptance, the Letter of Tender, these Conditions, the Specification, the Drawings, the Schedules, and the further documents (if any) which are listed in the Contract Agreement or in the Letter of Acceptance.

1.1.1.2 "Contract Agreement" means the contract agreement referred to in Sub-Clause 1.6 [Contract Agreement].

1.1.1.3 "Letter of Acceptance" means the letter of formal acceptance, signed by the Employer, of the Letter of Tender, including any annexed memoranda comprising agreements between and signed by both Parties. If there is no such letter of acceptance, the expression "Letter of Acceptance" means the Contract Agreement and the date of issuing or receiving the Letter of Acceptance means the date of signing the Contract Agreement.

1.1.1.4 "Letter of Tender" means the document entitled letter of tender or letter of bid, which was completed by the Contractor, and includes the signed offer to the Employer for the Works.

1.1.1.5 "Specification" means the document entitled specification, as included in the Contract, and any additions and modifications to the specification in accordance with the Contract. Such document specifies the Works.

1.1.1.6 "Drawings" means the drawings of the Works, as included in the Contract, and any additional and modified drawings issued by (or on behalf of) the Employer in accordance with the Contract.

1.1.1.7 "Schedules" means the document(s) entitled schedules, completed by the Contractor and submitted with the Letter of Tender, as included in the Contract. Such document may include the Bill of Quantities, data, lists, and schedules of rates and/or prices.

1.1.1.8 "Tender" means the Letter of Tender and all other documents which the Contractor submitted with the Letter of Tender, as included in the Contract.

1.1.1.9 "Bill of Quantities", "Daywork Schedule" and "Schedule of Payment Currencies" mean the documents so named (if any) which are comprised in the Schedules.

1.1.1.10 "Contract Data" means the pages completed by the Employer entitled contract data which constitute Part A of the Particular Conditions.

1.1.2

Parties and Persons

1.1.2.1 "Party" means the Employer or the Contractor, as the context requires.

1.1.2.2 "Employer" means the person named as employer in the Contract Data and the legal successors in title to this person.

1.1.2.3 "Contractor" means the person(s) named as contractor in the Letter of Tender accepted by the Employer and the legal successors in title to this person(s).

1.1.2.4 "Engineer" means the person appointed by the Employer to act as the Engineer for the purposes of the Contract and named in the Contract Data, or other person appointed from time to time by the Employer and notified to the Contractor under Sub-Clause 3.4 [Replacement of the Engineer].

1.1.2.5 "Contractor's Representative" means the person named by the Contractor in the Contract or appointed from time to time by the Contractor under Sub-Clause 4.3 [Contractor's Representative], who acts on behalf of the Contractor.

1.1.2.6 "Employer's Personnel" means the Engineer, the assistants referred to in Sub-Clause 3.2 [Delegation by the Engineer] and all other staff, labour and other employees of the Engineer and of the Employer; and any other personnel notified to the Contractor, by the Employer or the Engineer, as Employer's Personnel.

1.1.2.7 "Contractor's Personnel" means the Contractor's Representative and all personnel whom the Contractor utilises on Site, who may include the staff, labour and other employees of the Contractor and of each Subcontractor; and any other personnel assisting the Contractor in the execution of the Works.

1.1.2.8 "Subcontractor" means any person named in the Contract as a subcontractor, or any person appointed as a subcontractor, for a part of the Works; and the legal successors in title to each of these persons.

1.1.2.9 "DB" means the person or three persons appointed under Sub-Clause 20.2 [Appointment of the Dispute Board] or Sub-Clause 20.3 [Failure to Agree on the Composition of the Dispute Board].

1.1.2.10 "FIDIC" means the Fédération Internationale des Ingénieurs-Conseils, the international federation of consulting engineers.

1.1.2.11 "Bank" means the financing institution (if any) named in the Contract Data.

1.1.2.12 "Borrower" means the person (if any) named as the borrower in the Contract Data.

1.1.3

Dates, Tests, Periods
and Completion

1.1.3.1 "Base Date" means the date 28 days prior to the latest date for submission and completion of the Tender.

1.1.3.2 "Commencement Date" means the date notified under Sub-Clause 8.1 [Commencement of Works].

1.1.3.3 "Time for Completion" means the time for completing the Works or a Section (as the case may be) under Sub-Clause 8.2 [Time for Completion], as stated in the Contract

Data (with any extension under Sub-Clause 8.4 [Extension of Time for Completion]), calculated from the Commencement Date.

1.1.3.4 "Tests on Completion" means the tests which are specified in the Contract or agreed by both Parties or instructed as a Variation, and which are carried out under Clause 9 [Tests on Completion] before the Works or a Section (as the case may be) are taken over by the Employer.

1.1.3.5 "Taking-Over Certificate" means a certificate issued under Clause 10 [Employer's Taking Over].

1.1.3.6 "Tests after Completion" means the tests (if any) which are specified in the Contract and which are carried out in accordance with the Specification after the Works or a Section (as the case may be) are taken over by the Employer.

1.1.3.7 "Defects Notification Period" means the period for notifying defects in the Works or a Section (as the case may be) under Sub-Clause 11.1 [Completion of Outstanding Work and Remedying Defects], which extends over twelve months except if otherwise stated in the Contract Data (with any extension under Sub-Clause 11.3 [Extension of Defects Notification Period]), calculated from the date on which the Works or Section is completed as certified under Sub-Clause 10.1 [Taking Over of the Works and Sections].

1.1.3.8 "Performance Certificate" means the certificate issued under Sub-Clause 11.9 [Performance Certificate].

1.1.3.9 "day" means a calendar day and "year" means 365 days.

1.1.4

Money and Payments

1.1.4.1 "Accepted Contract Amount" means the amount accepted in the Letter of Acceptance for the execution and completion of the Works and the remedying of any defects.

1.1.4.2 "Contract Price" means the price defined in Sub-Clause 14.1 [The Contract Price], and includes adjustments in accordance with the Contract.

1.1.4.3 "Cost" means all expenditure reasonably incurred (or to be incurred) by the Contractor, whether on or off the Site, including overhead and similar charges, but does not include profit.

1.1.4.4 "Final Payment Certificate" means the payment certificate issued under Sub-Clause 14.13 [Issue of Final Payment Certificate].

1.1.4.5 "Final Statement" means the statement defined in Sub-Clause 14.11 [Application for Final Payment Certificate].

1.1.4.6 "Foreign Currency" means a currency in which part (or all) of the Contract Price is payable, but not the Local Currency.

1.1.4.7 "Interim Payment Certificate" means a payment certificate issued under Clause 14 [Contract Price and Payment], other than the Final Payment Certificate.

1.1.4.8 "Local Currency" means the currency of the Country.

1.1.4.9 "Payment Certificate" means a payment certificate issued under Clause 14 [Contract Price and Payment].

1.1.4.10 "Provisional Sum" means a sum (if any) which is specified in the Contract as a provisional sum, for the execution of any part of the Works or for the supply of Plant, Materials or services under Sub-Clause 13.5 [Provisional Sums].

1.1.4.11 "Retention Money" means the accumulated retention moneys which the Employer retains under Sub-Clause 14.3 [Application for Interim Payment Certificates] and pays under Sub-Clause 14.9 [Payment of Retention Money].

1.1.4.12 "Statement" means a statement submitted by the Contractor as part of an application, under Clause 14 [Contract Price and Payment], for a payment certificate.

1.1.5

Works and Goods

1.1.5.1 "Contractor's Equipment" means all apparatus, machinery, vehicles and other things required for the execution and completion of the Works and the remedying of any defects. However, Contractor's Equipment excludes Temporary Works, Employer's Equipment (if any), Plant, Materials and any other things intended to form or forming part of the Permanent Works.

1.1.5.2 "Goods" means Contractor's Equipment, Materials, Plant and Temporary Works, or any of them as appropriate.

1.1.5.3 "Materials" means things of all kinds (other than Plant) intended to form or forming part of the Permanent Works, including the supply-only materials (if any) to be supplied by the Contractor under the Contract.

1.1.5.4 "Permanent Works" means the permanent works to be executed by the Contractor under the Contract.

1.1.5.5 "Plant" means the apparatus, machinery and vehicles intended to form or forming part of the Permanent Works, including vehicles purchased for the Employer and relating to the construction or operation of the Works.

1.1.5.6 "Section" means a part of the Works specified in the Contract Data as a Section (if any).

1.1.5.7 "Temporary Works" means all temporary works of every kind (other than Contractor's Equipment) required on Site for the execution and completion of the Permanent Works and the remedying of any defects.

1.1.5.8 "Works" mean the Permanent Works and the Temporary Works, or either of them as appropriate.

1.1.6

Other Definitions

1.1.6.1 "Contractor's Documents" means the calculations, computer programs and other software, drawings, manuals, models and other documents of a technical nature (if any) supplied by the Contractor under the Contract.

1.1.6.2 "Country" means the country in which the Site (or most of it) is located, where the Permanent Works are to be executed.

1.1.6.3 "Employer's Equipment" means the apparatus, machinery and vehicles (if any) made available by the Employer for the use of the Contractor in the execution of the Works, as stated in the Specification; but does not include Plant which has not been taken over by the Employer.

1.1.6.4 "Force Majeure" is defined in Clause 19 [Force Majeure].

1.1.6.5 "Laws" means all national (or state) legislation, statutes, ordinances and other laws, and regulations and by-laws of any legally constituted public authority.

1.1.6.6 "Performance Security" means the security (or securities, if any) under Sub-Clause 4.2 [Performance Security].

1.1.6.7 "Site" means the places where the Permanent Works are to be executed, including storage and working areas, and to which Plant and Materials are to be delivered, and any other places as may be specified in the Contract as forming part of the Site.

1.1.6.8 "Unforeseeable" means not reasonably foreseeable by an experienced contractor by the Base Date.

1.1.6.9 "Variation" means any change to the Works, which is instructed or approved as a variation under Clause 13 [Variations and Adjustments].

1.2

Interpretation

In the Contract, except where the context requires otherwise:

- (a) words indicating one gender include all genders;
- (b) words indicating the singular also include the plural and words indicating the plural also include the singular;
- (c) provisions including the word "agree", "agreed" or "agreement" require the agreement to be record in writing;
- (d) "written" or "in writing" means hand-written, type-written, printed or electronically made, and resulting in a permanent record; and
- (e) the word "tender" is synonymous with "bid", and "tenderer" with "bidder" and the words "tender documents" with "bidding documents".

The marginal words and other headings shall not be taken into consideration in the interpretation of these Conditions.

In these Conditions, provisions including the expression "Cost plus profit" require this profit to be one-twentieth (5%) of this Cost unless otherwise indicated in the Contract Data.

1.3

Communications

Wherever these Conditions provide for the giving or issuing of approvals, certificates, consents, determinations, notices, requests and discharges, these communications shall be:

- (a) in writing and delivered by hand (against receipt), sent by mail or courier, or transmitted using any of the agreed systems of electronic transmission as stated in the Contract Data; and
- (b) delivered, sent or transmitted to the address for the recipient's communications as stated in the Contract Data. However:
 - (i) if the recipient gives notice of another address, communications shall thereafter be delivered accordingly; and
 - (ii) if the recipient has not stated otherwise when requesting an approval or consent, it may be sent to the address from which the request was

issued.

Approvals, certificates, consents and determinations shall not be unreasonably withheld or delayed. When a certificate is issued to a Party, the certifier shall send a copy to the other Party. When a notice is issued to a Party, by the other Party or the Engineer, a copy shall be sent to the Engineer or the other Party, as the case may be.

1.4
Law and Language

The Contract shall be governed by the law of the country or other jurisdiction stated in the Contract Data.

The ruling language of the Contract shall be that stated in the Contract Data.

The language for communications shall be that stated in the Contract Data. If no language is stated there, the language for communications shall be the ruling language of the Contract.

1.5
Priority of Documents

The documents forming the Contract are to be taken as mutually explanatory of one another. For the purposes of interpretation, the priority of the documents shall be in accordance with the following sequence:

- (a) the Contract Agreement (if any),
- (b) the Letter of Acceptance,
- (c) the Tender,
- (d) the Particular Conditions - Part A,
- (e) the Particular Conditions - Part B,
- (f) these General Conditions,
- (g) the Specification,
- (h) the Drawings, and
- (i) the Schedules and any other documents forming part of the Contract.

If an ambiguity or discrepancy is found in the documents, the Engineer shall issue any necessary clarification or instruction.

TABLE OF CONTENTS

PART II - SPECIAL/PARTICULAR CONDITIONS OF CONTRACT

Clause	Title	Page
1.1	Definitions	
3.1	Engineer's Duties and Authority	145
4.3	Contractor's Representative	
6.10	Records of Contractor's Personnel and equipment	145
7.9	Use of Pakistani Materials and Services	145
8.1	Commencement of Works	145
8.11	Prolonged Suspension	145
8.3	Programme	
13.1	Right to vary	
13.3	Variation procedure	
13.8	Adjustment for changes in cost	
14.1	Contract Price	
14.2	Advance Payment	
14.5	Plants and Materials intended for Works	
14.8	Delayed Payments	
15.2	Termination by Employer/Procuring Agency	
15.6	Corrupt and fraudulent Practices (Integrity Pact).	
16.4	Payment on Termination	
17.3	Employer's/Procuring Agency's Risks	
18.1	General Requirements for Insurance	
19.6	Optional Termination, Payment and release by the Employer	
20.1	Contractor's Claims	
20.2	Appointment of the Dispute Board / Notification of the Committee	
20.3	Failure to agree on the composition of the Dispute Board.	
20.4	Obtaining Dispute Board's Decision	
20.5	Amicable Settlement.	
20.6	Arbitration	
20.7	Failure to comply with Dispute Board's Decision	
20.8	Expiry of Dispute Board's Appointment	
APPE		
NDIX.	General Conditions of Dispute Board Agreement	
Annex	PROCEDURAL RULES	

of hired Contractor's Equipment, forthwith notify the Engineer in writing the name and address of the Owner of the equipment and shall certify that the agreement for the hire thereof contains a provision in accordance with the requirements set forth above.

The following sub-clause 7.9 is added in (GCC):

7.9 Use of Pakistani Materials and Services

The contractor shall, so far as may be consistent with the contract, make the maximum use of materials, supplies, plant and equipment indigenous to or produced or fabricated in Pakistan and services, available in Pakistan provided such materials, supplies, plant, equipment and services shall be of required standard.

8.1 Commencement of Works

The last para is deleted and substituted with the following:

The contractor shall commence the works on site within the period named in Appendix-A to Bid from the date of receipt by him from the Engineer of a written Notice to Commence. Thereafter, the contractor shall proceed with the works with due expedition and without delay.

8.11 Prolonged Suspension

Replace 84 days by 120 days.

8.3 Programme

The following text is to be added after [Commencement of Works]

The programme shall be submitted in the either form of:

- a) Bar Chart identifying the critical activities.
- b) Critical Path Method (CPM) identifying the critical path/activities.
- c) Program Evaluation and Review Techniques (PERT).
(Procuring Agency to select appropriate one)

13.1 Right to vary

In the last line of Para, after the word "Variation", the word "in writing" is added.

13.3 Variation procedure

In the tenth line, after the words "as soon as practicable" following is added:
"and within a period not exceeding one-eighth of the completion time"

13.8 Adjustment for changes in cost

This clause will be applicable for Foreign funded Project/ Schemes or ICB Contracts (locally & foreign funded) only.

The following provision is added for Local funded Project/ Schemes/National Competitive Bidding Contracts:

The amounts payable to the Contractor, pursuant to Sub-Clause 14.6, shall be adjusted in respect of the rise or fall in the cost of materials only, and will be paid to the contractor on those items mentioned in the Appendix –C (B).

Similarly reduction in the cost of these materials will also be recovered from the contractor accordingly

14.1 The Contract Price
Sub-para (d) is deleted.

14.2 Advance Payment

The Text is deleted and replaced with following:

Advance Payment/Mobilization Advance shall be made available to the Contractor by the procuring agency on following conditions:

Mobilization Advance/Advance Payment

- (i) Mobilization advance up to 10 % of the Contract Price may be paid by the procuring agency to the Contractor on the works costing Rs2.5 million or above on following conditions:
 - a. on submission by the Contractor of a mobilization advance guarantee for the full amount of the advance in the specified form, from a Scheduled Bank in Pakistan, acceptable to the procuring agency;
 - b. contractor shall pay interest on the mobilization advance at the rate of 10% per annum on the advance; and
- (ii) This Advance including the interest shall be recovered in 5 equal installments from the 5 R.A bills and in case the number of bills is less than 5 then 1/5 of the advance inclusive of the interest thereon shall be recovered from each bill and the balance together with interest be recovered from the final bill. It may be insured that there is sufficient amount in the final bill to enable recovery of the Mobilization Advance.

14.5 Plants and Materials intended for Works

Add the following paragraph as sub-clause 14.5 (d) for Secured Advance on non - perishable materials and sub-clauses (a), (b) and (c) will be applicable for plants only :-

- (I) The Contractor shall be entitled to receive from the procuring agency Secured Advance against an INDENTURE BOND in Public Works Account Form No.31 (Fin. R. Form No. 2) acceptable to the procuring agency of such sum as the Engineer may consider proper in respect of non-perishable materials brought at the site but not yet incorporated in the Permanent Works provided that:
 - (i) The materials are in accordance with the specifications for the permanent works;
 - (ii) Such materials have been delivered to the site and are properly stored and protected against loss or damage or deterioration to the satisfaction and verification of the Engineer/Assistant Engineer but at the risk and cost of the Contractor;
 - (iii) The Contractor's records of the requirements, orders, receipts and use of materials are kept in a form approved by the Engineer, and such records shall be available for inspection by the Engineer;
 - (iv) The Contractor shall submit with his monthly statement the estimated value of the materials on site together with such documents as may be required by the Engineer for the purpose of valuation of materials and providing evidence of ownership and payment therefore;

- (v) Ownership of such materials shall be deemed to vest in the procuring agency and these materials shall not be removed from the site or otherwise disposed of without written permission of the procuring agency;
- (vi) The sum payable for such materials on site shall not exceed 75 % of the (i) landed cost of imported materials, or (ii) ex-factory / ex-warehouse price of locally manufactured or produced materials, or (iii) market price of stands other materials;
- (vii) Secured Advance shall not be allowed unless and until the previous advance, if any, is fully recovered;
- (viii) Detailed account of advances must be kept in part II of running account bill or a separate statement; and
- (ix) Secured Advance may be permitted only against materials/quantities anticipated to be consumed / utilized on the work within a period of 3 months from the date of issue of secured advance and in no case for full quantities of materials for the entire work/contract.

(II) Recovery of Secured Advance:

Secured Advance paid on non-perishable materials to the Contractor under the above provisions shall be effected from the monthly payments on actual consumption basis, but not later than period specified in the rules not more than three months (even if unutilized);

14.8 Delayed Payment

Second Para is replaced with following text:

In the event of the failure of the Procuring Agency to make the payment within the time stated, the procuring agency shall pay to the contractor in case of **ICB contracts only**, the compensation at rate of KIBOR+2% per annum in local currency and Libor+1% for foreign currency, upon all sums to be paid from the date of which the same would have been paid.

15.2 Termination by Employer

The following Para is added at the end of the sub-clause:

Provided further, that in addition to the action taken by the procuring agency against the Contractor under this Clause, the procuring agency may also refer the case of default of the Contractor to Pakistan Engineering Council for punitive action under the Construction and Operation of Engineering Works Bye-Laws 1987, as amended from time to time.

15.6 Corrupt and fraudulent Practices.

The following text is to be added as 3rd paragraph:

Successful Contractor has to provide Integrity Pact (for contracts worth Rs.10.0 million and above).

If the Contractor or any of his Subcontractors, agents or servants is found to have violated or involved in violation of the Integrity Pact signed by the Contractor as Appendix-L to his Bid, then the procuring agency shall be entitled to:

- (a) recover from the Contractor an amount equivalent to ten times the sum of any commission, gratification, bribe, finder's fee or kickback given by the Contractor or any of his Subcontractors, agents or servants;
- (b) terminate the Contract; and
- (c) recover from the Contractor any loss or damage to the procuring agency as a result of such termination or of any other corrupt business practices of the Contractor or any of his Subcontractors, agents or servants.

The termination under sub-para (b) of this Sub-Clause shall proceed in the manner prescribed under sub-clauses 15.2 & 15.5, and the payment under Sub-Clause 15.4 shall be made after having deducted the amounts due to the procuring agency under Sub-Para (a) and (c) of this Sub-Clause.

16.4 Payment on Termination
Sub-paragraph (c) is deleted.

17.3 Employer's/ Procuring Agency's Risks

Sub-Clause 17.3 (h) is deleted.

The following text is added in Clause 18.1 (GCC):

18.1 General Requirements for Insurance

The contractor shall be obliged to place all insurances relating to the contract (including, but not limited to, the insurances referred to in Clauses 18.1,18.2,18.3,18.4) with Insurance Company having at least AA rating from PACRA/JCR in favour of the Employer/Procuring Agency valid for a period 28 days after beyond the Bid Validity date. Costs of such insurances shall be borne by the contractor.

19.6 Optional Termination, Payment and release by the Employer
Sub-clauses (c), (d) and (e) are deleted.

20.6 Arbitration

Text will be replaced as under;

Any dispute in respect of which;

- (a) *the decision, of the Dispute Board has not become final and binding pursuant to sub-clause 20.2, and*
- (b) *amicable settlement has not been reached within the period stated in sub-clause 20.5, shall be finally settled, under the provisions of the Arbitration Act, 1940 as amended or any statutory modification/Rules of Conciliation And Arbitration PEC Islamabad or re-enactment thereof for the time being in force.*

The place of arbitration shall be, in Sindh Province.

Procuring Agency can retain this clause without changes, in case of contracts under Project,

Bank and donor's programme except the place of arbitration shall be in Sindh Province.

Annex PROCEDURAL RULES

Procuring Agency can retain these rules with or without changes, in case of contracts under Project, Bank and donor's programme.

PART II - SPECIAL/PARTICULAR CONDITIONS OF CONTRACT

INDEX	CLAUSE
Adjustment for changes in cost	13.8
Advance Payment	14.2
Amicable Settlement	20.5
Appointment of the Dispute Board / Notification of the Committee	20.2
Arbitration	20.6
Commencement of Works	8.1
Contractor's Representative	4.3
Contractor's Claims	20.1
Contract Price	14.1
Corrupt and fraudulent Practices (Integrity Pact)	15.6
Definitions	1.1
Delayed Payments	14.8
Employer's/Procuring Agency's Risks	17.3
Engineer's Duties and Authority	3.1
Expiry of Dispute Board's Appointment	20.8
Failure to agree on the composition of the Dispute Board	20.3
Failure to comply with Dispute Board's Decision	20.7
General Conditions of Dispute Board Agreement	Appendix
General Requirements for Insurance	18.1
Optional Termination, Payment and release by the Employer	19.6
Obtaining Dispute Board's Decision	20.4
Payment on Termination	15.6
Plants and Materials intended for Works	14.5
PROCEDURAL RULES	Annex
Prolonged Suspension	8.11
Programme	8.3
Records of Contractor's Personnel and equipment	6.10
Right to vary	13.1
Termination by Employer/Procuring Agency	15.2
Use of Pakistani Materials and Services	7.9
Variation procedure	13.3

DRAWINGS

SECTION OF STONE PITCHING, PROFILE AND C/FORT ALONG P.F.L

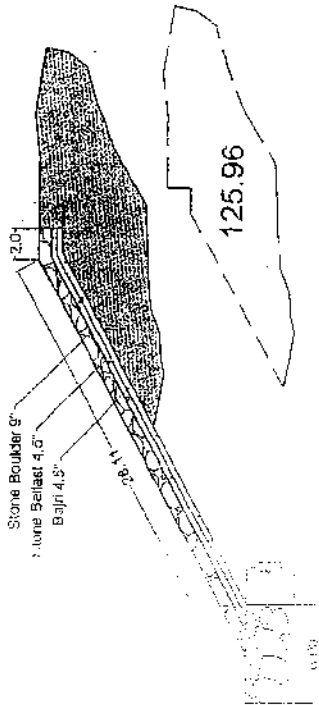

Stone Pitching

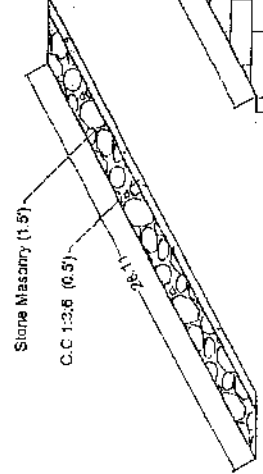

Profile

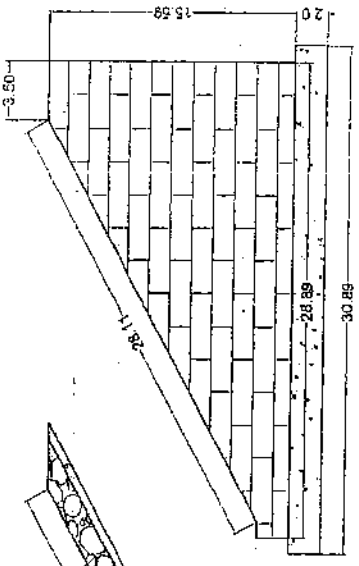

C/Fort

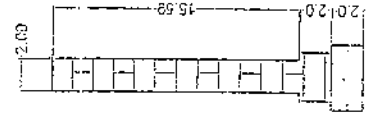

C/Fort

SUB ENGINEER

ASSISTANT EXECUTIVE ENGINEER
DARRO SUB DIVISION

[Handwritten Signature]
EXECUTIVE ENGINEER
UPPER PIRYARI DIVISION
HYDERABAD

SPECIFICATIONS

**FORM OF BID
AND
APPENDICES TO BID**

FORM OF BID

Bid Reference No. _____
 (Name of Contract/Work)

To: _____

1. Having examined the bidding documents including Instructions to Bidders, Bidding Data, and Conditions of Contract, Specifications, Drawings and Bill of Quantities and Addenda Nos. _____ for the execution of the above-named work, we/I, the undersigned, offer to execute and complete the work and remedy any defects therein in conformity with the Conditions of Contract, Specifications, Drawings, Bill of Quantities and Addenda for the sum of _____ (Rupees _____) or such other sum as may be ascertained in accordance with the said conditions.
 2. We/I understand that all the Appendices attached hereto form part of this bid.
 3. As security for due performance of the undertakings and obligations of this bid, we/I submit herewith a bid security in the amount of Rupees _____ (Rs. _____) drawn in your favour or made payable to procuring agency and valid for a period of _____ days beginning from the date, bid is opened.
 4. We/I undertake, if our bid is accepted, to commence the works and to complete the whole of the works comprised in the contract within the time stated in Appendix-A to Bid.
 5. We/I agree to abide by this bid for the period of _____ days from the date fixed for opening the same and it shall remain binding upon us and may be accepted at any time before the expiration of that period.
 6. Unless and until a formal Agreement is prepared and executed, this bid, together with your written acceptance thereof, shall constitute a binding contract between us.
 7. We do hereby declare that the bid is made without any collusion, comparison of figures or arrangement with any other bidder for the works.
- We understand that you are not bound to accept the lowest or any bid you may receive.
9. We undertake, if our/my bid is accepted, to execute the Performance Security referred to in Clause 10 of Conditions of Contract for the due performance of the Contract.
 10. We confirm, if our bid is accepted, that all partners of the joint venture shall be liable jointly and severally for the execution of the Contract and the composition or the constitution

of the joint venture shall not be altered without the prior consent of the procuring agency.
(Please delete this in case of Bid form a single bidder)

in the capacity of _____ duly authorized to sign Bids for and on behalf of

Dated this _____ day of _____ 20____

Signature: _____

(Name of Bidder in Block Capitals)
(Seal)

Address: _____

Witness:

Signature: _____
Name: _____

Address: _____

Occupation: _____

SPECIAL STIPULATIONS

Clause

Conditions of Contract

1.	Engineer representing Consulting Firm hired by the procuring agency to issue variation in case of emergency.	3.1	Up to 2% of the contract price stated in the Letter of Acceptance.
2.	Amount of Performance Security	4.2	Up to 10% of contract price. Total amount including performance security and retention money deducted from bills should not exceed 10% of contract price stated in the Letter of Acceptance.
3.	Time for Furnishing Programme	8.3	Within 42 days from the date of receipt of Letter of Acceptance.
4.	Minimum amount of Third Party Insurance	18.3	Rs. _____ per occurrence with number of occurrences unlimited.
5.	Time for Commencement	8.1	Within 14 days from the date of receipt of Engineer's Notice to Commence, this shall be issued within fourteen (14) days after signing of Contract Agreement.
6.	Time for Completion (works & sections)	8.2 & 10.2	_____ days from the date of receipt of Engineer's Notice to Commence.
7.	Amount of Liquidity Damages/Delay Damages/Penalties	8.7	-----Damages per day (are to be mentioned) but total amount will not be more than 10% of contract Price.
8.	Defects Liability Period	11.1	_____ days from the effective date of Taking Over Certificate.
9.	Percentage of Retention Money	14.2	10 % of the amount of Interim/Running Payment Certificate.
10.	Limit of Retention Money	14.2	5 % of Contract Price stated in the Letter of Acceptance.
11.	Minimum amount of Interim/Running Payment Certificates	14.2	Rs. _____
12.	Time of Payment from delivery of Engineer's Interim/Running Payment Certificate to the procuring agency.	14.7	30 days in case of local currency or 42 days in case of foreign funded projects.
13.	Mobilization Advance.	14.2	10% of Contract Price stated in the Letter of Acceptance.

FOREIGN CURRENCY REQUIREMENTS

1. The bidder may indicate herein below his requirements of foreign currency (if any), with reference to various inputs to the works.
2. Foreign Currency Requirement as percentage of the bid price excluding Provisional Sums _____%.
3. Table of Exchange Rates

Unit of Currency	Equivalent in Pak. Rupees
Australian Dollar	_____
Euro	_____
Japanese Yen	_____
U.K. Pound	_____
U.S. Dollars	_____
_____	_____
_____	_____

**PRICE ADJUSTMENT UNDER CLAUSE 70/13.8
OF CONDITIONS OF CONTRACT**

A. Weight ages or coefficients are used for price adjustment.

The source of indices and the weight ages or coefficients for use in the adjustment formula under Clause 13.8 shall be as follows:
(To be filled by the procuring agency)

Cost Element	Description	Weight ages	Applicable index
1	2	3	4
(i)	Fixed Portion	0.350	
(ii)	Local Labor		Government of Pakistan (GoP) Federal Bureau of Statistics (FBS) Monthly Statistical Bulletin.
(iii)	Cement - in bags		" " "
(iv)	Reinforcing Steel		" " "
(v)	High Speed Diesel (HSD)		" " "
(vi)	Bricks		" " "
(vii)	Bitumen		" " "
(viii)			" " "
	Total	1.000	

Notes:

- 1) Indices for "(ii)" to "(vii)" are taken from the Government of Pakistan Federal Bureau of Statistics, Monthly Statistical Bulletin. The base cost indices or prices shall be those applying 15 days prior to the latest day for submission of bids. Current indices or prices shall be those applying 28 days prior to the last day of the billing period.
- 2) Any fluctuation in the indices or prices of materials other than those given above shall not be subject to adjustment of the Contract Price.
- 3) Fixed portion shown here is for typical road project, procuring agency to determine the weight age of Fixed Portion considering only those cost elements having cost impact of seven (7) percent or more on his specific project.

B When Escalation is allowed on the materials only.
Price adjustment on following items shall be allowed:

Cost Element 1	Description 2	Base price 3	Applicable index 4
(i)	Cement - in bags		Government of Pakistan (GoP) Federal Bureau of Statistics (FBS) Monthly Statistical Bulletin. " " "
(ii)	Reinforcing Steel		" " "
(iii)	Bricks		" " "
(iv)	Bitumen		" " "
(v)	Wood (Composite item)		" " "
	Total five items.		

BILL OF QUANTITIES

A. Preamble

1. The Bill of Quantities shall be read in conjunction with the Conditions of Contract, Specifications and Drawings.
2. The quantities given in the Bill of Quantities are estimated and provisional, and are given to provide a common basis for bidding. The basis of payment will be the actual quantities of work executed and measured by the Contractor and verified by the Engineer and valued at the rates and prices entered in the priced Bill of Quantities, where applicable, and otherwise at such rates and prices as the Engineer may fix as per the Contract (in case of item not mentioned in Bill of Quantities).
3. The rates and prices entered in the priced Bill of Quantities shall, except insofar as it is otherwise provided under the contract include all costs of contractor's plant, labour, supervision, materials, execution, insurance, profit, taxes and duties, together with all general risks, liabilities and obligations set out or implied in the contract. Furthermore all duties, taxes and other levies payable by the contractor under the contract, or for any other cause, as on the date 14 days prior to deadline for submission of Bids in case of ICB/NCB respectively, shall be included in the rates and prices and the total bid price submitted by the bidder.
4. A rate or price shall be entered against each item in the priced Bill of Quantities, whether quantities are stated or not. The cost of items against which the contractor will have failed to enter a rate or price shall be deemed to be covered by other rates and prices entered in the Bill of Quantities and shall not be paid separately.
5. The whole cost of complying with the provisions of the Contract shall be included in the items provided in the priced Bill of Quantities, and where no items are provided, the cost shall be deemed to be distributed among the rates and prices entered for the related items of the works.
6. General directions and description of work and materials are not necessarily repeated nor summarised in the Bill of Quantities. References to the relevant sections of the bidding documents shall be made before entering prices against each item in the priced Bill of Quantities.
7. Provisional sums included and so designated in the Bill of Quantities shall be expended in whole or in part at the direction and discretion of the Engineer in accordance with sub-clause 13.5 of Part I, General Conditions of Contract.

BILL OF QUANTITIES (SAMPLE)

B. Work Items. (Road /PHE Work)*

1. The Bill of Quantities contains the following Bills and Items:

Bill No. 1	-	Earthworks
Bill No. 2	-	Hard Crust and Surface Treatment
Bill No. 3	-	Culverts and Bridges
Bill No. 4	-	Subsurface Drains, Pipe Laying and Man holes
Bill No. 5	-	Tube wells, Pump houses and Compound wall
Bill No. 6	-	Miscellaneous Items

Day work Schedule
Summary Bill of Quantities

2. Bidders shall price the Bill of Quantities in Pakistani Rupees only.

**Procuring Agency can add and delete the Items as per its requirement.*

BILL OF QUANTITIES (SAMPLE)***B. Work Items (Buildings)**

1. The Bill of Quantities contains the following Bills and Items:

Bill No. 1	-	Plinth and Foundation.
Bill No. 2	-	Ground floor.
Bill No. 3	-	First and Subsequent Floors.
Bill No. 4	-	Internal Water Supply and Sanitary Fittings.
Bill No. 5	-	Internal Electrification.
Bill No. 6	-	Miscellaneous Items
Bill No. 7	-	External Development

Day work Schedule

Summary Bill of Quantities

2. Bidders shall price the Bill of Quantities in Pakistani Rupees only.

* *Procuring Agency can add and delete the Items as per its requirement*

BILL OF QUANTITIES (SAMPLE)

Bill No. 1 Earthworks/Plinth and Foundation

Item	Description	Unit	Quantity	Rate		Amount
				Rupees in figures	Rupees in words	Rupees
1	2	3	4	5		6
101						
102						
103						
104						
105						
106						
Total for Bill No. 1 (Carried forward to Summary Page)						

BILL OF QUANTITIES (SAMPLE)

Bill No. 2 Hard Crust and Surface Treatment /Ground Floor.

Item	Description	Unit	Quantity	Rate		Amount Rupees
				Rupees in figures	Rupees in words	
1	2	3	4	5		6
201						
202						
203						
204						
205						
206						
Total for Bill No. 2 (Carried forward to Summary Page)						

BILL OF QUANTITIES (SAMPLE)

Bill No. 3 Culverts and Bridges/First and Subsequent Floors

Item	Description	Unit	Quantity	Rate		Amount
				Rupees in figures	Rupees in words	Rupees
1	2	3	4	5		6
301						
302						
303						
304						
305						
306						
Total for Bill No. 3						
(Carried forward to Summary Page)						

BILL OF QUANTITIES (SAMPLE)

Bill No. 4 Subsurface Drains/ Pipe Laying and Man holes/Internal water Supply and Sanitary Fittings

Item	Description	Unit	Quantity	Rate		Amount
				Rupees in figures	Rupees in words	Rupees
1	2	3	4	5		6
401						
402						
403						
404						
205						
406						
Total for Bill No. 4						
(Carried forward to Summary Page)						

BILL OF QUANTITIES (SAMPLE)

Bill No. 5 Tube wells and Pump-houses/Internal Electrification

Item	Description	Unit	Quantity	Rate		Amount
				Rupees in figures	Rupees in words	Rupees
1	2	3	4	5		6
501						
502						
503						
504						
505						
506						
Total for Bill No. 5 (Carried forward to Summary Page)						

Schedule "B"

**NAME OF WORK RESECTIONING OF GANJ BAHAR BRANCH EX: PFL RD. 0 TO 70, REPAIR OF HE
REGULATOR GANJ BAHAR BRANCH, REPAIR OF ROAD BRIDGE, DUMPING OF STONE.**

Quantity	item	Rate	Per	Amount
5600000 Sft.	1. Jungle clearance and removing within 100 ft (a) Light. [S.Item No.04(a), P-No.100]	75.63	%o Sft.	423,528.00
128.56 Acres	2. Ploughing 3 times [S.Item No.41, P-No.109]	1769.63	P.Acre	227,500.64
7088675 Cft.	3. Earth work excavation in irrigation channels drains etc, dressed to designed section grades and profiles excavated material disposed off and dressed within 50 ft lead. (a) Ordinary Soil. [S.Item No.5(a) P.No.4]	2420.00	%o Cft	17,154,593.50
13829380 Cft.	4. Borrowpit excavation undressed lead Upto 100 ft (a) Ordinary soil. (a) Ordinary Soil. [S.Item No.3(a) P.No.1]	2117.50	%o Cft.	29,283,712.15
3370353 Cft.	5. Carriage of 100 Cft/5 ton of all materail like stone aggregate, spawal, coal lime surkhi etc. B.G.Rail fastening joints and crossing bridges girders pipe sheet rail MS bars etc or 1000 Nos bricks 10"x3"x3" or 1000 Nos tiles 12"x6"x2" or 150 cft timber or 1000 Nos maund or fuel wood by trolley or any other means owned by contractors 2 Miles [S.Item No.1, P.No.1 Sch. Carriage]	407.00	% Cft	13,717,334.68
3370353 Cft.	6. Extrra for every 50 ft. additional lead of Part thereof. (a) For earth work (Soft,ordinary, hard and very hard 6x100.78) [S.Item No.8(a) P.No.2]	604.68	%o Cft.	2,037,984.75
3370353 Cft.	7. Rehandling of earth work (b) Upto a lead of 50 ft. [S.Item No.9(b) P.No.2]	1058.75	%o Cft.	3,568,361.24
				66,413,014.96

Quantity	item	Rate	Per	Amount
----------	------	------	-----	--------

66,413,014.96

13829380 Cft.	8. Earth work compaction (Soft, ordinary or hard soil. (a) Laying earth in 6 " Layers levelling and dressing watering for compaction complete etc. [S.Item No.13(b) P.No.4]	354.00	% Cft	4,895,600.52
------------------	-------------------------------------------------------------------------------------------------------------------------------------------------------------------------------------	--------	-------	--------------

G. Total Rs. **71,308,615.48**

Part B

Quantity	item	Rate	Per	Amount
----------	------	------	-----	--------

70.00 Cft.	1. Dismantling cement concrete reinforced separating reinforcement from concrete cleaning and strengthening the same [S.Item No.20 P.No.10]	5445.00	% Cft	3,811.50
---------------	--------------------------------------------------------------------------------------------------------------------------------------------------	---------	-------	----------

3540.00 Cft.	2. Dismntling brick work in lime or cemdnt mortar. [S.Item No.13 P.No.10]	1285.63	% Cft	45,511.30
-----------------	--------------------------------------------------------------------------------	---------	-------	-----------

3720.00 Cft.	3. Cement concrete plain i/c placing, compacting, finishing and curing complete (i/c screeding and washing of stone aggregate without shuttering). (f) Ratio 1:3:6	12595.00	% Cft	468,534.00
-----------------	------------------------------------------------------------------------------------------------------------------------------------------------------------------------	----------	-------	------------

1788.00 Cft.	(h) Ratio 12:4 [S.Item No.5(f)(h) P.No.18]	14429.25	% Cft	257,994.99
-----------------	-------------------------------------------------	----------	-------	------------

1788.00 Cft.	4. Pacca Brick work in foundation and plinth in Cement sand mortar 1:5 [S.Item No.4(i)(d), P.No.21]	12176.08	% Cft	217708.31
-----------------	----------------------------------------------------------------------------------------------------------	----------	-------	-----------

2340.00 Cft.	5. Pacca brick work other than building. i/c striking of joints upto 20' height in: (i) (d) Cement sand mortar 1:5 [S.Item No.7(i)(d), P.No.20]	12574.38	% Cft	294,240.12
-----------------	---------------------------------------------------------------------------------------------------------------------------------------------------------	----------	-------	------------

18.22 Cwt	6. (a) Fabrication of mild stell reinforcement for cement concrete i/c cutting, bending, laying in position making joints and fastenings i/c cost of binding wire (also includes removal of rust from bars) [S.Item No.8(a), P.No.17]	4820.2	P.Cwt	87,797.04
--------------	---------------------------------------------------------------------------------------------------------------------------------------------------------------------------------------------------------------------------------------------	--------	-------	-----------

1,375,597.26

Quantity	item	Rate	Per	Amount
				1,375,597.26
130.00 Cft	7. Reinforced cement concrete work i/c all labour and material except the cost of steel reinforcement and its labour for bending and binding which will be paid separately. The rate also includes all kinds of forms moulds lifting shuttering curing rendering and finishing the exposed surface (i/c screening and washing of shingle). (a) R.C.C.work in roof slab beams columns rafts lintels and other structural members laid in situ or precast laid in position completed in all respects. (i) Ratio (1:2:4) 90lbs cement 2 Cft sand 4 Cft shingle 1/8" to 1/4" gauge. [S.Item No.6(a)(i), P.No.17]	337.00	P.Cft	43,809.87
2120.00 Sft.	8. Cement Plaster 1:2 up to 12' height (b) Ratio 1:3 [S.Item No.9(c) P.No.52]	3056.62	% Sft.	64,800.34
	Total Rs.			1,484,207.48

Part C

Quantity	item	Rate	Per	Amount
965.00 Cft.	1. Dismantling cement concrete reinforced separating reinforcement from concrete cleaning and strengthening the same [S.Item No.20 P.No.10]	5445.00	% Cft	52,544.25
1740.00 Cft.	2. Dismantling stone masonry is lime cement. [S.Item No.3 P.No.9]	907.50	% Cft	15,790.50
2426.75 Cft.	3. Cement concrete plain i/c placing, compacting, finishing and curing complete (i/c screening and washing of stone aggregate without shuttering). (h) Ratio 12:4 [S.Item No.5(f)(h) P.No.18]	14429.25	% Cft	350,161.82

Quantity	item	Rate	Per	Amount
4. SUPER STRUCTURE.				
1740.00 Cft.	Coursed Rubble masonry hammer dressed. (d) In cement sand mortar (iii) Ratio 1:6 [S.Item No.4(d)(iii), P.No.33]	26588.46	% Cft	462,639.20
54.268 Cwt	5. (a) Fabrication of mild steel reinforcement for cement concrete i/c cutting, bending, laying in position making joints and fastenings i/c cost of binding wire (also includes removal of rust from bars) [S.Item No.8(a), P.No.17]	4820.2	P.Cwt	261,575.86
1013.00 Cft	6. Reinforced cement concrete work i/c all labour and material xcept the cost of steel reinforcement and its labour for bending and brinding which will paid separately. The rate also includes all kinds of forms moulds lifting shuttering curing rendering and finishing the exposed surface (i/c screening and washing of shingle). (a) R.C.C.work in roof slab beams columns rafts lintels and other structural members laid in situ or precast laid in position completed in all respects. (i) Ratio (1:2:4) 90lbs cement 2 Cft sand 4 Cft shingle 1/8" to 1/4" gauge. [S.Item No.6(a)(i), P.No.17]	337.00	P.Cft	341,380.87
1575.00 Sft.	7. Pointing flush on stone work. [c] On stone work raised. (ii) In cement mortar 1:3 [S.Item No.20(c) P.No.53]	1758.08	% Sft.	27,689.76
	Total Rs.			<u>1,511,781.58</u>

Part D

Quantity	item	Rate	Per	Amount
8000.00 Cft.	1. Supply stone boulders 9" and above. [S.Item No.60 P.No.04 Sch: of Material]	1400.00	% Cft.	112,000.00

Quantity	item	Rate	Per	Amount
8000.00 Cft.	2. Supply within 5 chains (a) Boulders 9" and above. [S.Item No.10(a) P.No.81]	1095.00	% Cft.	87,600.00
8000.00 Cft.	3. Dumping shingle, spawls and boulders i/c carriage material within 3 chains. [S.Item No.17 P.No.81]	529.38	% Cft.	42,350.40
				241,950.40

A=	71,308,615.48 ✓
B=	1,484,207.48 ✓
C=	1,511,781.58 ✓
D=	241,950.40 ✓
G. Total.	74,546,554.94 ✓

NB: No above premium is allowed to item No. 5 of part A.

Contractor

Executive Engineer,
Upper Pinyari Division,
Hyderabad.

BILL OF QUANTITIES (SAMPLE)

Bill No. 6 - Miscellaneous Items

Item	Description	Unit	Quantity	Rate		Amount Rupees
				Rupees in figures	Rupees in words	
1	2	3	4	5		6
601	Mobilization Cost					
602						
603						
604						
605						
606						
Total for Bill No. 6 Carried forward to Summary Page)						

BILL OF QUANTITIES (SAMPLE)

Bill No. 7			External Development			
Item	Description	Unit	Quantity	Rate		Amount
				Rupees in figures	Rupees in words	
1	2	3	4	5		6
601	Items of water supply & drainage					
602	Paths & parks					
603	External electrification					
604						
605						
606						
Total for Bill No. 7						
(Carried forward to Summary Page)						

BILL OF QUANTITIES**C. Day work Schedule****General**

- 1 Reference is made to Sub-Clause 13.6 of the General Conditions of Contract. Work shall not be executed on a day work basis except by written order of the Engineer. Bidders shall enter basic rates for day work items in the Schedules, which rates shall apply to any quantity of day work ordered by the Engineer. Nominal quantities have been indicated against each item of day work, and the extended total for day work shall be carried forward to the bid price.

Day work Labour

2. In calculating payments due to the contractor for the execution of day work, the actual time of classes of labour directly doing the day work ordered by the Engineer and for which they are competent to perform will be measured excluding meal breaks and rest periods. The time of gangers (charge hands) actually doing work with the gang will also be measured but not the time of foreman or other supervisory personnel.
3. The contractor shall be entitled to payment in respect of the total time that labour is employed on day work, calculated at the basic rates entered by him in the Schedule of day work Rates for labour together with an additional percentage, payment on basic rates representing the contractor's profit, overheads, etc., as described below:
 - a) the basic rates for labour shall cover all direct costs to the contractor, including (but not limited to) the amount of wages paid to such labour, transportation time, overtime, subsistence allowances and any sums paid to or on behalf of such labour for social benefits in accordance with Pakistan law. The basic rates will be payable in local currency only; and
 - b) the additional percentage payment to be quoted by the bidder and applied to costs incurred under (a) above shall be deemed to cover the contractor's profit, overheads, superintendence, liabilities and insurances and allowances to labour timekeeping and clerical and office work; the use of consumable stores, water, lighting and power; the use and repair of staging's, scaffolding, workshops and stores, portable power tools, manual plant and tools; supervision by the contractor's staff, foremen and other supervisory personnel; and charges incidental to the foregoing.

SCHEDULE OF DAYWORK RATES

I. Labour

Item No.	Description	Unit	Nominal Quantity	Rate (Rs) in Figure	Rate (Rs) in Words	Extended Amount (Rs.)
1	2	3	4	5	6	7
D101	Ganger	Hr	500			
D102	Labourer	Hr	5,000			
D103	Brick layer	Hr	500			
D.04	Mason	Hr	500			
D105	Carpenter	Hr	500			
D106	Steel work Erector	Hr	500			
	-----etc-----	Hr	500			
D113	Driver for vehicle up to 10 tons	Hr	1,000			
D114	Operator for excavator, dragline, shovel or crane	Hr	500			
D115	Operator for tractor, (tracked) with dozer blade or ripper	Hr	500			
D122	Sub Total					
	Allow _____ percent of subtotal for Contractor's overhead, profit, etc, in accordance with Paragraph 3(b) of Day work Schedule					
	Total for Day work: Labour : _____					
	(Carried forward to Day work Summary)					

Appendix-D to Bid

Day work Material

4. The contractor shall be entitled to payment in respect of materials used for day work (except for materials for which the cost is included in the percentage addition to labour costs as detailed heretofore), at the basic rates entered by him in the Schedule of Day work Rates for materials together with an additional percentage payment on the basic rates to cover overhead charges and profit, as follows:
 - a) the basic rates for materials shall be calculated on the basis of the invoiced price, freight, insurance, handling expenses, damage, losses, etc., and shall provide for delivery to store for stockpiling at the site. The basic rates shall be stated in local currency but payment will be made in the currency or currencies expended upon presentation of supporting documentation;
 - b) the additional percentage payment shall be quoted by the bidder and applied to the equivalent local currency payments made under Sub-Para(a) above; and
 - c) the cost of hauling materials used on work ordered to be carried out as Day work from the store or stockpile on the site to the place where it is to be used will be paid in accordance with the terms for Labour and Constructional Plant in this Schedule.

Appendix-D to Bid

SCHEDULE OF DAYWORK RATES

II. Materials

Item No.	Description	Unit	Nominal Quantity	Rate (Rs) in Figure	Rate (Rs) in Words)	Extended Amount (Rs.)
1	2	3	4	5	6	7
D201	Cement, ordinary Portland or equivalent in bags	M: Ton	200			
D202	Mild Steel reinforcing bar up to 16mm diameter to BS 4449 or equivalent	M: Ton	100			
D203	Fine aggregate for concrete as specified in Clause _____	Cu: M	1,000			
D204	-----etc-----					
D222	Gelignite (Noble Special Gelatine 60 % or equivalent) including caps, fuse, wire and requisite accessories	M: Ton	10			
D223	Sub Total					
	Allow _____ percent of subtotal for Contractor's overhead, profit, etc., in accordance with Paragraph 4(b) of Day work Schedule					
	Total for Day work: Materials _____					
	(Carried forward to Day work Summary) _____					

Appendix-D to Bid

Day Work Constructional Plant

5. The contractor shall be entitled to payments in respect of constructional plant already on site and employed on Day work at the basic rental rates entered by him in the Schedule of Day work Rates for constructional plant. The said rates shall be deemed to include complete allowance for depreciation, interest, indemnity and insurance, repairs, maintenance, supplies, fuel, lubricants, and other consumables, and all overhead, profit and administrative costs related to the use of such equipment. The cost of drivers, operators and assistants will be paid for separately as described under the section on Day work Labour.
6. In calculating the payment due to the Contractor for constructional plant employed on Day work, only the actual number of working hours will be eligible for payment, except that where applicable and agreed with the Engineer, the travelling time from the part of the site where the constructional plant was located when ordered by the Engineer to be employed on Day work and the time for return journey thereto shall be included for payment.
7. The basic rental rates for constructional plant employed on Day work shall be stated in Pakistani Rupees.

SCHEDULE OF DAYWORK RATES

II. Constructional Plant

Item No.	Description	Unit	Nominal Quantity	Rate (Rs.) in Figure	Rate Rs. in Words	Extended Amount (Rs.)
1	2	3	4		5	6
D301	Excavator, face shovel or dragline:					
	1. Up-to and including 1 Cu.M.	Hr	500			
	2. Over 1 Cu.M to 2 Cu. M.	Hr	400			
	3. Over 2 Cu. M	Hr	100			
D302	Tractor (tracked) including bull or angle dozer:					
	1. Up-to and including 150 HP	Hr	500			
	2. Over 150 to 200 HP	Hr	400			
	3. Over 200 to 250 HP	Hr	200			
D303	Tractor with ripper:					
	1. Up-to and including 200 HP	Hr	400			
	2. Over 200 to 250 HP	Hr	200			
D304	-----etc-----					
	Total for day work: Constructional Plant (Carried forward to day work summary)					

DAYWORK**Summary (Day work)**

	Amount (Rs.)
(I) Total for day work: Labour	_____
(II) Total for day work: Materials	_____
(III) Total for day work: Constructional Plant	_____
<hr/>	
Total for day work (Carried forward to summary page of Bill of Quantities)	_____

BILL OF QUANTITIES (SAMPLE)**SUMMARY**

	Amount (Rs.)
Bill No. 1: Earthworks/Plinth and Foundation	
Bill No. 2: Culverts and Bridges/Ground Floor	
Bill No. 3: Subsurface Drains/Internal Water Supply & Sanitary Fittings	
Bill No 4: Subsurface Drains/ Pipe Laying and Man holes/Internal water Supply and Sanitary Fittings	
Bill No. 5 Tube wells and Pump-houses/Internal Electrification	
Bill No. 6 Miscellaneous Items	
Bill No. 7 External Development	
Sub-Total of Bills	_____
Day work	_____
Bid Price	_____

Note: All Provisional Sums are to be expended in whole or, in part at the direction and discretion of the Engineer in accordance with Sub-Clauses 52.4 and 58.2 of the General Conditions of Contract Part- I.

Appendix-E to Bid

PROPOSED CONSTRUCTION SCHEDULE

Pursuant to Sub-Clause 43.1 of the General Conditions of Contract, the works shall be completed on or before the date stated in Appendix-A to Bid. The bidder shall provide as Appendix-E to Bid, the Construction Schedule in the bar chart (CPM, PERT or any other to be specified herein) showing the sequence of work items and the period of time during which he proposes to complete each work item in such a manner that his proposed programme for completion of the whole of the works and parts of the works may meet procuring agency's completion targets in days noted below and counted from the date of receipt of Engineer's Notice to Commence (Attach sheets as required for the specified form of Construction Schedule):

<u>Description</u>	<u>Time for Completion</u>
1) Whole works	_____ days
2) Part-A	_____ days
3) Part-B	_____ days
4) _____	_____ days
5) _____	_____ days

METHOD OF PERFORMING THE WORK

[The bidder is required to submit a narrative outlining the method of performing the work. The narrative should indicate in detail and include but not be limited to:

1. Organization Chart indicating head office and field office personnel involved in management and supervision, engineering, equipment maintenance and purchasing.
2. Mobilization in Pakistan, the type of facilities including personnel accommodation, office accommodation, provision for maintenance and for storage, communications, security and other services to be used.
3. The method of executing the works, the procedures for installation of equipment and machinery and transportation of equipment and materials to the site.

LIST OF MAJOR EQUIPMENT - RELATED ITEMS

[The bidder will provide on Sheet 2 of this Appendix a list of all major equipment and related items, under separate heading for items owned, to be purchased or to be arranged on lease by him to carry out the works. The information shall include make, type, capacity, and anticipated period of utilization for all equipment which shall be in sufficient detail to demonstrate fully that the equipment will meet all requirements of the Specifications.]

LIST OF MAJOR EQUIPMENT (SAMPLE)

Owned Purchased or Leased	Description of Unit (Make, Model, Year)	Capacity HP Rating	Condition	Present Location or Source	Date of Delivery at Site	Period of Work on Project
1	2	3	4	5	6	7
a. Owned						
b. To be Purchased						
c. To be arranged on Lease						

Appendix-H to Bid

CONSTRUCTION CAMP AND HOUSING FACILITIES

The Contractor in accordance with Clause 6 of the Conditions of Contract shall provide description of his construction camp's facilities and staff housing requirements.

The contractor shall be responsible for pumps, electrical power, water and electrical distribution systems, and sewerage system including all fittings, pipes and other items necessary for servicing the contractor's construction camp.

The bidder shall list or explain his plans for providing these facilities for the service of the contract as follows:

1. Site Preparation (clearing, land preparation, etc.).
2. Provision of Services.
 - a) Power (expected power load, etc.).
 - b) Water (required amount and system proposed).
 - c) Sanitation (sewage disposal system, etc.).
3. Construction of Facilities
 - a) Contractor's Office, Workshop and Work Areas (areas required and proposed layout, type of construction of buildings, etc.).
 - b) Warehouses and Storage Areas (area required, type of construction and layout).
 - c) Housing and Staff Facilities (Plans for housing for proposed staff, layout, type of construction, etc.).
4. Construction Equipment Assembly and Preparation (detailed plans for carrying out this activity).
5. Other Items Proposed (Security services, etc.).

LIST OF SUBCONTRACTORS

I/We intend to subcontract the following parts of the work to subcontractors. In my/our opinion, the subcontractors named hereunder are reliable and competent to perform that part of the work for which each is listed.

Enclosed are documentation outlining experience of subcontractors, the curriculum vitae and experience of their key personnel who will be assigned to the contract, equipment to be supplied by them, size, location and type of contracts carried out in the past.

Part of Works (Give Details)	Subcontractor (With Complete Address)
1	2

GUNG BAHAR.
 PLAN OF ROAD BRIDGE ALONG ~~EASTERN~~ W.M.H.
 RD. 698.

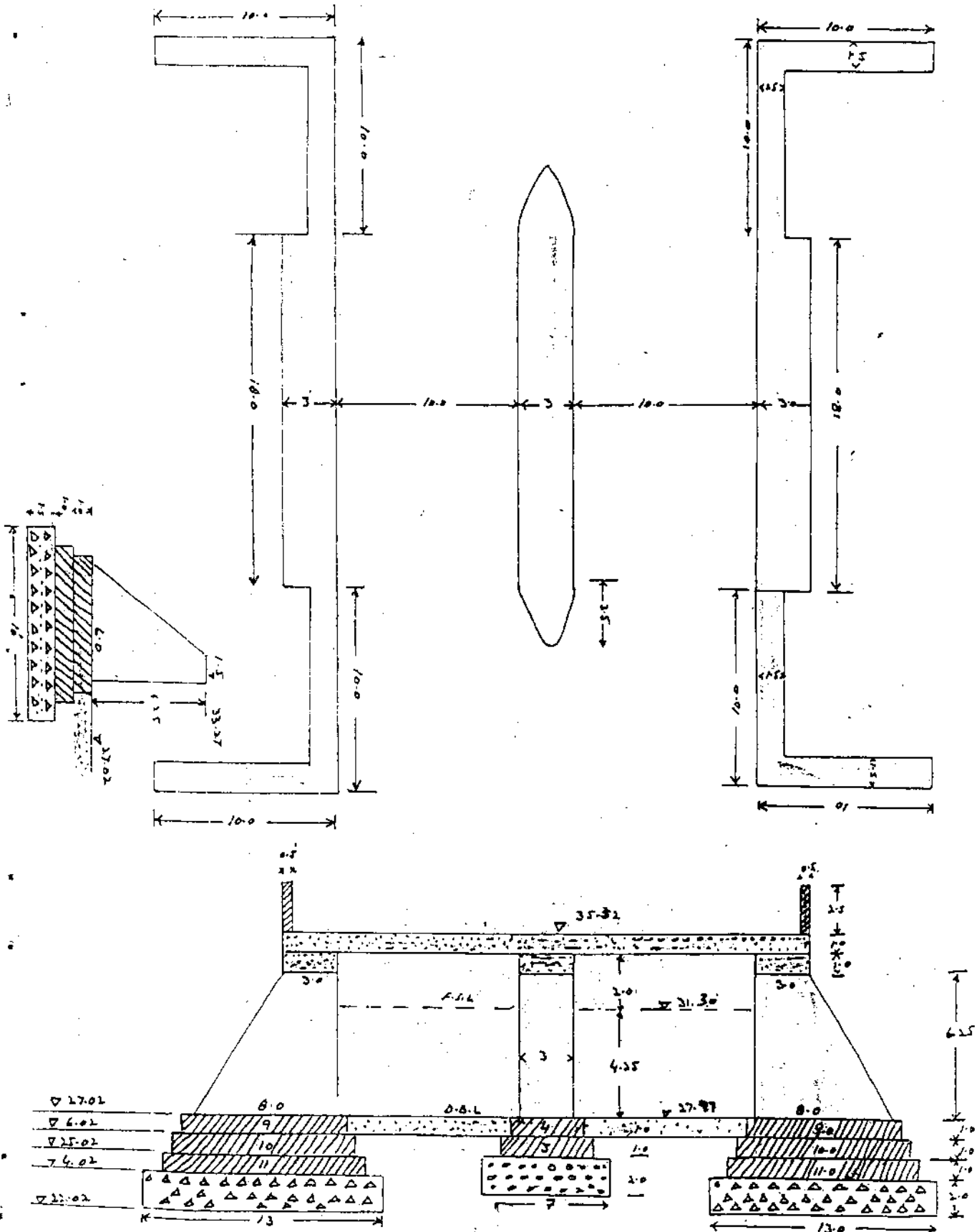

Assistant Executive Engineer,
 Darro Irrigation Sub Division.

[Signature]
 Executive Engineer,
 Upper Pinyari Division,
 Hyderabad.

RD	DOE	FAL	FSD	BL	D.D.S.A.	D.D.S.A.	DOE	DOE	FAL
0.0	34.01	41.21	7.20	50.0	51618				
1.0	33.94	41.14							
2.0	33.87	41.07							
3.0	33.80	41.0							
4.0	33.73	40.93							
5.0	33.67	40.86	6.79	50.0					
6.0	33.60	40.79							
7.0	33.53	40.72							
8.0	33.47	40.65							
9.0	33.40	40.58							
10.0	33.34	40.51	6.79	50.0					
11.0	33.27	40.44							
12.0	33.20	40.37							
13.0	33.14	40.31							
14.0	33.07	40.24							
15.0	33.01	40.17	5.95	50.0					
16.0	32.94	40.10							
17.0	32.87	40.03							
18.0	32.81	39.97							
19.0	32.74	39.90							
20.0	32.68	39.83	5.95	50.0					
21.0	32.61	39.77							
22.0	32.54	39.70							
23.0	32.48	39.63							
24.0	32.41	39.57							
25.0	32.35	39.50	5.95	50.0					
26.0	32.28	39.43							
27.0	32.21	39.37							
28.0	32.15	39.30							
29.0	32.08	39.23							
30.0	32.02	39.17	4.71	50.0					
31.0	31.94	39.10							
32.0	31.88	39.03							
33.0	31.81	38.97							
34.0	31.75	38.90							
35.0	31.68	38.83	4.71	50.0					

SECTION OF CROSS SECTION OF THE FIELD
 SHOWING RD AND FAL

SUBSTANTIVE EXECUTIVE ENGINEER
 IRRIGATION DISTRICT



R.D.	DATE	ESL	ESD	R.W.	DATE	ESL	ESD	R.W.
36+0	29.87	27.97						
37+0	29.86	27.86						
38+0	29.75	26.75						
39+0	29.64	26.64						
40+0	29.53	26.53						
41+0	29.41	26.41						
42+0	29.30	26.30						
43+0	29.18	26.18						
44+0	29.07	26.07						
45+0	28.95	25.95						
46+0	28.84	25.84						
47+0	28.73	25.73						
48+0	28.61	25.61						
49+0	28.50	25.50						
50+0	28.38	25.38						
51+0	28.26	25.26						
52+0	28.15	25.15						
53+0	28.03	25.03						
54+0	27.92	24.92						
55+0	27.80	24.80						
56+0	27.69	24.69						
57+0	27.57	24.57						
58+0	27.44	24.44						
59+0	27.31	24.31						
60+0	27.19	24.19						
61+0	27.07	24.07						
62+0	26.95	23.95						
63+0	26.82	23.82						
64+0	26.70	23.70						
65+0	26.58	23.58						
66+0	26.46	23.46						
67+0	26.34	23.34						
68+0	26.22	23.22						
69+0	26.10	23.10						
70+0	25.98	22.98						
71+0	25.86	22.86						
72+0	25.74	22.74						
73+0	25.62	22.62						
74+0	25.50	22.50						
75+0	25.38	22.38						
76+0	25.26	22.26						
77+0	25.14	22.14						
78+0	25.02	22.02						
79+0	24.90	21.90						
80+0	24.78	21.78						
81+0	24.66	21.66						
82+0	24.54	21.54						
83+0	24.42	21.42						
84+0	24.30	21.30						
85+0	24.18	21.18						
86+0	24.06	21.06						
87+0	23.94	20.94						
88+0	23.82	20.82						
89+0	23.70	20.70						
90+0	23.58	20.58						

SECTION OF CURVA DRENK TAN IEM P.ESI
 FROM R.D. 41.0 TO 90.0 P

ASSISTANT EXECUTIVE ENGINEER
 CANAL IRRIGATION SUBDIVISION, DAMEN

X. SECTION OF Street, Bridge & GR

R.D. 10

#50

#10

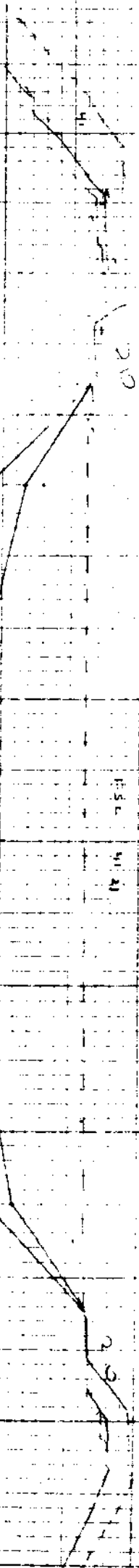

STATION	EXISTING DISTANCE	PROPOSED DISTANCE	WIDTH	WIDTH	WIDTH	WIDTH	WIDTH
0	0	0	34.01	36.60	34.01	0	0
8	8	8	34.01	36.60	34.01	0	0
15	15	15	34.01	36.60	34.01	7	9.06
25	25	25	34.01	36.60	34.01	10	12.90
35	35	35	34.01	36.60	34.01	0	0
60	60	60	34.01	36.60	34.01	10	12.90
72	72	72	34.01	36.60	34.01	7	9.06

DATE 10/10/10

AREA

BASE

WIDTH

DEPTH

PROPOSED

EXISTING

DISTANCE

38.96

36.60

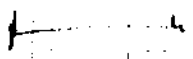

X SECTION OF TUNNEL MARK BR
R.D. 15-D
FILE NO. 93

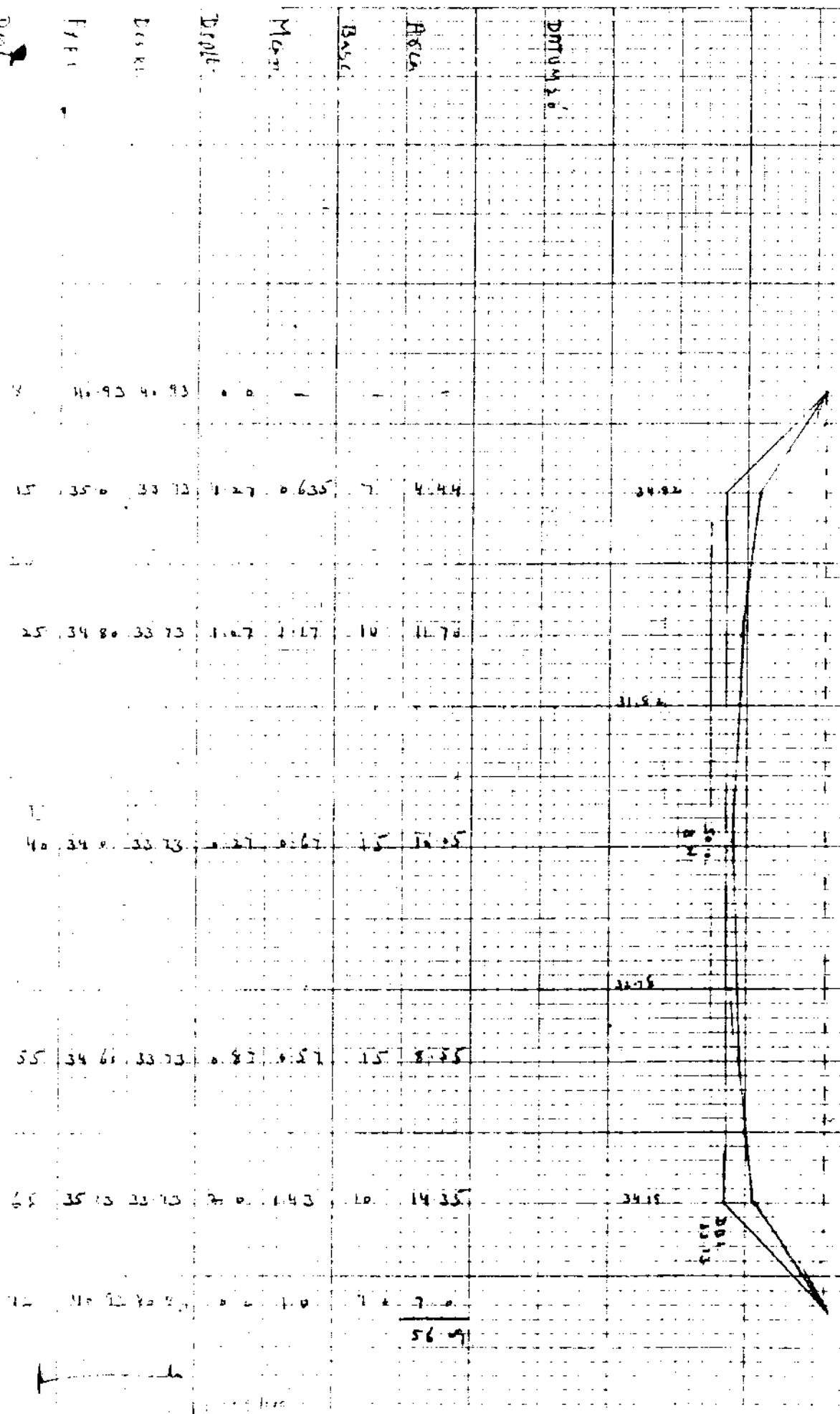

Dist

File

Dist

Dist

Dist

Dist

Dist

Dist

Dist

Dist

Dist

Dist

Dist

Dist

Dist

CENTRAL

AREA

BASE

MEAN DEPTH

WIDTH

PROPOSED

EXISTING

DISTANCE

Station	Left	Right	Depth	Area	Base	Depth	Distance
0	40.40	40.20	0.0				
15	35.50	33.47	2.03	1.015	7	7.10	
25	34.50	33.47	1.03	1.53	10	15.30	
40	34.10	33.47	0.63	0.83	15	12.45	
55	34.80	33.47	1.33	0.98	15	14.70	
65	38.00	33.47	2.53	1.93	10	19.30	
71	40.20	40.20	0.0	1.265	6		

75.9
76.44

30.22

30.19

30.20

24.47

EST. 40.26

R.D. 1940

DATUMLINE 20'

AREA

BASE

MEAN DEPTH

DEPTH

PROPOSED

EXISTING

DISTANCE

Station	Dist. to	Base	Height	Angle	Dist. to	Dist. to
9	39.51	39.51	0.0			
15	36.0	33.14	2.86	1.43	6	8.38
20	34.14	33.14	1.0	1.93	5	9.75
35	34.14	33.14	1.0	1.0	15	15.0
40	33.14	33.14	0.0	0.28	5	2.5
55	35.0	33.14	1.86	0.58	15	7.50
70	36.0	33.14	2.86	1.43	10	10.0
71	35.51	35.51	0.0	1.43	6	8.38

X- SECTION
GUN'S
BAR
BAR

R.D. 15 + D

39.51

S.P.W.

S.P.W.

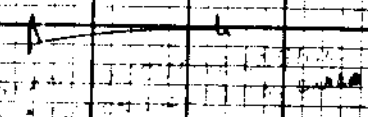

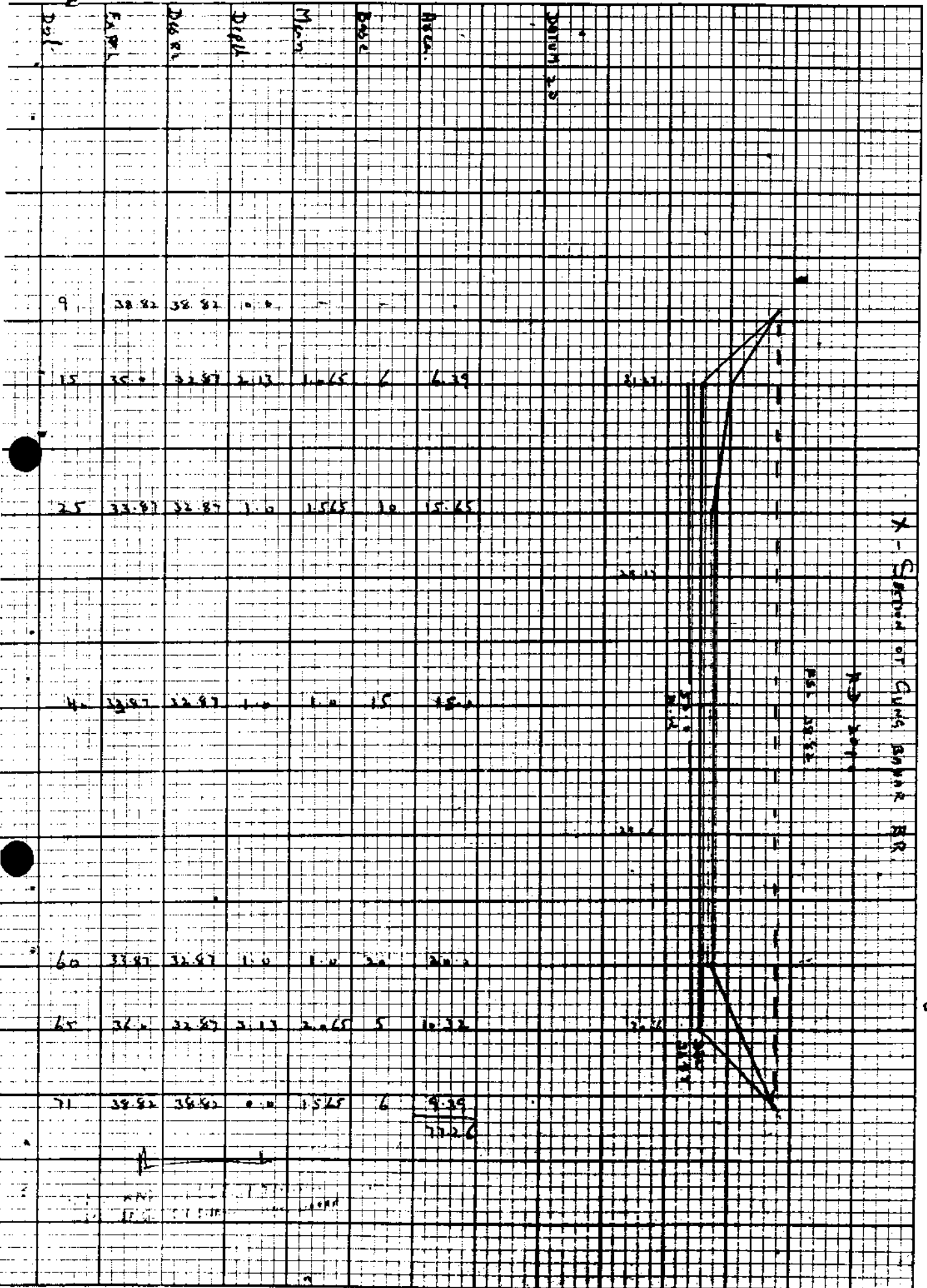

6-5



NYREX®

Depth	ASIA	B&L	M&A	Depth	D&R	F&R	D-1
9	19.65	7	1.23	0.0	32.54	38.08	9
25	19.65	10	1.96	1.23	32.54	38.08	25
35	19.65	15	1.23	1.0	32.54	38.08	35
50	19.65	15	1.23	1.47	32.54	38.08	50
60	19.65	10	1.96	2.46	32.54	38.08	60
86	19.65	6	1.23	0.0	32.54	38.08	86
	7.38						
	88.76						

X- SECTION OF GUNDS EMPIR BR:

R.D. 25.00

R.D. 38.19

28.02
50.4
28.02

28.02

31.82

31.82

27.02

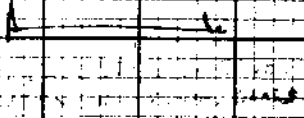

DEPTH	TRUTH	APPEAR.	DIFF.	REFR.	INDEX	TEMP.	DEPTH
0	37.73	37.33	0.0	-	-	-	
5	35.0	32.21	2.79	1.395	5	6.97	30.11
15	32.5	32.21	1.29	0.64	10	20.40	
25	32.0	32.21	0.59	0.94	10	9.40	35.51
40	33.0	32.21	1.29	0.94	20	18.80	36.5
50	34.0	32.21	1.79	0.94	10	15.40	37.0
55	37.73	37.33	0.0	0.995	5	6.47	38.1
						73.44	

X-SECTION OF QUINCY BR

RD 3070

PS 2000

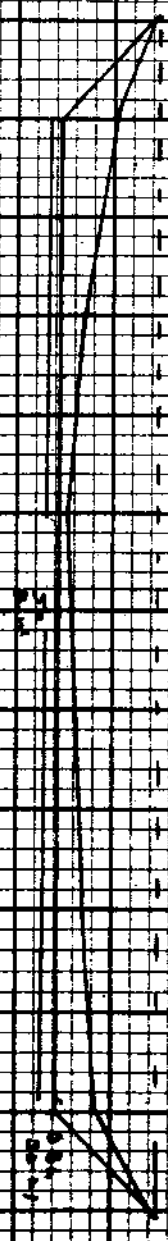

$1 - \frac{1}{1000} = 0.999$
 $1 - \frac{1}{1000} = 0.999$

Dist	Earl	Dist	Depth	Mean	Base	Area	Volume
0	36.57	36.57	0.0				
5	35.0	31.86	3.14	1.57	5	7.85	
10	33.0	31.86	1.14	2.14	5	10.70	
20	32.86	31.86	1.0	1.07	10	10.70	
30	32.5	31.86	0.64	0.82	10	8.20	
45	33.10	31.86	1.24	0.94	15	14.10	
55	34.0	31.86	2.14	1.69	10	16.90	
60	36.57	36.57	0.0	1.07	5	5.35	
							73.80

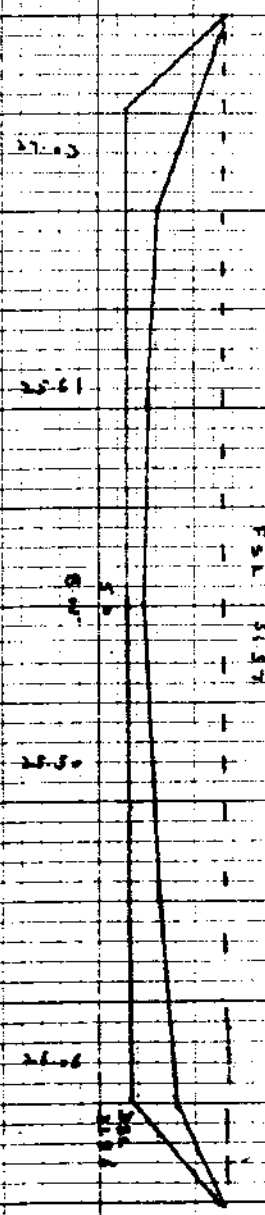

R.D. 35.10

F.S.L. 31.86

DATE: _____
 DRAWN BY: _____
 CHECKED BY: _____

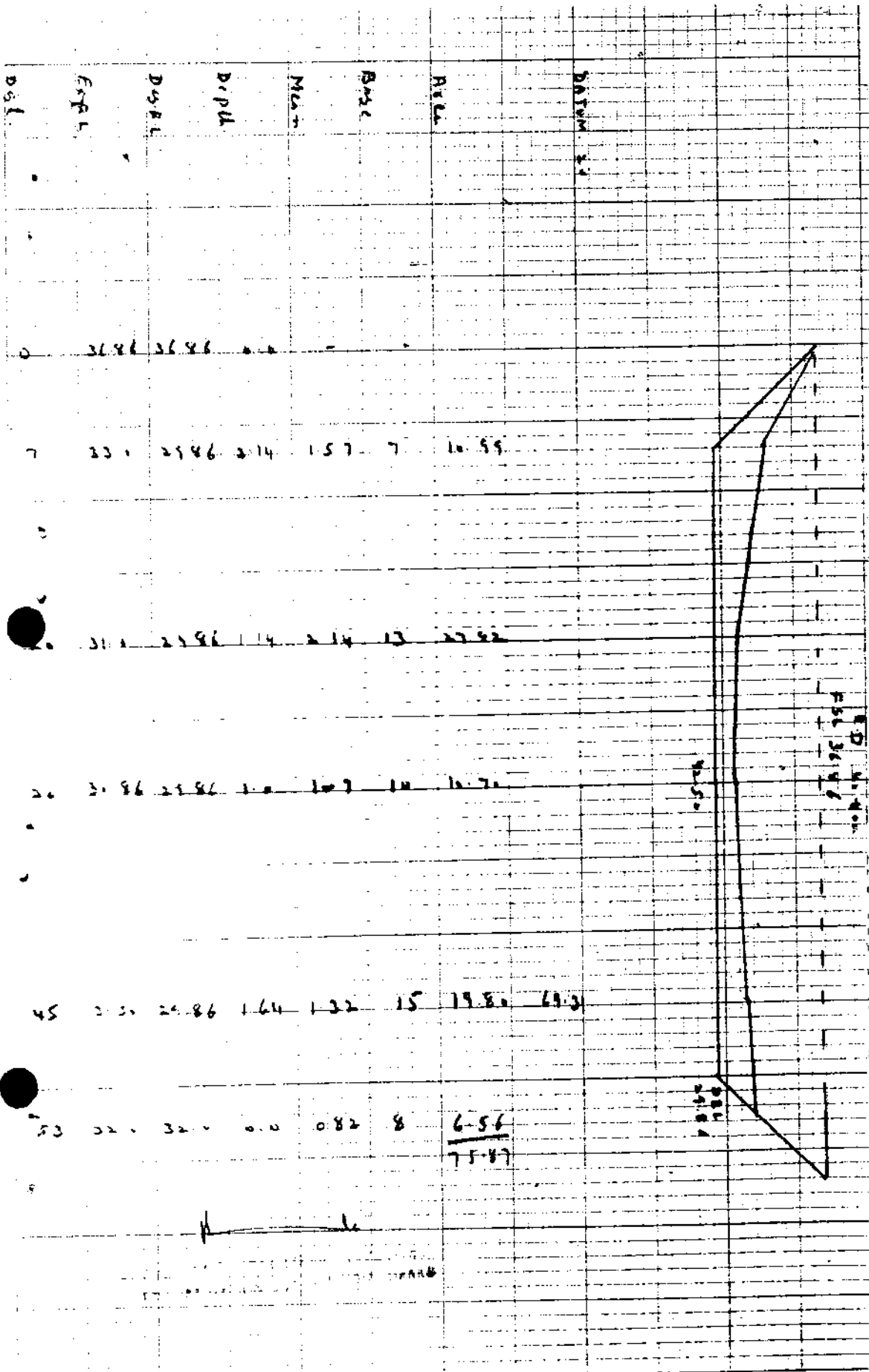

Profile
Datum 2.1

2.5

2.5

6.56
7.57

Profile

DRAW

X - SECTION OF QUAD BAHAR
R.D. 4574

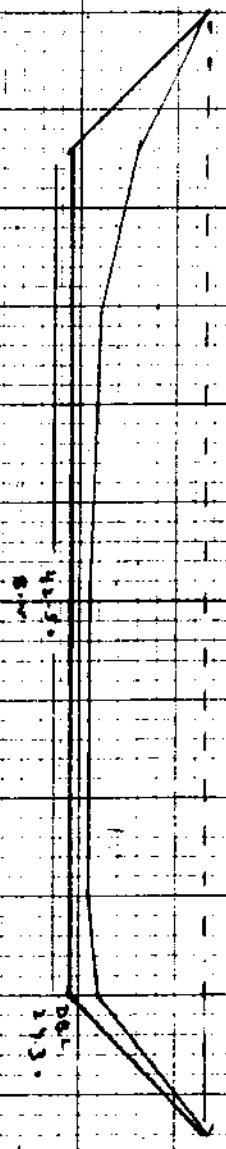

Dist.	Left	Right	Depth	Mean	Base	Area	Datum
0	36.30	36.30	0.00	0.00	0.00		20
7	33.00	29.50	3.70	1.85	7	12.95	
15	31.00	29.30	1.70	2.25	8	21.60	
23	30.30	29.30	1.00	1.50	15	20.25	
30	30.30	29.30	1.00	1.00	15	15.00	
38	31.00	29.30	1.70	1.35	5	6.75	
45	36.30	36.30	0.00	0.85	7	5.95	
						<u>82.50</u>	

X-SECTION GANJ BAHAR BRANCH EX-P.F.L RD 0+000

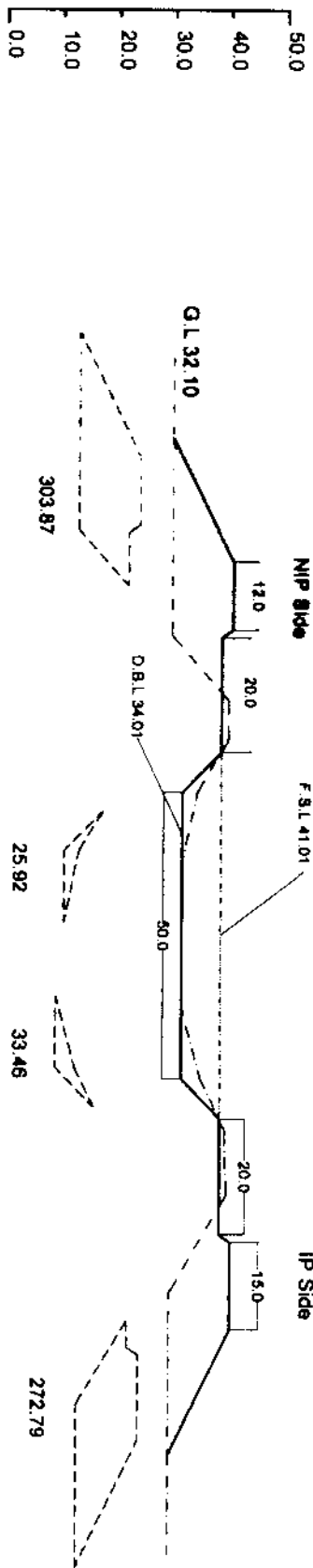

Design R.L	Existing R.L	Distance	Design R.L
	32.10	-101.38	
32.10	32.10	-87.15	32.10
43.01		-65.33	43.01
43.01		-53.33	43.01
41.01	32.10	-52.00	41.01
41.01	42.21	-41.12	41.01
41.01	42.28	-34.10	41.01
34.01	36.68	-25.00	34.01
34.01	34.01	-12.50	34.01
34.01	34.01	0.00	34.01
34.01	34.01	12.50	34.01
34.01	37.47	25.00	34.01
41.01	41.92	33.97	41.01
41.01	42.23	45.23	41.01
43.01		52.00	43.01
43.01	32.10	53.33	43.01
43.01		68.33	43.01
32.10	32.10	90.15	32.10
32.10	32.10	107.49	32.10

SUB ENGINEER

Assistant Executive Engineer
Darro Sub Division

Executive Engineer
Upper Pinyan Division
Hyderabad

X-SECTION GANJ BAHAR BRANCH EX-P.F.L RD 48+000

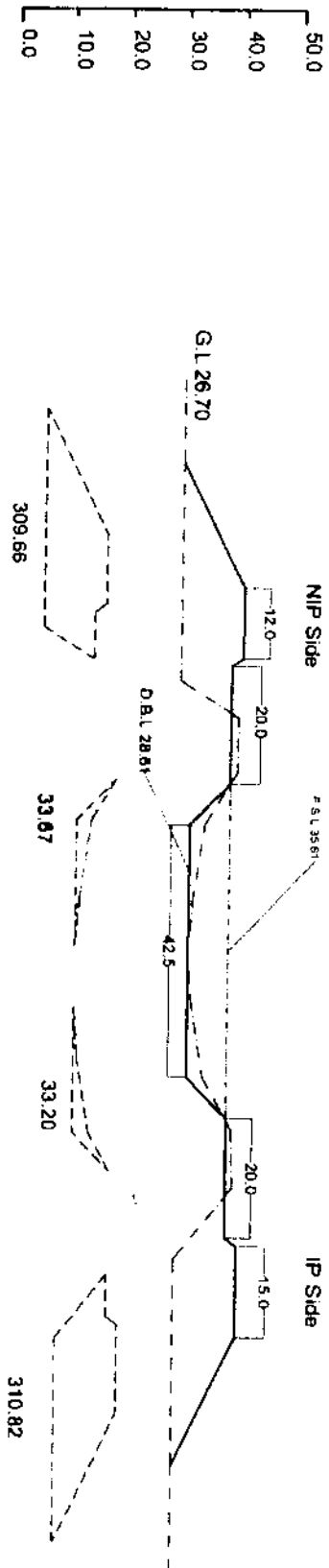

Design R.L	Existing R.L	Distance	Distance
	26.70	-97.63	
26.70	26.70	-83.40	
37.61		-61.58	
37.61		-49.58	
35.61		-48.25	
35.61	26.70	-45.76	
35.61	36.83	-39.56	
35.61	36.88	-30.35	
28.61	31.28	-21.25	
28.61	29.34	-8.75	
28.61	28.61	0.00	
28.61	29.25	8.75	
28.61	31.38	21.25	
35.61	36.52	30.22	
35.61	36.79	39.96	
37.61		48.25	
37.61	26.70	51.80	
37.61		64.58	
26.70	26.70	86.40	
26.70	26.70	103.74	

SUB ENGINEER

Assistant Executive Engineer
Datta Kudo (Hydrabad)

Executive Engineer
Upper Pinyari Division
Hydrabad

X-SECTION GANJ BAHAR BRANCH EX-P.F.L RD 70+000

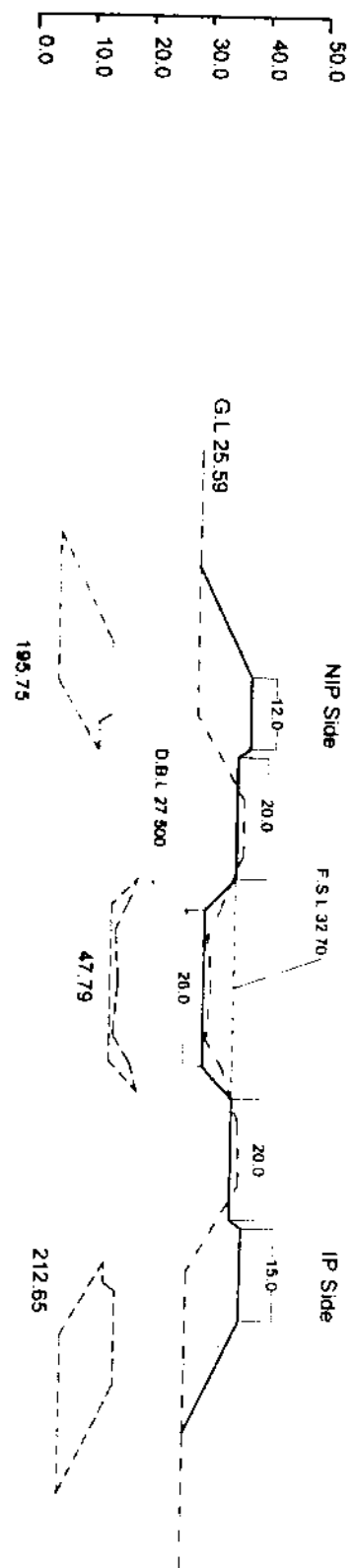

Design R.L	Existing R.L	Distance	Design R.L	Existing R.L	Distance
25.59	25.59	-89.38	25.59	25.59	-69.75
34.70	25.59	-45.21	34.70	25.59	-51.53
32.70	33.86	-31.31	32.70	-38.20	-39.53
27.50	33.94	-22.10	27.50	-13.00	-18.20
27.50	30.17	-13.00	27.50	-8.75	-13.00
32.70	28.23	0.03	32.70	0.00	0.00
34.70	28.83	8.75	34.70	13.00	13.00
34.70	28.14	13.07	34.70	18.20	18.20
34.70	30.88	21.97	34.70	38.20	38.20
34.70	33.84	32.57	34.70	39.53	39.53
34.70	34.07	46.58	34.70	54.53	54.53
25.59	25.59	72.75	25.59	72.75	72.75
25.59	25.59	95.49	25.59	25.59	25.59

SUB ENGINEER

Assistant Executive Engineer
Darro Sub Division

Executive Engineer
Upper Pinyari Division
Hyderabad

SCHEDULE OF PRICES – SUMMARY OF BID PRICES (Sample)

Bill No.	Description	Total Amount (Rs)
(A) Building Work		
1.	Civil works	
2.	Internal sanitary and water supply	
3.	Electrification	
4.	External Development works	
5.	Miscellaneous Items	
(B) Road Work.		
1.	Earthwork	
2.	Hard Crust and Surface Treatment	
3.	Culverts and Bridges	
4.	Miscellaneous Items	
(C) Public Health Engineering Works.		
1.	Earthwork	
2.	Subsurface Drains	
3.	Pipe Laying and Man holes	
4.	Tube wells, Pump houses	
5.	Compound wall	
6.	Miscellaneous Items	
Total Bid Price (The amount to be entered in Paragraph 7 of the Form of Bid) (In words).		

SCHEDULE OF PRICES

Item No.	Description	Quantity	Unit Rate(Rs)	Total Amount (Rs)
1.	I. (Civil works)			
2.				
3.				
1.	II. Internal sanitary and water supply.			
2.				
3.				
1.	III. Electrification.			
2.				
3.				
1.	IV. External Development works.			
2.				
3.				
1.	V. Miscellaneous Items			
2.				
3.				
Total (to be carried to Summary of Bid Price) Add/ Deduct the percentage quoted above/below on the prices of items based on Composite Schedule of Rates.				

Schedule "B"

NAME OF WORK REHABILITATION OF LAIKPUR EX: ALI BAHAR, REPAIR OF HEAD GROUP REGULATOR, PROVIDING STONE PITCHING ALONG GHARI WAH EX: PINYARI BRANCH RD. 4 TO 6 AND CATTLE RAMP RD. 6.

Quantity	item	Rate	Per	Amount
2569000.00 Sft.	1. Jungle clearance and removing within 100 ft (a) Light [S.Item No.04(a), P-No.100]	75.63	%o Sft.	194,293.47
802892.50 Acres	2. Earth work excavation in Irrigation channel drains etc dressed to design section grades and profiles excavated material disposed of and dressed within 50 ft lead (a) Ordinary soil [S.Item No.5(a) P.No.4]	2420	%o Cft.	1,942,999.85
1703500.00 Cft.	3. Borrowpit excavation undressed lead Upto 100 ft (a) Ordinary soil. [S.Item No.3(a) P.No.1]	2117.5	%o Cft.	3607161.25
2506392.50 Cft.	5. Rehandeling of earth work (b) up to lead of 50 ft lead [S.Item No.9(b) P.No.2]	1058.75	%o Cft.	2,653,643.06
935925.00 Cft.	6. Carriage of 100 Cft/5 ton of all materail like stone aggregate, spawal, coal lime surkhi etc. B.G.Rail fastening joints and crossing bridges girders pipe sheet rail MS bars etc or 1000 Nos bricks 10"x3"x3" or 1000 Nos tiles 12"x6"x2" or 150 cft timber or 1000 Nos maund or fuel wood by trolly or any other means owned by contractors 2 Miles [S.Item No.1, P.No.1 Sch. Carriage]	407.00	% Cft	3,813,284.74
2506392.50 Cft	7. Earth work compection (Soft ordinary or hard soil) (a) lying earth 6' layer leveling and dressig complete [S.Item No.13(a) P.No.3]	263	%o Cft	659,181.23
Total Rs.				12,870,563.60

Part B

Quantity	item	Rate	Per	Amount
832.16 Cft.	1. Dismantling cement concrete reinforced separating reinforcement from concrete cleaning and strengthening the same [S.Item No.20 P.No.10]	5445.00	% Cft	34,421.11
2306.73 Cft.	2. Dismantling brick work in lime or cement mortar. [S.Item No.13 P.No.10]	1285.63	% Cft	36,084.16
7520.00 Cft.	3. Excavation in foundation of buildings bridges and other structure i/c dag-belling dressing, refilling around structure with excavated earth watering and ramming lead upto one chain and lift upto 5 feet. (b) Ordinary Soil. [S.Item No.18(b) P.No.06]	1306.80	% Cft.	9,827.14
1504.00 Cft.	4. Cement concrete plain i/c placing, compacting, finishing and curing complete (i/c screening and washing of stone aggregate without shuttering). (f) Ratio 1:3:6	12595.00	% Cft	189,428.80
1115.65 Cft.	(h) Ratio 12:4 [S.Item No.5(f)(h) P.No.18]	14429.25	% Cft	160,979.93
3534.88 Cft.	5. Pacca brick work in foundation and plinth in: (i) (d) Cement sand mortar 1:5 [S.Item No.7(i)(d), P.No.22-21]	12176.08	% Cft	436,497.86
6746.59 Cft.	6. Pacca brick work other than building. i/c striking of joints upto 20' height in: (i) (d) Cement sand mortar 1:5 [S.Item No.7(i)(d), P.No.20]	12574.38	% Cft	848,341.86
				1,715,580.86

Quantity	item	Rate	Per	Amount
				1,715,580.86
632.16 Cft	7. Reinforced cement concrete work i/c all labour and material except the cost of steel reinforcement and its labour for bending and brinding which will paid separately. The rate also includes all kinds of forms moulds lifting shuttering curing rendering and finishing the exposed surface (i/c screening and washing of shingle). (a) R.C.C.work in roof slab beams columnis rafts lintels and other structural members laid in situ or precast laid in position completed in all respects. (i) Ratio (1:2:4) 90lbs cement 2 Cft sand 4 Cft shingle 1/8" to 1/4" gauge. [S.Item No.6(a)(i), P.No.17]	337.00	P.Cft	213,037.92
39.51 Cwt	8. (a) Fabrication of mild stell reinforceemnt for cement concrete i/c cutting,, bending, laying in position making joints and fastenings i/c cost of binding wire (also includes removal of rust from bars) [S.Item No.8(a), P.No.17]	4820.20	P.Cwt	190,446.10
2738.92 Sft.	9. Cement Plaster 1:2 20' height (c) 3/4" thick [S.Item No.9(c) P.No.52]	3056.62	%o Sft.	85,246.69
				<u>2,204,311.57</u>

Part C

Quantity	item	Rate	Per	Amount
11083.50 Cft	1. Excavation in foundtaion of buildings bridges and other structure i/c dag-belling dressing, refilling around structure with excavated earth watering and ramming lead upto one chain and lift upto 5 feet. (b) Ordinary Soil. [S.Item No.18(b) P.No.04]	3176.25	%o Cft.	35,203.97

Quantity	item	Rate	Per	Amount
3325 Cft.	2. Extra for slush or daldal i/c dewatering [S.Item No.16, P.No.04]	2420.00	%o Cft.	8,046.50
9852.00 Cft.	3. Stone filling dry hand packed as filling behind walls or in pitching and apron. [S.Item No.16, P.No.31]	2684.00	% Cft	264,427.68
14974.98 Sft.	4. Formation dressing and preparing sub-grade (a) slope [S.Item No.1(b) P.No.74]	453.75	% Sft	67,948.97
27688.46 Cft.	5. Stone Pitching i/c sub-base with hammer dressed stone on surface laid in courses i/c carriage of material within 3 chains [S.Item No.23, P.No.32]	5377.63	% Cft	1,488,982.93
183772.64 Cft.	6. Borrowpit excavation undressed lead Upto 100 ft (a) Ordinary soil. (a) Ordinary Soil. [S.Item No.19(a) P.No.18]	2117.50	%o Cft.	389,138.57
111920.00 Cft.	7. Carriage of 100 Cft/5 ton of all material like stone aggregate, spawal, coal lime surkhi etc. B.G.Rail fastening joints and crossing bridges girders pipe sheet rail MS bars etc or 1000 Nos bricks 10"x3"x3" or 1000 Nos tiles 12"x6"x2" or 150 cft timber or 1000 Nos maund or fuel wood by trolley or any other means owned by contractors 3 Miles [S.Item No.1, P.No.1 Sch. Carriage]	407.00	% Cft	455,514.39
				2,709,263.01

Quantity	item	Rate	Per	Amount
183772.64 Cft.	8. Earth work compection (Soft, Ordinary, Hard Soil) (a) lying earth 6' layer leveling and dressing complete [S.Item No.13(a) P.No.3]	263.00	%o Cft.	48,332.20
Total Rs.				<u>2,757,595.21</u>

A=	12,870,563.60
B=	2,204,311.57
C=	<u>2,757,595.21</u>
G. Total.	<u>17,832,470.38</u>

NB: No above premium is allowed to item No. 6 of part A and item No. 7 of part C.

Contractor

Executive Engineer
Upper Pinyari Division
Hyderabad

SCHEDULE - B TO BID

***SPECIFIC WORKS DATA**

(To be prepared and incorporated by the Procuring Agency)

**(Note: The Procuring Agency shall spell out the information & data required to be filled out by the bidder and to furnish complementary information).*

SCHEDULE – C TO BID

WORKS TO BE PERFORMED BY SUBCONTRACTORS*

The bidder will do the work with his own forces except the work listed below which he intends to sub-contract.

Items of Works to be Sub-Contracted	Name and address of Sub-Contractors	Statement of similar works previously executed. (attach evidence)
-------------------------------------	-------------------------------------	-------------------------------------------------------------------

Note:

- * *The Procuring Agency should decide whether to allow subcontracting or not. In case Procuring Agency decides to allow subcontracting then following conditions shall be complied with:*
 1. No change of Sub-Contractors shall be made by the bidder without prior approval of the Procuring Agency.
 2. The truthfulness and accuracy of the statement as to the experience of Sub-Contractors is guaranteed by the bidder. The Procuring Agency's judgment shall be final as to the evaluation of the experience of Sub-Contractors submitted by the bidder.
 3. Statement of similar works shall include description, location & value of works, year completed and name & address of the clients.

SCHEDULE - D TO BID

PROPOSED PROGRAMME OF WORKS

Bidder shall provide a programme in a bar-chart or Program Evaluation and Review Technique (PERT) or Critical Path Method (CPM) showing the sequence of work items by which he proposes to complete the works of the entire Contract. The programme should indicate the sequence of work items and the period of time during which he proposes to complete the works including the activities like designing, schedule of submittal of drawings, ordering and procurement of materials, manufacturing, delivering, construction of civil works, erection, testing and commissioning of works to be supplied under the Contract.

SCHEDULE - E TO BID

METHOD OF PERFORMING WORKS

The bidder is required to submit a narrative outlining the method of performing the Works. The narrative should indicate in detail and include but not be limited to:

- The sequence and methods in which he proposes to carry out the Works, including the number of shifts per day and hours per shift, he expects to work.
- A list of all major items of construction and plant erection, tools and vehicles proposed to be used in delivering/carrying out the works at site.
- The procedure for installation of equipment and transportation of equipment and materials to the site.
- Organisation chart indicating head office & field office personnel involved in management, supervision and engineering of the Works to be done under the Contract.

(INTEGRITY PACT)

DECLARATION OF FEES, COMMISSION AND BROKERAGE ETC
PAYABLE BY CONTRACTORS
(FOR CONTRACTS WORTH RS. 10.00 MILLION OR MORE)

Contract No. _____ Dated _____
Contract Value: _____
Contract Title: _____

..... [name of Contractor] hereby declares that it has not obtained or induced the procurement of any contract, right, interest, privilege or other obligation or benefit from Government of Sindh (GoS) or any administrative subdivision or agency thereof or any other entity owned or controlled by it (GoS) through any corrupt business practice.

Without limiting the generality of the foregoing, [name of Contractor] represents and warrants that it has fully declared the brokerage, commission, fees etc, paid or payable to anyone and not given or agreed to give and shall not give or agree to give to anyone within or outside Pakistan either directly or indirectly through any natural or juridical person, including its affiliate, agent, associate, broker, consultant, director, promoter, shareholder, sponsor or subsidiary, any commission, gratification, bribe, finder's fee or kickback, whether described as consultation fee or otherwise, with the object of obtaining or inducing the procurement of a contract, right, interest, privilege or other obligation or benefit in whatsoever form from, from Procuring Agency (PA) except that which has been expressly declared pursuant hereto.

[name of Contractor] accepts full responsibility and strict liability that it has made and will make full disclosure of all agreements and arrangements with all persons in respect of or related to the transaction with PA and has not taken any action or will not take any action to circumvent the above declaration, representation or warranty.

[name of Contractor] accepts full responsibility and strict liability for making any false declaration, not making full disclosure, misrepresenting facts or taking any action likely to defeat the purpose of this declaration, representation and warranty. It agrees that any contract, right, interest, privilege or other obligation or benefit obtained or procured as aforesaid shall, without prejudice to any other rights and remedies available to PA under any law, contract or other instrument, be voidable at the option of PA.

Notwithstanding any rights and remedies exercised by PA in this regard, [name of Supplier/Contractor/Consultant] agrees to indemnify PA for any loss or damage incurred by it on account of its corrupt business practices and further pay compensation to PA in an amount equivalent to ten time the sum of any commission, gratification, bribe, finder's fee or kickback given by [name of Contractor] as aforesaid for the purpose of obtaining or inducing the procurement of any contract, right, interest, privilege or other obligation or benefit in whatsoever form from PA.

.....
[Procuring Agency]

.....
[Contractor]

***DRAWINGS**

**(Note: The Engineer/Procuring Agency may incorporate specific Drawings for Bidding purposes only or may include the detailed drawings in a separate volume, if necessary).*

HEAD REGULAT Ex ALI BAHAR

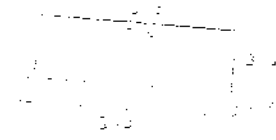
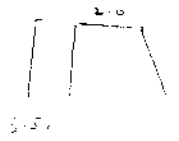
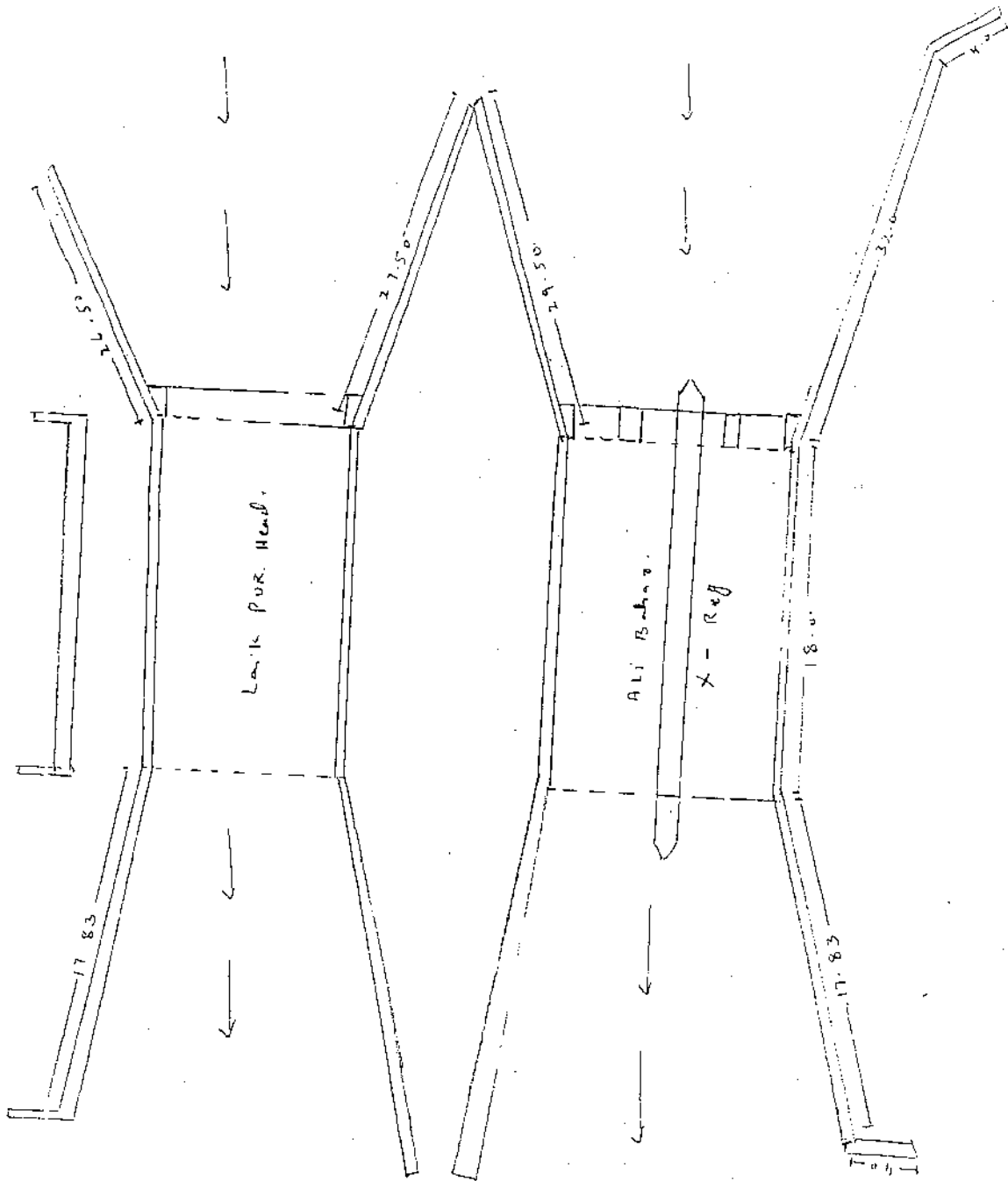

ESTIMATE FOR PROVIDING STONE PITCHING ALONG GHARI WAH EX-PINYARI BR. RD 4 TO 6.
WITH CATTLE RAMP AT RD 6.

Measuremnt Sheet

S.No.	Item of work	No	Length	Berth	Depth	Quantity
1. Excavation in foundation of buildings, bridges and other structure i/c dag:						
	Toe wali Ghari wah RD 4 to 6	2	x 821	x $\frac{3.00 + 3.00}{2}$	x $\frac{2.00 + 2.50}{2}$	= 11083.50 Cft
2. Extra for slush or daldal i/c dewatering.						
				30% Qty of Item No1 Below Bed Level		3325.05 Cft
4. Stone filling dry hand packed as filling behind retaining walls or pitching and						
	Toe wall	2	x 821	x 3.00	x 2.00	= 9852 Cft
5. Formation and dressing and preparing sub-grade						
	Stone Pitching	2	x 821	x 7.92		= 13003.98 Sft.
	Cattle Ramp	1	x 100	x 19.71		= 1971.00 Sft.
				Total Quantity		14974.98 Sft.
6. Stone Pitching i/c sub-base with hammer dressed stone on surface laid in courses						
	Stone Pitching	2	x 821	x 9.92	x 1.5	= 24431.96 Cft
	Cattle Ramp	1	x 100	x 21.71	x 1.5	= 3255.50 Cft
				Total Quantity		27688.46 Cft
7. Borrowpit excavation undressed lead upto 100 ft.						
	Filling on banks/stone Pitching	1	x 821	x 223.84		= 183773 Cft
				As Per -Sec attached.		
8. Carriage of 100 Cft/5 ton of all material like Stone aggregate, spawal, coal lime surkhi etc						
				50 % Qty as item No.7 above.		= 111920 Cft
9. Earth work compection (Soft Ordinary, Hard Soil) (a) lying earth 6' layer leveling and dressing complete						
				Quantity same as item No.7 above.		= 183773 Cft

Assistant Executive Engineer
Public Works Division

CARTAGE STATEMENT

ESTIMATE FOR PROVIDING STONE PITCHING ALONG GHARI WAH EX-PINYARI BR. RD 4 TO 6.

S. No	item	Quantity	Cement	Sand	Bajri	S/Aggregate	Stone
	Stone Filling dry hand packed	9852.00 Cft.					13300.20
2	Stone Pitching Sub-Base	27688.46 Cft.			6922.12	6922.12	16613.08

Total	0.00	0.00	6922.12	6922.12	6922.12	29913.28
Source	Thatta	Ghaghar	Makali	Makli	Chillya	
Lead in Miles	85	65	40	40	60	
Rate in Rs.	57.33	2693.00	1879.00	1879.00	2530.20	
Total	0	0	130066.56	130066.5635	756865.7826	
					1,016,998.91	

 Assistant Executive Engineer
 Darro Sub-Division

TYPICAL X-SECTION OF GHARI WAH EX-PINYARI BRANCH AT RD 5+000

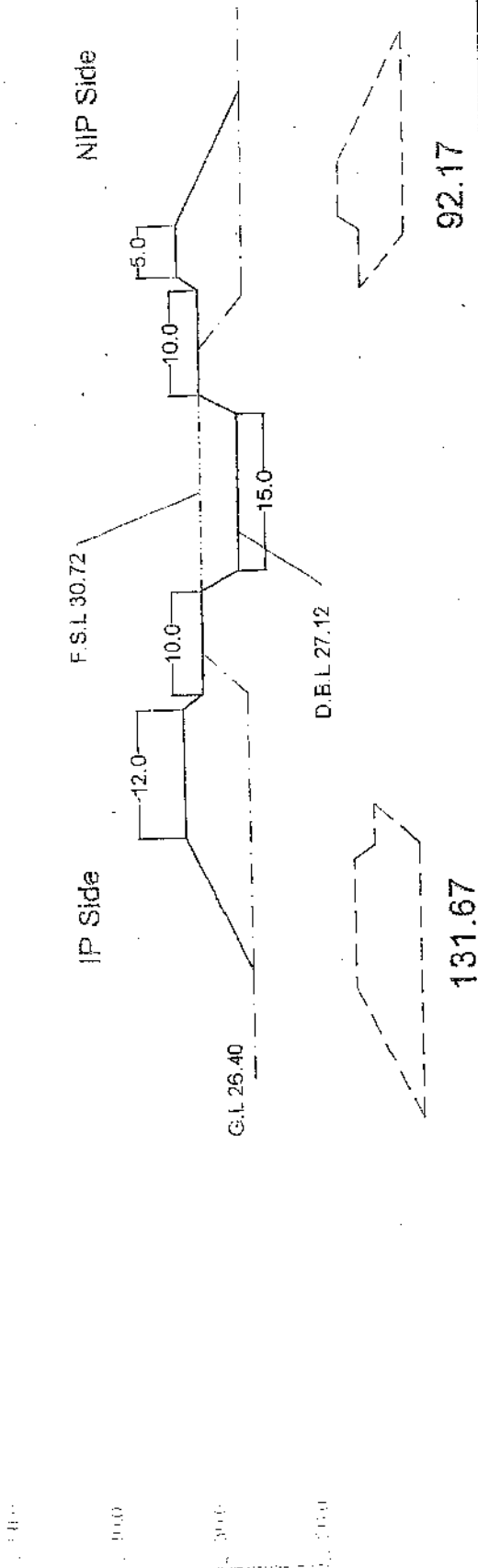

92.17

131.67

Height (ft)	26.40	32.72	30.72	27.12	27.12	30.72	27.12	27.12	30.72	26.40	26.40	26.40	38.27	26.40	26.40	46.28
Width (ft)	-45.27	-32.63	-20.63	-9.30	-9.30	-19.30	-9.30	0.00	9.30	30.72	30.72	30.72	25.63	19.30	26.40	38.27
Depth (ft)	26.40	26.40	26.40	30.72	30.72	30.72	30.72	30.72	30.72	30.72	30.72	30.72	30.72	30.72	30.72	30.72
Area (sq ft)	-55.57	-45.27	-19.17	-15.36	-9.30	-7.50	0.00	7.50	9.30	13.59	18.75	25.63	32.72	38.27	46.28	

Signature
Executive Engineer
Upper Pinyari Division
Hyderabad

Assistant Executive Engineer
Darro Sub Division

SUB ENGINEER

SECTION OF STONE PITCHING AND CATTLE RAMP ALONG GHARI WAH FX-PINYARI

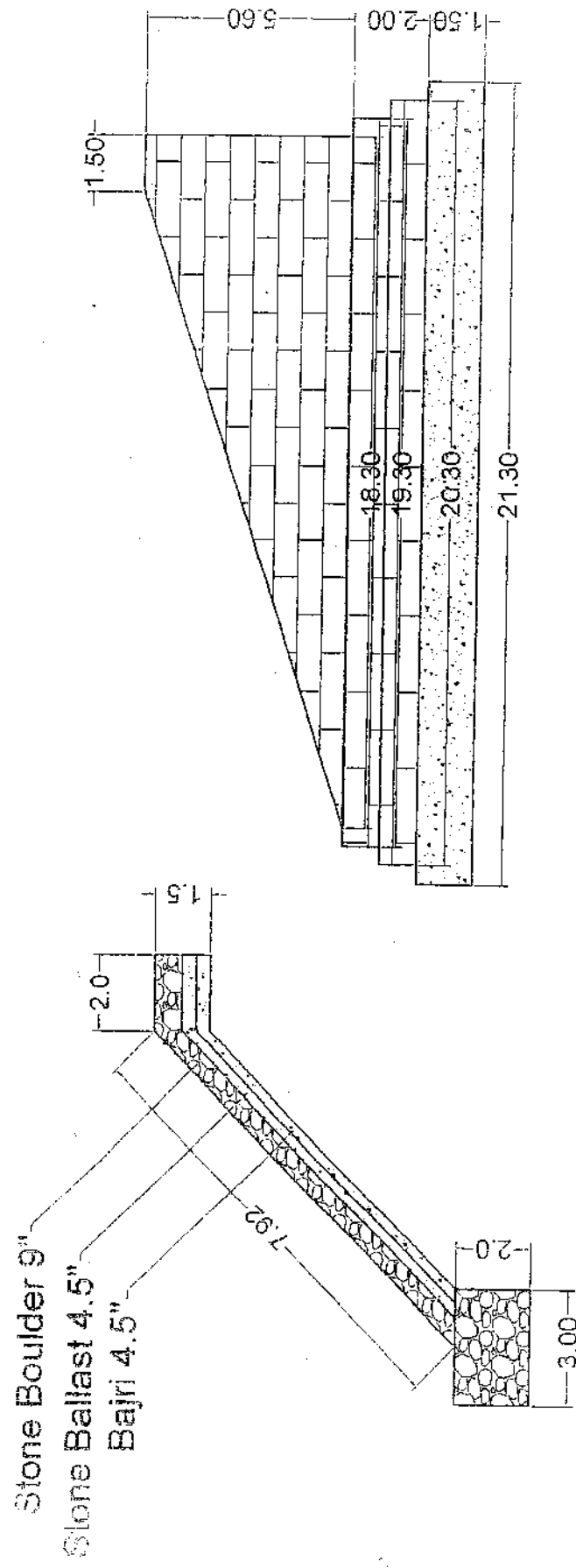

Stone Pitching

Cattle Ramp

SUB ENGINEER

ASSISTANT EXECUTIVE ENGINEER
DARRO SUB DIVISION

[Signature]
EXECUTIVE ENGINEER
UPPER PINYARI DIVISION
NADERABAD

L - Section of LATH PBR Ex ALLI Bldg.

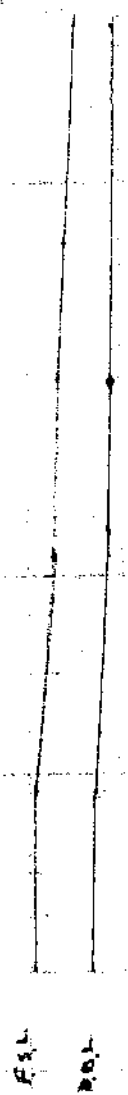

Dist.	DBL	FSL	FSD	DBL W	DEPTH	Bot	Exl
0	36.83	37.93	37.14	11.50			
1	36.88	39.78	37.10	11.50			
2	36.92	39.62	37.10	11.50			
3	36.97	39.47	37.10	11.50			
4	36.22	39.32	37.10	11.50			
5	36.47	39.17	37.10	11.50			
6	36.41	39.01	37.10	11.50			
7	35.95	38.85	37.10	10.50			
8	35.90	38.70	37.10	10.50			
9	35.73	38.53	37.10	10.00			
10	35.57	38.37	37.10	10.00			
11	35.41	38.21	37.10	10.00			
12	35.25	38.05	37.10	10.00			
13	35.38	37.88	37.10	9.00			
14	35.61	37.71	37.10	9.00			
15	35.22	37.52	37.10	9.00			
15.75	35.18	37.38	37.10	9.00			

SECTION OF LAKE FOR FILLING
R.D. 0+0

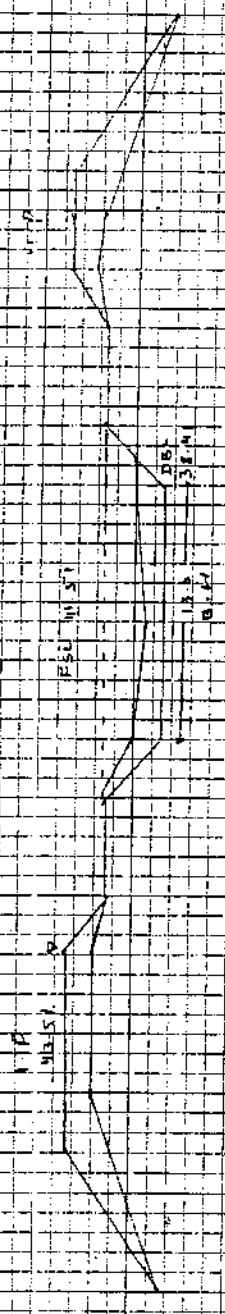

$$51.84 = 25.5 + 1.25 \times 2$$

51.84	25.5	1.25	2
-------	------	------	---

20.4	0.2	5.0	1.25	0.4	4.3
50.4	0.2	1.1	1.25	0.4	5.3
11.0	0.2	1.1	1.25	0.4	5.3
		0.2	1.25	1.25	0.4

19.4	0.2	1.1	1.25	0.4	5.3
11.0	0.2	1.1	1.25	0.4	5.3

11.0	0.2	1.1	1.25	0.4	5.3
------	-----	-----	------	-----	-----

50.4	0.2	1.1	1.25	0.4	5.3
25.5	0.2	1.1	1.25	0.4	5.3

19.4	0.2	1.1	1.25	0.4	5.3
11.0	0.2	1.1	1.25	0.4	5.3

50.4	0.2	1.1	1.25	0.4	5.3
11.0	0.2	1.1	1.25	0.4	5.3

25.5	0.2	1.1	1.25	0.4	5.3
------	-----	-----	------	-----	-----

Index No
Date
Page No
Title
Scale
Drawing
Name

SECTION OF LEAK FOR F/A
RD 5+0

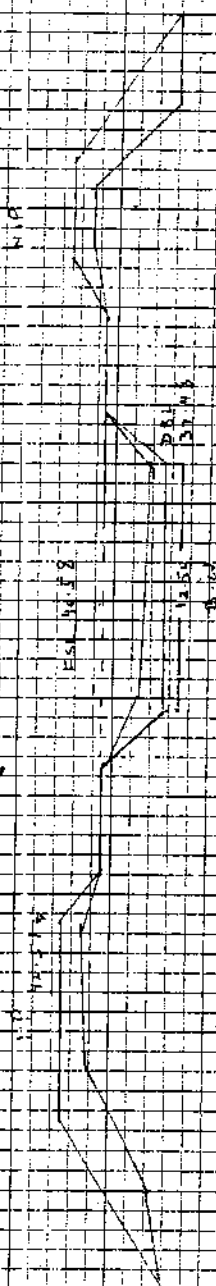

DATE

ASCE

BOOKY

MEAN

DATA

DISTRICT

ESTRIL

PLANNING

Station	Left	Right	Total
21.50	1.00	1.00	2.00
21.55	1.05	1.05	2.10
21.60	1.10	1.10	2.20
21.65	1.15	1.15	2.30
21.70	1.20	1.20	2.40
21.75	1.25	1.25	2.50
21.80	1.30	1.30	2.60
21.85	1.35	1.35	2.70
21.90	1.40	1.40	2.80
21.95	1.45	1.45	2.90
22.00	1.50	1.50	3.00

Name

To be reviewed together with other answers to paper

X- SECTION OF LINK PUR IF ALUMINUM

RD 040

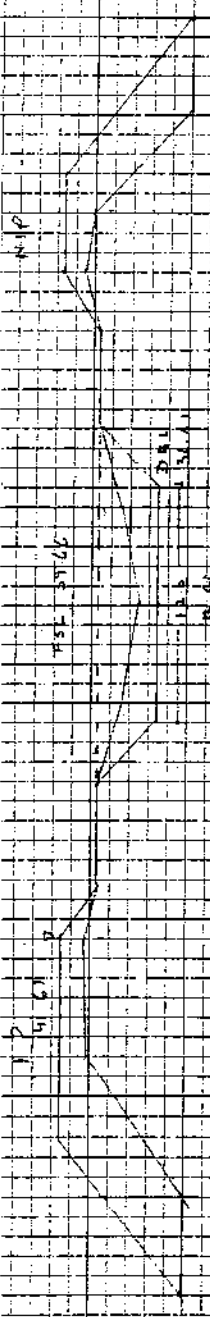

DEPTH	WIP	BASE	AREA	DIMENSION
1	0.00	0.00	0.00	0.00
2	0.00	0.00	0.00	0.00
3	0.00	0.00	0.00	0.00
4	0.00	0.00	0.00	0.00
5	0.00	0.00	0.00	0.00
6	0.00	0.00	0.00	0.00
7	0.00	0.00	0.00	0.00
8	0.00	0.00	0.00	0.00
9	0.00	0.00	0.00	0.00
10	0.00	0.00	0.00	0.00
11	0.00	0.00	0.00	0.00
12	0.00	0.00	0.00	0.00
13	0.00	0.00	0.00	0.00
14	0.00	0.00	0.00	0.00
15	0.00	0.00	0.00	0.00
16	0.00	0.00	0.00	0.00
17	0.00	0.00	0.00	0.00
18	0.00	0.00	0.00	0.00
19	0.00	0.00	0.00	0.00
20	0.00	0.00	0.00	0.00
21	0.00	0.00	0.00	0.00
22	0.00	0.00	0.00	0.00
23	0.00	0.00	0.00	0.00
24	0.00	0.00	0.00	0.00
25	0.00	0.00	0.00	0.00
26	0.00	0.00	0.00	0.00
27	0.00	0.00	0.00	0.00
28	0.00	0.00	0.00	0.00
29	0.00	0.00	0.00	0.00
30	0.00	0.00	0.00	0.00
31	0.00	0.00	0.00	0.00
32	0.00	0.00	0.00	0.00
33	0.00	0.00	0.00	0.00
34	0.00	0.00	0.00	0.00
35	0.00	0.00	0.00	0.00
36	0.00	0.00	0.00	0.00
37	0.00	0.00	0.00	0.00
38	0.00	0.00	0.00	0.00
39	0.00	0.00	0.00	0.00
40	0.00	0.00	0.00	0.00
41	0.00	0.00	0.00	0.00
42	0.00	0.00	0.00	0.00
43	0.00	0.00	0.00	0.00
44	0.00	0.00	0.00	0.00
45	0.00	0.00	0.00	0.00
46	0.00	0.00	0.00	0.00
47	0.00	0.00	0.00	0.00
48	0.00	0.00	0.00	0.00
49	0.00	0.00	0.00	0.00
50	0.00	0.00	0.00	0.00
51	0.00	0.00	0.00	0.00
52	0.00	0.00	0.00	0.00
53	0.00	0.00	0.00	0.00
54	0.00	0.00	0.00	0.00
55	0.00	0.00	0.00	0.00
56	0.00	0.00	0.00	0.00
57	0.00	0.00	0.00	0.00
58	0.00	0.00	0.00	0.00
59	0.00	0.00	0.00	0.00
60	0.00	0.00	0.00	0.00
61	0.00	0.00	0.00	0.00
62	0.00	0.00	0.00	0.00
63	0.00	0.00	0.00	0.00
64	0.00	0.00	0.00	0.00
65	0.00	0.00	0.00	0.00
66	0.00	0.00	0.00	0.00
67	0.00	0.00	0.00	0.00
68	0.00	0.00	0.00	0.00
69	0.00	0.00	0.00	0.00
70	0.00	0.00	0.00	0.00
71	0.00	0.00	0.00	0.00
72	0.00	0.00	0.00	0.00
73	0.00	0.00	0.00	0.00
74	0.00	0.00	0.00	0.00
75	0.00	0.00	0.00	0.00
76	0.00	0.00	0.00	0.00
77	0.00	0.00	0.00	0.00
78	0.00	0.00	0.00	0.00
79	0.00	0.00	0.00	0.00
80	0.00	0.00	0.00	0.00
81	0.00	0.00	0.00	0.00
82	0.00	0.00	0.00	0.00
83	0.00	0.00	0.00	0.00
84	0.00	0.00	0.00	0.00
85	0.00	0.00	0.00	0.00
86	0.00	0.00	0.00	0.00
87	0.00	0.00	0.00	0.00
88	0.00	0.00	0.00	0.00
89	0.00	0.00	0.00	0.00
90	0.00	0.00	0.00	0.00
91	0.00	0.00	0.00	0.00
92	0.00	0.00	0.00	0.00
93	0.00	0.00	0.00	0.00
94	0.00	0.00	0.00	0.00
95	0.00	0.00	0.00	0.00
96	0.00	0.00	0.00	0.00
97	0.00	0.00	0.00	0.00
98	0.00	0.00	0.00	0.00
99	0.00	0.00	0.00	0.00
100	0.00	0.00	0.00	0.00

72 10 = 10.00

X SECTION OF LINE FOR FA ALL BAND
R 9 15+0

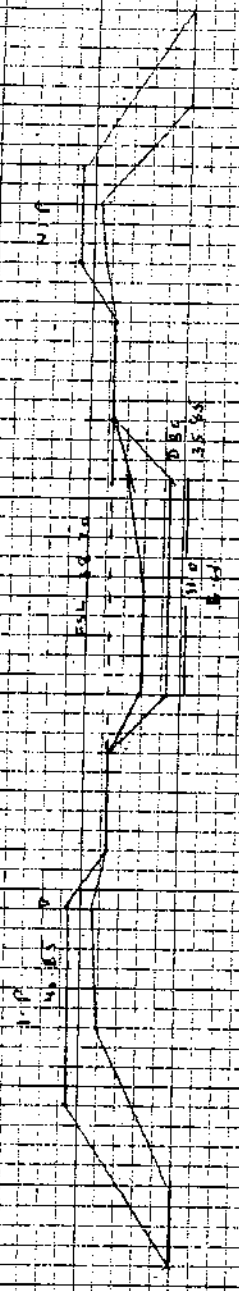

Station	Area	Base	Mean	Depth	Depth	Area	Distance
1	35.0	35.0	0.0	0.0	0.0	0.0	0.0
2	35.0	35.0	0.0	0.0	0.0	0.0	0.0
3	35.0	35.0	0.0	0.0	0.0	0.0	0.0
4	35.0	35.0	0.0	0.0	0.0	0.0	0.0
5	35.0	35.0	0.0	0.0	0.0	0.0	0.0
6	35.0	35.0	0.0	0.0	0.0	0.0	0.0
7	35.0	35.0	0.0	0.0	0.0	0.0	0.0
8	35.0	35.0	0.0	0.0	0.0	0.0	0.0
9	35.0	35.0	0.0	0.0	0.0	0.0	0.0
10	35.0	35.0	0.0	0.0	0.0	0.0	0.0
11	35.0	35.0	0.0	0.0	0.0	0.0	0.0
12	35.0	35.0	0.0	0.0	0.0	0.0	0.0
13	35.0	35.0	0.0	0.0	0.0	0.0	0.0
14	35.0	35.0	0.0	0.0	0.0	0.0	0.0
15	35.0	35.0	0.0	0.0	0.0	0.0	0.0
16	35.0	35.0	0.0	0.0	0.0	0.0	0.0
17	35.0	35.0	0.0	0.0	0.0	0.0	0.0
18	35.0	35.0	0.0	0.0	0.0	0.0	0.0
19	35.0	35.0	0.0	0.0	0.0	0.0	0.0
20	35.0	35.0	0.0	0.0	0.0	0.0	0.0
21	35.0	35.0	0.0	0.0	0.0	0.0	0.0
22	35.0	35.0	0.0	0.0	0.0	0.0	0.0
23	35.0	35.0	0.0	0.0	0.0	0.0	0.0
24	35.0	35.0	0.0	0.0	0.0	0.0	0.0
25	35.0	35.0	0.0	0.0	0.0	0.0	0.0
26	35.0	35.0	0.0	0.0	0.0	0.0	0.0
27	35.0	35.0	0.0	0.0	0.0	0.0	0.0
28	35.0	35.0	0.0	0.0	0.0	0.0	0.0
29	35.0	35.0	0.0	0.0	0.0	0.0	0.0
30	35.0	35.0	0.0	0.0	0.0	0.0	0.0
31	35.0	35.0	0.0	0.0	0.0	0.0	0.0
32	35.0	35.0	0.0	0.0	0.0	0.0	0.0
33	35.0	35.0	0.0	0.0	0.0	0.0	0.0
34	35.0	35.0	0.0	0.0	0.0	0.0	0.0
35	35.0	35.0	0.0	0.0	0.0	0.0	0.0
36	35.0	35.0	0.0	0.0	0.0	0.0	0.0
37	35.0	35.0	0.0	0.0	0.0	0.0	0.0
38	35.0	35.0	0.0	0.0	0.0	0.0	0.0
39	35.0	35.0	0.0	0.0	0.0	0.0	0.0
40	35.0	35.0	0.0	0.0	0.0	0.0	0.0
41	35.0	35.0	0.0	0.0	0.0	0.0	0.0
42	35.0	35.0	0.0	0.0	0.0	0.0	0.0
43	35.0	35.0	0.0	0.0	0.0	0.0	0.0
44	35.0	35.0	0.0	0.0	0.0	0.0	0.0
45	35.0	35.0	0.0	0.0	0.0	0.0	0.0
46	35.0	35.0	0.0	0.0	0.0	0.0	0.0
47	35.0	35.0	0.0	0.0	0.0	0.0	0.0
48	35.0	35.0	0.0	0.0	0.0	0.0	0.0
49	35.0	35.0	0.0	0.0	0.0	0.0	0.0
50	35.0	35.0	0.0	0.0	0.0	0.0	0.0

(To be fastened together with other answers to paper)

Index Number

Name

CROSS SECTION OF HOI-KOOK FA IN SANIANG
R.D. 36 + 0



155

0. EL = 9592 + MH 94

9592

9592 9 81 00 53 00 87

9592 C 1.50 0.30 1.50 0.30 87

9592 C 1.50 0.30 1.50 0.30 87

9592 C 1.50 0.30 1.50 0.30 87

9592 C 1.50 0.30 1.50 0.30 87

9592 C 1.50 0.30 1.50 0.30 87

9592 C 1.50 0.30 1.50 0.30 87

9592 C 1.50 0.30 1.50 0.30 87

9592 C 1.50 0.30 1.50 0.30 87

9592 C 1.50 0.30 1.50 0.30 87

9592 C 1.50 0.30 1.50 0.30 87

9592 C 1.50 0.30 1.50 0.30 87

9592 C 1.50 0.30 1.50 0.30 87

9592 C 1.50 0.30 1.50 0.30 87

9592 C 1.50 0.30 1.50 0.30 87

9592 C 1.50 0.30 1.50 0.30 87

9592 C 1.50 0.30 1.50 0.30 87

9592 C 1.50 0.30 1.50 0.30 87

9592 C 1.50 0.30 1.50 0.30 87

9592 C 1.50 0.30 1.50 0.30 87

9592 C 1.50 0.30 1.50 0.30 87

9592 C 1.50 0.30 1.50 0.30 87

9592 C 1.50 0.30 1.50 0.30 87

9592 C 1.50 0.30 1.50 0.30 87

9592 C 1.50 0.30 1.50 0.30 87

9592 C 1.50 0.30 1.50 0.30 87

9592 C 1.50 0.30 1.50 0.30 87

9592 C 1.50 0.30 1.50 0.30 87

9592 C 1.50 0.30 1.50 0.30 87

9592 C 1.50 0.30 1.50 0.30 87

9592 C 1.50 0.30 1.50 0.30 87

9592 C 1.50 0.30 1.50 0.30 87

9592 C 1.50 0.30 1.50 0.30 87

9592 C 1.50 0.30 1.50 0.30 87

9592 C 1.50 0.30 1.50 0.30 87

9592 C 1.50 0.30 1.50 0.30 87

9592 C 1.50 0.30 1.50 0.30 87

ROAD
SIDE
MIN
DRAIN
DRAIN
FENCE
DRAIN

X SECTION OF LIFTING POKER AT SHIPYARD
NO 351 D

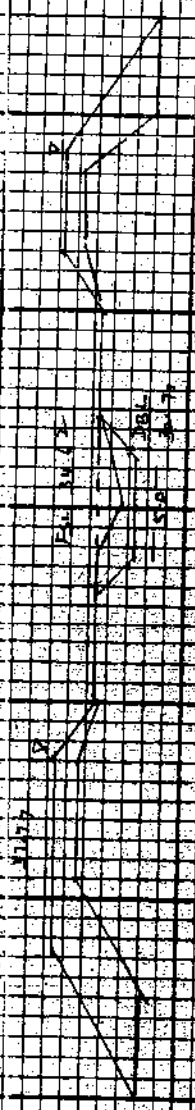

$$49.22 + 28.88 = 78.10$$

$$\frac{50.87}{5} = 10.174$$

1. 10.174 x 2 = 20.348
 2. 20.348 x 2 = 40.696
 3. 40.696 x 2 = 81.392
 4. 81.392 x 2 = 162.784
 5. 162.784 x 2 = 325.568

6. 325.568 x 2 = 651.136
 7. 651.136 x 2 = 1302.272
 8. 1302.272 x 2 = 2604.544
 9. 2604.544 x 2 = 5209.088
 10. 5209.088 x 2 = 10418.176

11. 10418.176 x 2 = 20836.352
 12. 20836.352 x 2 = 41672.704
 13. 41672.704 x 2 = 83345.408
 14. 83345.408 x 2 = 166690.816
 15. 166690.816 x 2 = 333381.632

16. 333381.632 x 2 = 666763.264
 17. 666763.264 x 2 = 1333526.528
 18. 1333526.528 x 2 = 2667053.056
 19. 2667053.056 x 2 = 5334106.112
 20. 5334106.112 x 2 = 10668212.224

21. 10668212.224 x 2 = 21336424.448
 22. 21336424.448 x 2 = 42672848.896
 23. 42672848.896 x 2 = 85345697.792
 24. 85345697.792 x 2 = 170691395.584
 25. 170691395.584 x 2 = 341382791.168

26. 341382791.168 x 2 = 682765582.336
 27. 682765582.336 x 2 = 1365531164.672
 28. 1365531164.672 x 2 = 2731062329.344
 29. 2731062329.344 x 2 = 5462124658.688
 30. 5462124658.688 x 2 = 10924249317.376

31. 10924249317.376 x 2 = 21848498634.752
 32. 21848498634.752 x 2 = 43696997269.504
 33. 43696997269.504 x 2 = 87393994539.008
 34. 87393994539.008 x 2 = 174787989078.016
 35. 174787989078.016 x 2 = 349575978156.032

DEPTH

PICTURE

BASE

YOUNG

DEPTH

DEPTH

DEPTH

DEPTH

**FORM OF BID
AND
APPENDICES TO BID**

FORM OF BID

Bid Reference No. _____
 (Name of Contract/Work)

To: _____

1. Having examined the bidding documents including Instructions to Bidders, Bidding Data, and Conditions of Contract, Specifications, Drawings and Bill of Quantities and Addenda Nos. _____ for the execution of the above-named work, we/I, the undersigned, offer to execute and complete the work and remedy any defects therein in conformity with the Conditions of Contract, Specifications, Drawings, Bill of Quantities and Addenda for the sum of Rs. _____ (Rupees _____) or such other sum as may be ascertained in accordance with the said conditions.
 2. We/I understand that all the Appendices attached hereto form part of this bid.
 3. As security for due performance of the undertakings and obligations of this bid, we/I submit herewith a bid security in the amount of Rupees _____ (Rs. _____) drawn in your favour or made payable to procuring agency and valid for a period of _____ days beginning from the date, bid is opened.
 4. We/I undertake, if our bid is accepted, to commence the works and to complete the whole of the works comprised in the contract within the time stated in Appendix-A to Bid.
 5. We/I agree to abide by this bid for the period of _____ days from the date fixed for opening the same and it shall remain binding upon us and may be accepted at any time before the expiration of that period.
 6. Unless and until a formal Agreement is prepared and executed, this bid, together with your written acceptance thereof, shall constitute a binding contract between us.
 7. We do hereby declare that the bid is made without any collusion, comparison of figures or arrangement with any other bidder for the works.
- We understand that you are not bound to accept the lowest or any bid you may receive.
9. We undertake, if our/my bid is accepted, to execute the Performance Security referred to in Clause 10 of Conditions of Contract for the due performance of the Contract.
 10. We confirm, if our bid is accepted, that all partners of the joint venture shall be liable jointly and severally for the execution of the Contract and the composition or the constitution

of the joint venture shall not be altered without the prior consent of the procuring agency.
(Please delete this in case of Bid form a single bidder)

in the capacity of _____ duly authorized to sign Bids for and on behalf of

Dated this _____ day of _____ 20____

Signature: _____

(Name of Bidder in Block Capitals)
(Seal)

Address: _____

Witness:

Signature: _____
Name: _____

Address: _____

Occupation: _____

SPECIAL STIPULATIONS

Clause

Conditions of Contract

1.	Engineer representing Consulting Firm hired by the procuring agency to issue variation in case of emergency.	3.1	Up to 2% of the contract price stated in the Letter of Acceptance.
2.	Amount of Performance Security	4.2	Up to 10% of contract price. Total amount including performance security and retention money deducted from bills should not exceed 10% of contract price stated in the Letter of Acceptance.
3.	Time for Furnishing Programme	8.3	Within 42 days from the date of receipt of Letter of Acceptance.
4.	Minimum amount of Third Party Insurance	18.3	Rs. _____ per occurrence with number of occurrences unlimited.
5.	Time for Commencement	8.1	Within 14 days from the date of receipt of Engineer's Notice to Commence, this shall be issued within fourteen (14) days after signing of Contract Agreement.
6.	Time for Completion (works & sections)	8.2 & 10.2	_____ days from the date of receipt of Engineer's Notice to Commence.
7.	Amount of Liquidity Damages/Delay Damages/Penalties	8.7	-----Damages per day (are to be mentioned) but total amount will not be more than 10% of contract Price.
8.	Defects Liability Period	11.1	_____ days from the effective date of Taking Over Certificate.
9.	Percentage of Retention Money	14.2	10 % of the amount of Interim/Running Payment Certificate.
10.	Limit of Retention Money	14.2	5 % of Contract Price stated in the Letter of Acceptance.
11.	Minimum amount of Interim/Running Payment Certificates	14.2	Rs. _____
12.	Time of Payment from delivery of Engineer's Interim/Running Payment Certificate to the procuring agency.	14.7	30 days in case of local currency or 42 days in case of foreign funded projects.
13.	Mobilization Advance.	14.2	10% of Contract Price stated in the Letter of Acceptance.

FOREIGN CURRENCY REQUIREMENTS

1. The bidder may indicate herein below his requirements of foreign currency (if any), with reference to various inputs to the works.
2. Foreign Currency Requirement as percentage of the bid price excluding Provisional Sums _____%.
3. Table of Exchange Rates

Unit of Currency	Equivalent in Pak. Rupees
Australian Dollar	-----
Euro	-----
Japanese Yen	-----
U.K. Pound	-----
U.S. Dollars	-----
-----	-----
-----	-----

**PRICE ADJUSTMENT UNDER CLAUSE 70/13.8
OF CONDITIONS OF CONTRACT**

A. Weight ages or coefficients are used for price adjustment.

The source of indices and the weight ages or coefficients for use in the adjustment formula under Clause 13.8 shall be as follows:

(To be filled by the procuring agency)

Cost Element	Description	Weight ages	Applicable index
1	2	3	4
(i)	Fixed Portion	0.350	
(ii)	Local Labor		Government of Pakistan (GoP) Federal Bureau of Statistics (FBS) Monthly Statistical Bulletin.
(iii)	Cement - in bags		" " "
(iv)	Reinforcing Steel		" " "
(v)	High Speed Diesel (HSD)		" " "
(vi)	Bricks		" " "
(vii)	Bitumen		" " "
(viii)			
	Total	1.000	

Notes:

- 1) Indices for "(ii)" to "(vii)" are taken from the Government of Pakistan Federal Bureau of Statistics, Monthly Statistical Bulletin. The base cost indices or prices shall be those applying 15 days prior to the latest day for submission of bids. Current indices or prices shall be those applying 28 days prior to the last day of the billing period.
- 2) Any fluctuation in the indices or prices of materials other than those given above shall not be subject to adjustment of the Contract Price.
- 3) Fixed portion shown here is for typical road project, procuring agency to determine the weight age of Fixed Portion considering only those cost elements having cost impact of seven (7) percent or more on his specific project.

- B** **When Escalation is allowed on the materials only.**
 Price adjustment on following items shall be allowed:

Cost Element	Description	Base price	Applicable index
1	2	3	4
(i)	Cement - in bags		Government of Pakistan (GoP) Federal Bureau of Statistics (FBS) Monthly Statistical Bulletin.
(ii)	Reinforcing Steel		" " "
(iii)	Bricks		" " "
(iv)	Bitumen		" " "
(v)	Wood (Composite item)		" " "
	Total five items.		

BILL OF QUANTITIES (SAMPLE)**B. Work Items. (Road /PHE Work)***

1. The Bill of Quantities contains the following Bills and Items:

Bill No. 1	-	Earthworks
Bill No. 2	-	Hard Crust and Surface Treatment
Bill No. 3	-	Culverts and Bridges
Bill No. 4	-	Subsurface Drains, Pipe Laying and Man holes
Bill No. 5	-	Tube wells, Pump houses and Compound wall
Bill No. 6	-	Miscellaneous Items

Day work Schedule
Summary Bill of Quantities

2. Bidders shall price the Bill of Quantities in Pakistani Rupees only.

**Procuring Agency can add and delete the Items as per its requirement.*

BILL OF QUANTITIES (SAMPLE)

Bill No. 1 Earthworks/Plinth and Foundation

Item	Description	Unit	Quantity	Rate		Amount Rupees
				Rupees figures	Rupees in words	
1	2	3	4	5		6
101						
102						
103						
104						
105						
106						
Total for Bill No. 1 (Carried forward to Summary Page)						

BILL OF QUANTITIES (SAMPLE)

Bill No. 2 Hard Crust and Surface Treatment /Ground Floor.

Item	Description	Unit	Quantity	Rate		Amount Rupees
				Rupees figures	Rupees in words	
1	2	3	4	5		6
201						
202						
203						
204						
205						
206						
Total for Bill No. 2 (Carried forward to Summary Page)						

BILL OF QUANTITIES (SAMPLE)

Bill No. 3 Culverts and Bridges/First and Subsequent Floors

Item	Description	Unit	Quantity	Rate		Amount
				Rupees in figures	Rupees in words	Rupees
1	2	3	4	5		6
301						
302						
303						
304						
305						
306						
Total for Bill No. 3 (Carried forward to Summary Page)						

BILL OF QUANTITIES (SAMPLE)

Bill No. 4 Subsurface Drains/ Pipe Laying and Man holes/Internal water Supply and Sanitary Fittings

Item	Description	Unit	Quantity	Rate		Amount Rupees
				Rupees in figures	Rupees in words	
1	2	3	4	5		6
401						
402						
403						
404						
205						
406						
Total for Bill No. 4						
(Carried forward to Summary Page)						

BILL OF QUANTITIES (SAMPLE)

Bill No. 5 Tube wells and Pump-houses/Internal Electrification

Item	Description	Unit	Quantity	Rate		Amount
				Rupees in figures	Rupees in words	Rupees
1	2	3	4	5		6
501						
502						
503						
504						
505						
506						
Total for Bill No. 5						
(Carried forward to Summary Page)						

Schedul "B"

NAME OF WORK PROVIDING STONE PITCHING ALONG PFL
RD 152 TO 160 NIP SIDE AND 161 TO 163 NIP SIDE.

Quantity	item	Rate	Per	Amount
280634 Cft.	1. Excavation in foundtaion of buildings bridges and other structure i/c dag-belling dressing, refilling around structure with excavated earth watering and ramming lead upto one chain and lift upto 5 feet. (b) Ordinary Soil. [S.Item No.18(b) P.No.04]	3176.25	%o Cft.	891,363.74
77867 Cft.	2. Extra for slush or daldal i/c dewatering [S.Item No.16. P.No.04]	2420.00	%o Cft.	188,438.14
6337.59 Cft.	3. Cement concrete plain i/c placing, comp- acting, finishing and curing complete (i/c screening and washing of stone aggregate without shuttering). (f) Ratio 1:3:6	12595.00	% Cft	798,219.46
6173.50 Cft.	(h) Ratio 12:4 [S.Item No.5(f)(h) P.No.18]	14429.25	% Cft	890,789.75
2079.72 Cft.	4. FOUNDATION AND PLINTH Coursed Rubble masonry i/c hammer dressing (d) In cement sand mortar (iii) Ratio 1:6 [S.Item No.2(d)(iii), P.No.32]	25321.00	% Cft	526,605.90
15302.32 Cft.	5. SUPER STRUCTURE. Coursed Rubble masonry hammer dressED. (d) In cement sand mortar (iii) Ratio 1:6 [S.Item No.4(d)(iii), P.No.33]	26288.46	% Cft	4,154,186.57
110880 Cft.	6. Stone filling dry hand packed as filling behind walls or in pitching and apron. [S.Item No.6, P.No.34]	2684.00	% Cft	2,976,019.20
173128 Sft	7. Formation dressing and preparing sub-grade (a) slope [S.Item No.6(a) P.No.34]	453.75	% Sft	785,568.30
				11,211,191.07

Quantity	Item	Rate	Per	Amount
				11,211,191.07
278173 Cft.	8. Stone Pitching i/c sub-base with hammer dressed stone on surface laid in courses i/c carriage of material within 3 chains [S.Item No.23 P.No.35]	5377.63	% Cft	14,959,114.69
1728 Sft.	9. Erection and removal of centering for RCC or plain cement concrete works of deodar wood (2nd class). (a) (i) Horizontal [S.Item No.18(a)(i) P.No.21]	7693.13	% Sft	132,937.29
775914 Cft.	10. Borrowpit excavation undressed lead Upto 100 ft (a) Ordinary soil. (a) Ordinary Soil. [S.Item No.3(a) P.No.1]	2117.50	%o Cft.	1,642,997.90
775914 Cft.	11. Carriage of 100 Cft/5 ton of all material like stone aggregate, spawal, coal lime surkhi etc. B.G.Rail fastening joints and crossing bridges girders pipe sheet rail MS bars etc or 1000 Nos bricks 10"x3"x3" or 1000 Nos tiles 12"x6"x2" or 150 cft timber or 1000 Nos maund or fuel wood by trolley or any other means owned by contractors 3 Miles [S.Item No.1, P.No.1 Sch. Carriage]	407.00	% Cft	3,157,969.97
775914 Cft.	12. Dressing and levelling of earth work to designed section etc complete. (b) Ordinary or hard soil. [S.Item No.11(b), P.No.3]	187.55	% Cft	145,522.67
512 Days	13. Full hire charges of Pumping set per day inclusive wages of driver and assistant, fuel or electric energy plate form required for placing pump at in lower depth with suction and delivery pipes for pumping out water i/c erection and dismantling after completion of the job [S.Item No.23(iv), P.No.53 PHEW Vol:III]	1000.00	P.Day	512,000.00

 31,761,733.58

Quantity	item	Rate	Per	Amount
				31,761,733.58
2043 Hours	14. For pumping set about 10 HP but not less 5 HP (Beyond 8 hours) [S.Item No.24(iv), P.No.53 PHEW Vol:III]	188.00	P.Hour	384,084.00
	Total Rs.			32,145,817.58

Part B Dumping of Stone

Quantity	item	Rate	Per	Amount
62400.00 Cft.	1. Supply stone boulders 9" and above. [S.Item No.60 P.No.04 Sch: of Material]	1400.00	% Cft.	873,600.00
62400.00 Cft.	2. Supply within 5 chains (a) Boulders 9" and above. [S.Item No.10(a) P.No.81]	1095.00	% Cft.	683,280.00
62400.00 Cft.	3. Dumping shingle, spawls and boulders i/c carriage material within 3 chains. [S.Item No.17 P.No.81]	529.38	% Cft.	330,333.12
				<u>1,887,213.12</u>
	A=			32,145,817.58
	B=			<u>1,887,213.12</u>
	G. Total.			<u>34,033,030.70</u>

NB: No above perium is allowed on item No. 11 of Sch: A.

Contractor

Executive Engineer
Upper Pinyari Division
Hyderabad

BILL OF QUANTITIES (SAMPLE)

Bill No. 6 - Miscellaneous Items

Item	Description	Unit	Quantity	Rate		Amount Rupees
				Rupees in figures	Rupees in words	
1	2	3	4	5		6
601	Mobilization Cost					
602						
603						
604						
605						
606						
Total for Bill No. 6 Carried forward to Summary Page)						

BILL OF QUANTITIES (SAMPLE)

Bill No. 7		External Development				
Item	Description	Unit	Quantity	Rate		Amount
				Rupees in figures	Rupees in words	
1	2	3	4	5		6
601	Items of water supply & drainage					
602	Paths & parks					
603	External electrification					
604						
605						
606						
Total for Bill No. 7						
Carried forward to Summary Page)						

BILL OF QUANTITIES

C. Day work Schedule

General

1. Reference is made to Sub-Clause 13.6 of the General Conditions of Contract. Work shall not be executed on a day work basis except by written order of the Engineer. Bidders shall enter basic rates for day work items in the Schedules, which rates shall apply to any quantity of day work ordered by the Engineer. Nominal quantities have been indicated against each item of day work, and the extended total for day work shall be carried forward to the bid price.

Day work Labour

2. In calculating payments due to the contractor for the execution of day work, the actual time of classes of labour directly doing the day work ordered by the Engineer and for which they are competent to perform will be measured excluding meal breaks and rest periods. The time of gangers (charge hands) actually doing work with the gang will also be measured but not the time of foreman or other supervisory personnel.
3. The contractor shall be entitled to payment in respect of the total time that labour is employed on day work, calculated at the basic rates entered by him in the Schedule of day work Rates for labour together with an additional percentage, payment on basic rates representing the contractor's profit, overheads, etc., as described below:
 - a) the basic rates for labour shall cover all direct costs to the contractor, including (but not limited to) the amount of wages paid to such labour, transportation time, overtime, subsistence allowances and any sums paid to or on behalf of such labour for social benefits in accordance with Pakistan law. The basic rates will be payable in local currency only; and
 - b) the additional percentage payment to be quoted by the bidder and applied to costs incurred under (a) above shall be deemed to cover the contractor's profit, overheads, superintendence, liabilities and insurances and allowances to labour timekeeping and clerical and office work; the use of consumable stores, water, lighting and power; the use and repair of staging's, scaffolding, workshops and stores, portable power tools, manual plant and tools; supervision by the contractor's staff, foremen and other supervisory personnel; and charges incidental to the foregoing.

SCHEDULE OF DAYWORK RATES

I. Labour

Item No.	Description	Unit	Nominal Quantity	Rate (Rs) in Figure	Rate (Rs) in Words	Extended Amount (Rs.)
1	2	3	4	5	6	7
D101	Ganger	Hr	500			
D102	Labourer	Hr	5,000			
D103	Brick layer	Hr	500			
D104	Mason	Hr	500			
D105	Carpenter	Hr	500			
D106	Steel work Erector	Hr	500			
	-----etc-----	Hr	500			
D113	Driver for vehicle up to 10 tons	Hr	1,000			
D114	Operator for excavator, dragline, shovel or crane	Hr	500			
D115	Operator for tractor, (tracked) with dozer blade or ripper	Hr	500			
E 122	Sub Total					
	Allow _____ percent of subtotal for Contractor's overhead, profit, etc, in accordance with Paragraph 3(b) of Day work Schedule					
	Total for Day work: Labour : _____					
	(Carried forward to Day work Summary)					

Appendix-D to Bid

Day work Material

4. The contractor shall be entitled to payment in respect of materials used for day work (except for materials for which the cost is included in the percentage addition to labour costs as detailed heretofore), at the basic rates entered by him in the Schedule of Day work Rates for materials together with an additional percentage payment on the basic rates to cover overhead charges and profit, as follows:
 - a) the basic rates for materials shall be calculated on the basis of the invoiced price, freight, insurance, handling expenses, damage, losses, etc., and shall provide for delivery to store for stockpiling at the site. The basic rates shall be stated in local currency but payment will be made in the currency or currencies expended upon presentation of supporting documentation;
 - b) the additional percentage payment shall be quoted by the bidder and applied to the equivalent local currency payments made under Sub-Para(a) above; and
 - c) the cost of hauling materials used on work ordered to be carried out as Day work from the store or stockpile on the site to the place where it is to be used will be paid in accordance with the terms for Labour and Constructional Plant in this Schedule.

SCHEDULE OF DAYWORK RATES

II. Materials

Item No.	Description	Unit	Nominal Quantity	Rate (Rs) in Figure	Rate (Rs) in Words	Extended Amount (Rs.)	
1	2	3	4	5	6	7	
D201	Cement, ordinary Portland or equivalent in bags	M: Ton	200				
D202	Mild Steel reinforcing bar up to 16mm diameter to BS 4449 or equivalent	M: Ton	100				
D203	Fine aggregate for concrete as specified in Clause _____	Cu: M	1,000				
D204	-----etc-----						
D222	Gelignite (Noble Special Gelatine 60 % or equivalent) including caps, fuse, wire and requisite accessories	M: Ton	10				
D223	Sub Total						
	Allow _____ percent of subtotal for Contractor's overhead, profit, etc., in accordance with Paragraph 4(b) of Day work Schedule						
	Total for Day work: Materials _____						
	(Carried forward to Day work Summary) _____						

Appendix-D to Bid

Day Work Constructional Plant

5. The contractor shall be entitled to payments in respect of constructional plant already on site and employed on Day work at the basic rental rates entered by him in the Schedule of Day work Rates for constructional plant. The said rates shall be deemed to include complete allowance for depreciation, interest, indemnity and insurance, repairs, maintenance, supplies, fuel, lubricants, and other consumables, and all overhead, profit and administrative costs related to the use of such equipment. The cost of drivers, operators and assistants will be paid for separately as described under the section on Day work Labour.
6. In calculating the payment due to the Contractor for constructional plant employed on Day work, only the actual number of working hours will be eligible for payment, except that where applicable and agreed with the Engineer, the travelling time from the part of the site where the constructional plant was located when ordered by the Engineer to be employed on Day work and the time for return journey thereto shall be included for payment.
7. The basic rental rates for constructional plant employed on Day work shall be stated in Pakistani Rupees.

SCHEDULE OF DAYWORK RATES

III. Constructional Plant

Item No.	Description	Unit	Nominal Quantity	Rate (Rs.) in Figure	Rate Rs.) in Words	Extended Amount (Rs.)
1	2	3	4		5	6
D301	Excavator ,face shovel or dragline:					
	1. Up-to and including 1 Cu.M.	Hr	500			
	2. Over 1 Cu.M to 2 Cu. M.	Hr	400			
	3. Over 2 Cu. M	Hr	100			
D302	Tractor (tracked) including bull or angle dozer:					
	1. Up-to and including 150 HP	Hr	500			
	2. Over 150 to 200 HP	Hr	400			
	3. Over 200 to 250 HP	Hr	200			
D303	Tractor with ripper:					
	1. Up-to and including 200 HP	Hr	400			
	2. Over 200 to 250 HP	Hr	200			
D304	-----etc-----					
Total for day work: Constructional Plant _____ (Carried forward to day work summary)						

DAYWORK**Summary (Day work)**

	Amount (Rs.)
(I) Total for day work: Labour	_____
(II) Total for day work: Materials	_____
(III) Total for day work: Constructional Plant	_____
<hr/>	
Total for day work (Carried forward to summary page of Bill of Quantities)	_____

BILL OF QUANTITIES (SAMPLE)**SUMMARY**

	■ Amount (Rs.)
Bill No. 1: Earthworks/Plinth and Foundation	
Bill No. 2: Culverts and Bridges/Ground Floor	
Bill No. 3: Subsurface Drains/Internal Water Supply & Sanitary Fittings	
Bill No. 4: Subsurface Drains/ Pipe Laying and Man holes/Internal water Supply and Sanitary Fittings	
Bill No. 5: Tube wells and Pump-houses/Internal Electrification	
Bill No. 6: Miscellaneous Items	
Bill No. 7: External Development	
Sub-Total of Bills	_____
Day work	_____
Bid Price	_____

Note: All Provisional Sums are to be expended in whole or, in part at the direction and discretion of the Engineer in accordance with Sub-Clauses 52.4 and 58.2 of the General Conditions of Contract Part- I.

Appendix-E to Bid

PROPOSED CONSTRUCTION SCHEDULE

Pursuant to Sub-Clause 43.1 of the General Conditions of Contract, the works shall be completed on or before the date stated in Appendix-A to Bid. The bidder shall provide as Appendix-E to Bid, the Construction Schedule in the bar chart (CPM, PERT or any other to be specified herein) showing the sequence of work items and the period of time during which he proposes to complete each work item in such a manner that his proposed programme for completion of the whole of the works and parts of the works may meet procuring agency's completion targets in days noted below and counted from the date of receipt of Engineer's Notice to Commence (Attach sheets as required for the specified form of Construction Schedule):

<u>Description</u>	<u>Time for Completion</u>
1) Whole works	_____ days
2) Part-A	_____ days
3) Part-B	_____ days
4) _____	_____ days
5) _____	_____ days

METHOD OF PERFORMING THE WORK

The bidder is required to submit a narrative outlining the method of performing the work. The narrative should indicate in detail and include but not be limited to:

1. Organization Chart indicating head office and field office personnel involved in management and supervision, engineering, equipment maintenance and purchasing.
2. Mobilization in Pakistan, the type of facilities including personnel accommodation, office accommodation, provision for maintenance and for storage, communications, security and other services to be used.
3. The method of executing the works, the procedures for installation of equipment and machinery and transportation of equipment and materials to the site.

LIST OF MAJOR EQUIPMENT – RELATED ITEMS

[The bidder will provide on Sheet 2 of this Appendix a list of all major equipment and related items, under separate heading for items owned, to be purchased or to be arranged on lease by him to carry out the works. The information shall include make, type, capacity, and anticipated period of utilization for all equipment which shall be in sufficient detail to demonstrate fully that the equipment will meet all requirements of the Specifications.]

LIST OF MAJOR EQUIPMENT (SAMPLE)

Owned Purchased or Leased	Description of Unit (Make, Model, Year)	Capacity HP Rating	Condition	Present Location or Source	Date of Delivery at Site	Period of Work on Project
1	2	3	4	5	6	7
a. Owned						
b. To be Purchased						
c. To be arranged on Lease						

CONSTRUCTION CAMP AND HOUSING FACILITIES

The Contractor in accordance with Clause 6 of the Conditions of Contract shall provide description of his construction camp's facilities and staff housing requirements.

The contractor shall be responsible for pumps, electrical power, water and electrical distribution systems, and sewerage system including all fittings, pipes and other items necessary for servicing the contractor's construction camp.

The bidder shall list or explain his plans for providing these facilities for the service of the contract as follows:

1. Site Preparation (clearing, land preparation, etc.).
2. Provision of Services.
 - a) Power (expected power load, etc.).
 - b) Water (required amount and system proposed).
 - c) Sanitation (sewage disposal system, etc.).
3. Construction of Facilities
 - a) Contractor's Office, Workshop and Work Areas (areas required and proposed layout, type of construction of buildings, etc.).
 - b) Warehouses and Storage Areas (area required, type of construction and layout).
 - c) Housing and Staff Facilities (Plans for housing for proposed staff, layout, type of construction, etc.).
4. Construction Equipment Assembly and Preparation (detailed plans for carrying out this activity).
5. Other Items Proposed (Security services, etc.).

LIST OF SUBCONTRACTORS

I/We intend to subcontract the following parts of the work to subcontractors. In my/our opinion, the subcontractors named hereunder are reliable and competent to perform that part of the work for which each is listed.

Enclosed are documentation outlining experience of subcontractors, the curriculum vitae and experience of their key personnel who will be assigned to the contract, equipment to be supplied by them, size, location and type of contracts carried out in the past.

Part of Works (Give Details)	Subcontractor (With Complete Address)
1	2

Appendix-J to Bid

ESTIMATED PROGRESS PAYMENTS (SAMPLE)

Bidder's estimate of the value of work which would be executed by him during each of the periods stated below, based on his Programme of the works and the Rates in the Bill of Quantities, expressed in Pakistani Rupees:

Quarter/ Year/ Period	Amounts (in thousands)
1	2
1st Quarter	
2 nd Quarter	
3 rd Quarter	
4 th Quarter	
5 th Quarter	
6 th Quarter	
7 th Quarter	
8 th Quarter	
9 th Quarter	
Bid Price	

**ORGANIZATION CHART
FOR THE
SUPERVISORY STAFF AND LABOUR**

(To be filled in by the bidder)

SPECIFICATIONS

DRAWINGS

SECTION OF STONE PITCHING, PROFILE AND C/FORT ALONG P.F.I

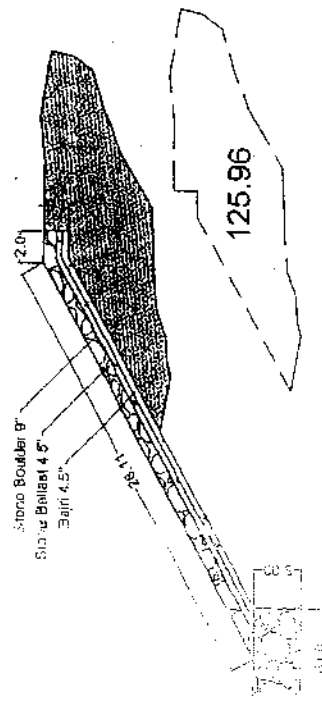

Stone Pitching

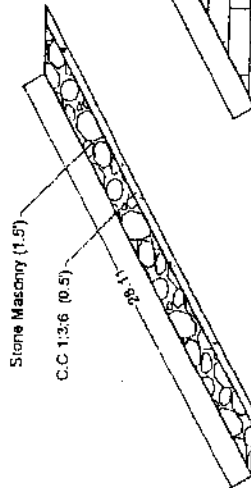

Profile

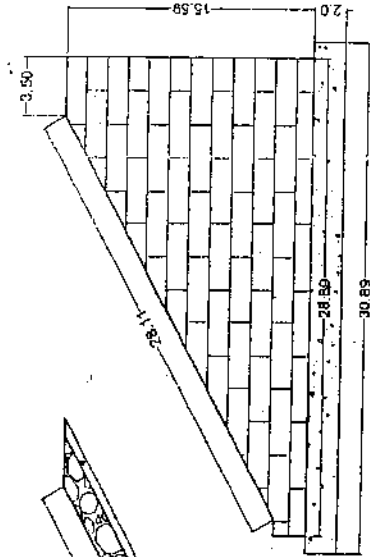

C/Fort

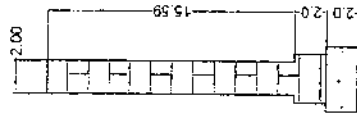

C/Fort

SUB ENGINEER

ASSISTANT EXECUTIVE ENGINEER
DARRO SUB DIVISION

[Signature]
EXECUTIVE ENGINEER
UPPER PRIMARY DIVISION
HYDERABAD

SCHEDULE OF PRICES

Item No.	Description	Quantity	Unit Rate(Rs)	Total Amount (Rs)
1.	I. (Civil works)			
2.				
3.				
1.	II. Internal sanitary and water supply.			
2.				
3.				
1.	III. Electrification.			
2.				
3.				
1.	IV. External Development works.			
2.				
3.				
1.	V. Miscellaneous Items			
2.				
3.				
<p>Total (to be carried to Summary of Bid Price) Add/ Deduct the percentage quoted above/below on the prices of items based on Composite Schedule of Rates.</p>				

Schedule "B"

NAME OF WORK EARTH WORK AND PROVIDING STONE PITCHING AND STONE PROTECTION WALL ALONG RAJ WAH EX: PFL RD. 0 TO 30, STONE PITCHING AND PROTECTION WALL, PUMPING SCHEME.

Quantity	item	Rate	Per	Amount
1620000 Sft.	1. Jungle clearance and removing within 100 ft. (a) Light. [S.Item No.4(a), P.No.95]	75.63	%o Sft.	122,520.60
37.19 Acres.	2. Ploughing 3 times [S.Item No.41. P.No.103]	1769.63	P.Acre	65,812.54
3804300 Cft.	3. Borrowpit excavation undressed lead Upto 100 ft. (a) Ordinary soil. [S.Item No.3(a), P.No.01]	2117.50	%o Cft	8,055,605.25
1902150 Cft.	4. Carriage of 100 Cft/5 ton of all material like stone aggregate, spawal, coal lime surkhi etc. B.G.Rail fastening joints and crossing bridges girders pipe sheet rail MS bars etc or 1000 Nos bricks 10"x3"x3" or 1000 Nos tiles 12"x6"x2" or 150 cft timber or 1000 Nos maund or fuel wood by trolley or any other means owned by contractors 1 Mile [S.Item No.1, P.No.01 Sch: of Carriage]	407.00	% Cft	7,741,750.50
1902150 Cft.	5. Extra for every 50' additional lead or Part thereof 6 leads. (a) For earth work (Soft,ordinary hard and very hard 6x100.78) [S.Item No.8(a) P.No.2]	604.68	%o Cft	1,150,192.06
3804300 Cft.	6. Dressing and levelling of earth work to designed section etc complete. (b) Ordinary or hard soil. [S.Item No.11(b), P.No.3]	187.55	%o Cft	713,496.47
	Total Rs.			<u>17,849,377.42</u>

Part C

Quantity	Item	Rate	Unite	Amount
3	1. Suplying and fixing Electric Motor 100 HP siminis or equilable coupled with pump 12/12, foundation etc complete. Item 97(i) P. 110	7,450,000	Each	22,350,000.0
3	2. Suplying and fixing Pennal board 150 Amp ioncluding magnatic condicer volt meeter Am meter etc complete. sch (material) Elect: P. 9	10,000	Each	30,000.0
180	3. Suplying and fixing LT Cable 70 mm three core made Pakistan Cble or equivalent from Motor to Pennel Board. sch (material) Elect: P. 10	3,558	P.Meter	640,440.0
40	4. Suplying and fixing LT Cable 120mm three core Paksitan Cable from Pennel board to Transformer. sch (material) Elect: P. 10	6,349	P.Meter	253,960.0
70	5. HT Cable three core 70 mm from trasformor to main line, sch (material) Elect: P. 10	3,558	P.Meter	249,060.0
300	6. M.S pipe 12" dia 4 mm thick. sch (material) P.H.E P. 23	2,750	P.Rft	825,000.0
60	7. M.S flangirs 12" dia 8 mm thick. sch (material) P.H.E P. 17	2,750	Each	165,000.0
2	8. MS foot value.	45,000	Each	90,000.0
100	9. M.S nut bolts. sch (material) P.H.E P. 26	250	P.KG	25,000.0

Quantity	Item	Rate	Unite	Amount
50	10. M.S washer. sch (material) P.H.E P. 26	120	P.KG	6,000.0
60	11. Rubber sheet 24" length. sch (material) P.H.E P. 26	220	P.KG	13,200.0
	12. 250 Amp from pannel bord to main pannel. sch (material) Elect: P. 9	22,800	Each	22,800.0
			Total.	<u>24,670,460.0</u>
		A=		17,849,377.42
		B=		1,733,319.22
		C=		<u>24,670,460.0</u>
		G. Total.		<u>44,253,156.64</u>

NB: No above premium is allowed to item No. 4 of part A and on all items of part C.

Contractor

Executive Engineer,
Upper Pinyari Division,
Hyderabad.

***DRAWINGS**

** (Note: The Engineer/Procuring Agency may incorporate specific Drawings for Bidding purposes only or may include the detailed drawings in a separate volume, if necessary).*

